



ClearSpan™ Solarguard™ Oversized Garages



Photo may show a different but similar model.

©2012 ClearSpan™
All Rights Reserved. Reproduction
is prohibited without permission.



WARNING: Cancer and Reproductive Toxicity - P65Warnings.ca.gov

STK#	DIMENSIONS
PB01400R4	20' W x 12' H x 24' L
PB01410R4	20' W x 12' H x 28' L
PB01420R4	20' W x 12' H x 36' L

Revision date: 08.16.12



YOU MUST READ THIS DOCUMENT BEFORE YOU BEGIN TO ASSEMBLE THE SHELTER.

Thank you for purchasing this ClearSpan™ shelter. When properly assembled and maintained, this product will provide years of reliable service. These instructions include helpful hints and important information needed to safely assemble and properly maintain the shelter. Please read these instructions **before** you begin.

If you have any questions during the assembly, contact Customer Service for assistance.

SAFETY PRECAUTIONS

- Wear eye protection.
- Wear head protection.
- Wear gloves when handling metal tubes.
- Use a portable GFCI (Ground Fault Circuit Interrupter) when working with power tools and cords.
- Do not climb on the shelter or framing during or after construction.
- Do not occupy the shelter during high winds, tornadoes, or hurricanes.
- Provide adequate ventilation if the structure is enclosed.
- Do not store hazardous materials in the shelter.
- Provide proper ingress and egress to prevent entrapment.

ANCHORING INSTRUCTIONS

Prior to assembling this shelter, please read the **MUST READ** document included with the shipment.

⚠ WARNING: The anchor assembly is an integral part of the shelter construction. Improper anchoring may cause shelter instability and failure of the structure. Failing to anchor the shelter properly *will void the manufacturer's warranty* and may cause serious injury and damage.

LOCATION

Choosing the proper location is an important step before you begin to assemble the structure.

The following suggestions and precautions will help you determine whether your selected location is the best location.

- Never erect the structure under power lines.
- Identify whether underground cables and pipes are present *before* preparing the site or anchoring the structure.
- Location should be away from structures that could cause snow to drift on or around the building.
- Do not position the shelter where large loads such as snow and ice, large tree branches, or other overhead obstacles could fall.

SITE

After choosing a location, proper preparation of the site is essential. Follow the information below.

- *A level site is required.* The site must be level to properly and safely erect and anchor the structure.
- For sites that are not concrete or gravel, placing wood blocks or other suitable supports under each rafter leg helps prevent the pipes from sinking or working into the site.
- Drainage: Water draining off the structure and from areas surrounding the site should drain away from the site to prevent damage to the site, the structure, and contents of the structure.

⚠ WARNING: The individuals assembling this structure are responsible for designing and furnishing all temporary bracing, shoring and support needed during the assembly process. For safety reasons, those who are not familiar with recognized construction methods and techniques must seek the help of a qualified contractor.

ASSEMBLY PROCEDURE

Following the instructions as presented will help ensure the proper assembly of your shelter. Failing to follow these steps may result in an improperly assembled and anchored shelter and will void all warranty and protection the owner is entitled.

The steps outlining the assembly process are as follows:

1. Verify that all parts are included in the shipment. Notify Customer Service for questions or concerns.
2. Read these instructions, the Must Read document, and all additional documentation included with the shipment **before** you begin assembling the shelter.
3. Gather the tools, bracing, ladders (and lifts), and assistance needed to assemble the shelter.
4. Check the weather **before** you install the roof cover and any panels (if equipped). Do not install covers or panels on a windy or stormy day.
5. Re-evaluate the location and site based on the information and precautions presented in the documentation included with the shipment.
6. Prepare the site (if applicable).
7. Assemble the frame components in the order they are presented in these instructions.
8. Assemble the frame including the struts (if equipped).
9. Consult the MUST READ document and properly anchor the assembled frame.
10. Install, tighten, and secure the end panel and main cover (if equipped). This applies to fabric covers that stretch over the frame assembly. Your shelter may include roof panels or side panels or both.
11. Read the Care and Maintenance information at the end of these instructions.

LIST OF WORDS AND PHRASES

Before you begin, it is important to become familiar with the words and phrases used in this instruction manual.

These words and phrases are common to most ClearSpan™ shelters and identify the different parts of the shelter. (Some are used in this document. Others may not apply to this particular shelter.) These terms describe the shipped parts and can also be found on the materials list/spec sheets included with the shipment. To aid in the assembly, read through the following definitions before you begin to assemble your shelter.

- **Conduit:** An assembly of pipes used to secure the main cover and end panels (if equipped). Purlins and some strut assemblies also consist of connected pipes to form a conduit. Each pipe joint of a conduit assembly is secured with a self-tapping Tek screw.
- **Coupler or Fitting:** A part of the frame assembly where legs, purlins and rafter pipes are inserted and secured. In most instances, 3-way and 4-way couplers are used. In some larger applications, couplers are used to secure the joints of the different rafter sections during the assembly of the rafters. Some shelters do not use couplers.
- **Foot or Rafter Foot:** The part attached to and found at the base of the rafter or leg of the shelter. Depending on the shelter, the foot is an optional purchase. Some shelters do not offer an optional foot. Some use 1-Way connectors.
- **Must Read Document:** This document includes building and shelter anchoring instructions, steps for end wall reinforcement, safety precautions, and notices and warnings. The Must Read document is sent with all shelters and buildings. If you did not receive a Must Read document, contact Customer Service to request one.
- **On-Center:** Term used to describe a measurement taken from the vertical center of the rafter or frame member to the vertical center of another.
- **Purlin:** The pipe assembly that runs perpendicular to the rafters or framework that supports the main cover. Purlins are found on the sides and roof areas of the assembled frame, are evenly spaced, and typically run from the front to the back of the shelter.
- **Plain or Straight Pipe:** A term used to describe a pipe that has the same diameter or width throughout its entire length.
- **Strut:** A strut is usually a length of pipe with two flattened ends and is used for diagonal bracing of the shelter frame. A strut is typically secured to the frame work by special brackets and bolts.
- **Swaged End or Swaged Pipe:** The term “swaged” refers to the tapered end of the pipe or tube. Swaged ends of a pipe can be inserted into couplers and the straight ends of other pipes.
- **Tek Screw:** A self-tapping fastener used to secure pipe joints and to fasten brackets to rafters.

CLEARSPAN™ GARAGES & STORAGE SHEDS

REQUIRED TOOLS

Space below is reserved for customer notes.

The following list identifies the main tools needed to assemble the shelter. Additional tools and supports may be needed depending on the structure, location, and application.

- Tape measure or measuring device
- Variable speed drill and impact driver (cordless with extra batteries works best)
- Wrench, ratchet and socket (recommended)
- Allen wrench set. (Fittings differ. Fitting set screws may be standard or metric.)
- Scissors
- Two ropes long enough to reach over the shelter
- Hammers and gloves
- Metal file and metal cutting saw
- Duct tape
- Box cutter or utility knife
- Ladders, work platforms, and other machinery for lifting designed to work safely at the height of the shelter

UNPACK AND IDENTIFY PARTS

The following steps will ensure that you have all the necessary parts before you begin to assemble the shelter.

1. Unpack the contents of the shipment and place where you can easily inventory the parts. Refer to the Bill of Materials/Spec Sheets.
2. Verify that all parts listed on the Bill of Materials/Spec Sheets are present. If anything is missing or you have questions, consult the Pictorial Parts Guide and all shelter diagrams for clarification, or contact Customer Service.

NOTE: At this time, you do not need to open the plastic bags containing smaller parts such as fasteners or washers.

QUICK START GUIDE

For a quick overview of this shelter and its components, consult the Quick Start Guide at the back of these instructions.

ClearSpan

The following graphics and photos will help you identify the different parts and show you how they are used. (Not all parts are shown.)

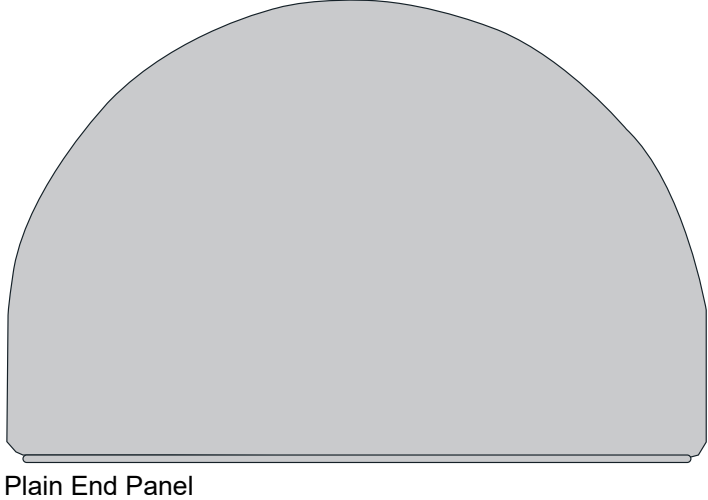
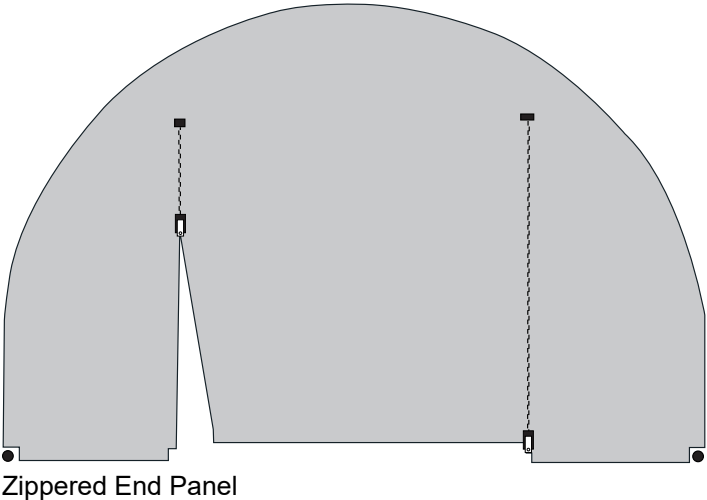
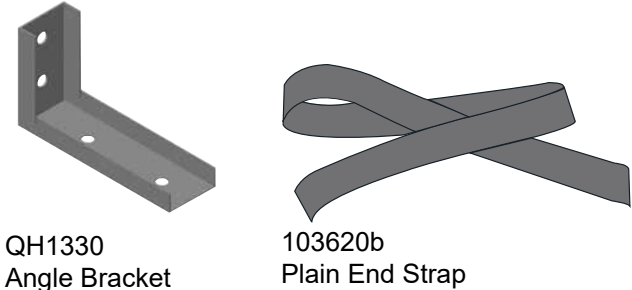
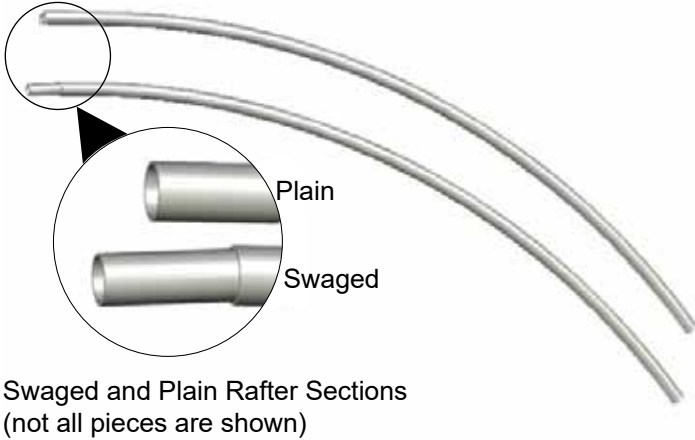
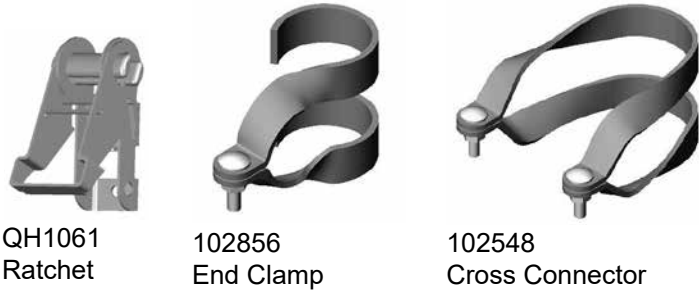
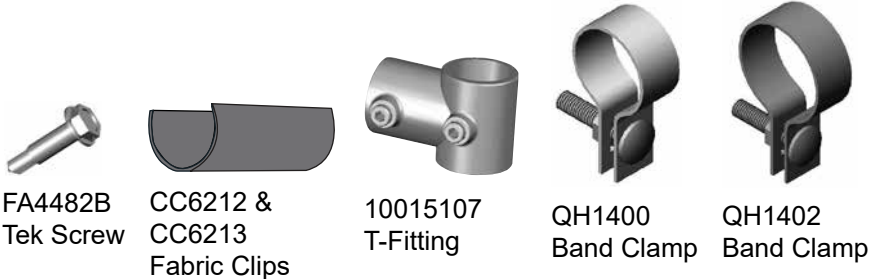



Round Style Oversized Garage

OVERVIEW

This section is an overview of the process for assembling your Round Style Oversized Garage. For details, please see section, Assembling the Round Style Oversized Garage Components. See illustration below to identify main parts of shelter.

1. Locate the required parts for each assembly procedure.
2. Assemble the rafters and frame, and square frame.
3. Prepare end panels and insert end conduits.
4. Connect end conduits and anchor the shelter.
5. Attach end panels and prepare and attach main cover.

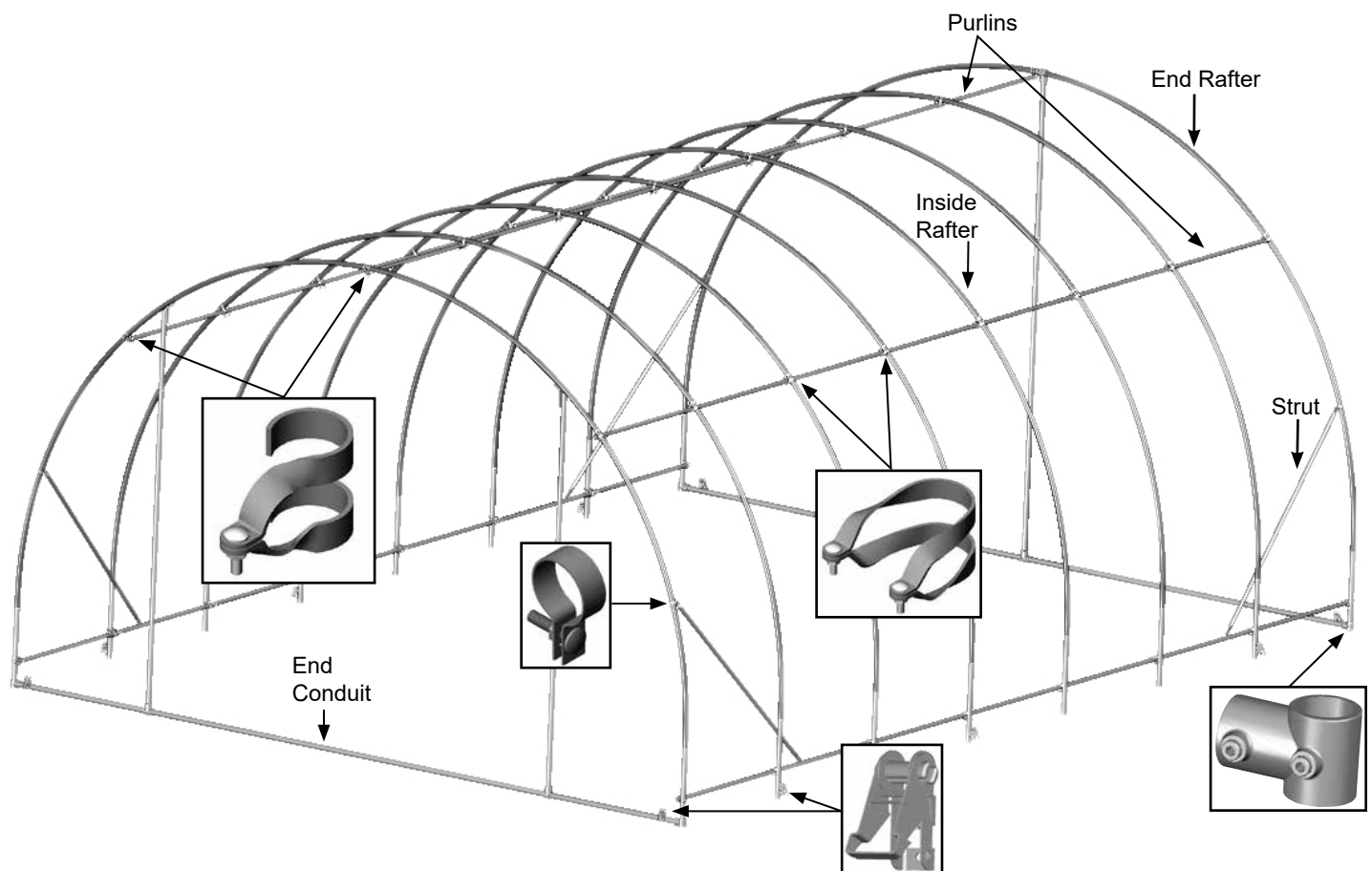

LAY OUT THE BUILDING SITE

After the site is prepared, identify the location of the shelter corners helps to square the frame after it is assembled.

Taking these steps **before** assembling the shelter saves time and ensures that the structure is positioned as desired. The following procedure is a suggested method. Its use depends on the size of the shelter, shelter application, the footings, and the method used to anchor the shelter.

SQUARE THE SITE

1. Identify a corner where a building rafter will be positioned, drive in a stake, and string a line the exact width of the building and stake in place.
2. Sting a line at least as long as the building from the first stake at 90°.

NOTE: A transit can be used to ensure an accurate 90° angle, or the 3-4-5 rule can be used. Refer to diagram. Using multiples of 3-4-5 such as 6-8-10 or 12-16-20 helps to maintain an accurate 90° angle.

3. After squaring the position of the building and placing a stake at all corners, string a line between the stakes to mark the base of the building.

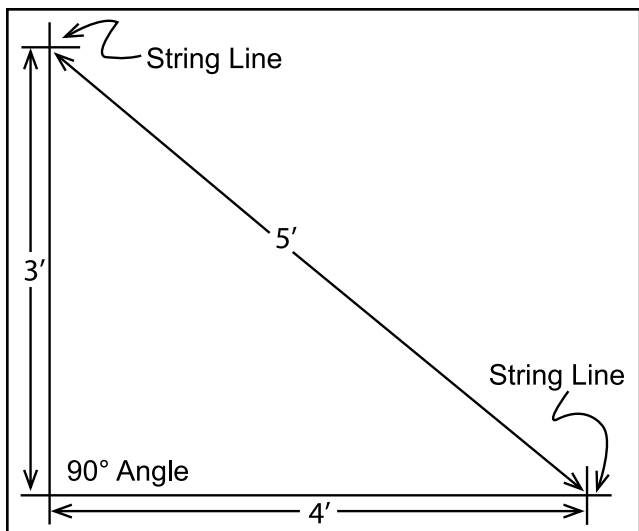

ASSEMBLING THE ROUND STYLE OVERSIZED GARAGE COMPONENTS

NOTE: Assistance is required to assemble the garage.

RAFTER ASSEMBLY

Gather the Parts:

- Rafter Pipe (#20R1601)
- Rafter Pipe (#20R1602)
- Rafter Pipe (#166S027)
- Purlin End Clamps (#102856)
- T-fitting (#10015107)
- Band Clamps (#QH1402)
- Tek Screws
- Nut Setter 3/8" x 2-9/16 Magnetic

Rafter Assembly Procedure:

Each rafter assembly consists of six (6) rafter sections: three (3) swaged sections, one (1) non-swaged section, and a pair of swaged extensions.

1. Select the six (6) pipes needed to assemble a rafter and arrange these on a flat surface as shown below for assembly.

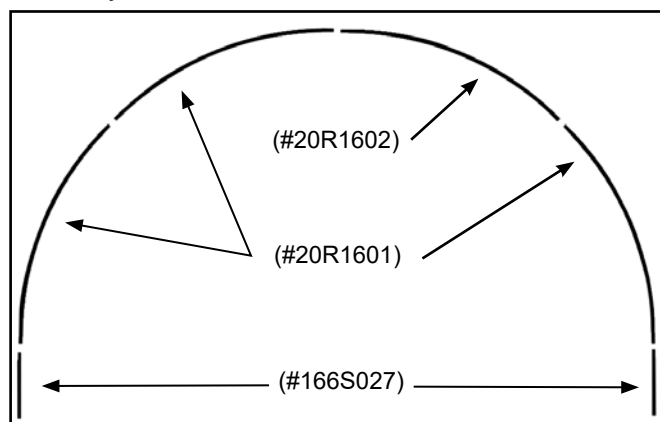

2. Slide the swaged portion of each rafter pipe into the plain end of the pipe as shown.

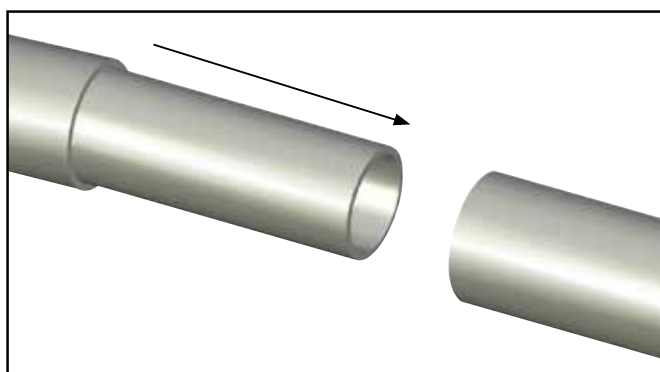

CLEARSPAN™ GARAGES & STORAGE SHEDS

RAFTER ASSEMBLY (CONTINUED)

- With the main rafter pipes seated at each joint and the rafter positioned on a flat surface, secure each joint with a single self-tapping Tek screw. Position Tek screw approximately 1" from pipe joint.

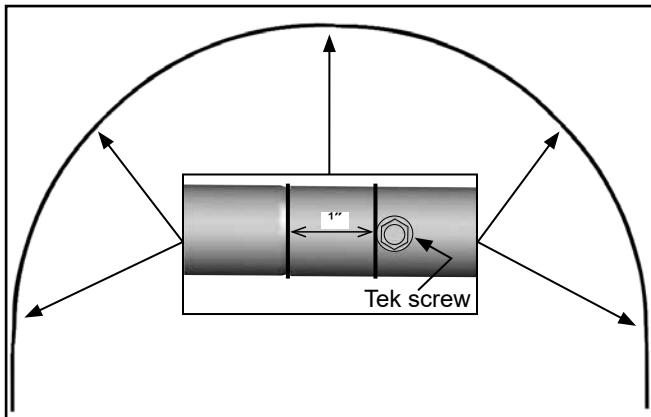

ATTENTION: Install the screws so they will not touch the cover once it is installed. This is typically on the backside of the rafter, which will be the surface visible from the *inside* of the shelter once the frame is assembled.

- Assemble all rafters as described except for two (2) and continue with the additional steps to assemble the two end rafters.

END RAFTER ASSEMBLY

In addition to the steps in the previous procedure, complete the following steps *for the end rafters only*.

- Select the six (6) pipes needed to assemble a rafter and arrange these on a flat surface.
- Slide a T-fitting (#10015107) onto the top section just inside the swaged end as shown in the illustration below.

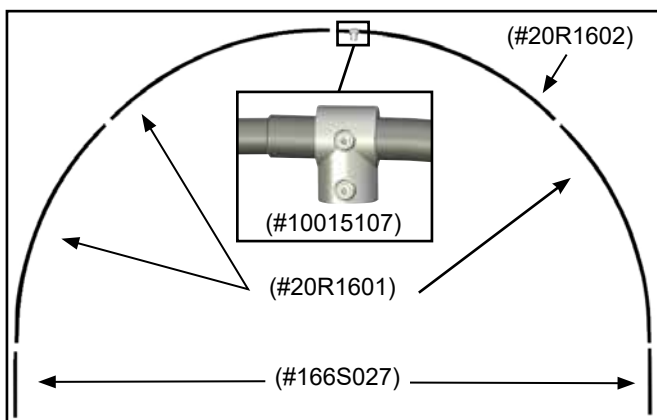

NOTE: The end rafter with the T-fitting (above) is used at the end of the shelter where the plain (no zipper) end panel is installed.

- Slide five (5) end clamps (#102856) and two (2) band clamps (#QH1402) onto the rafter in the locations noted below. (Do not secure the clamps to the rafter at this time. These clamps will be repositioned during the frame assembly when the purlins are added.)

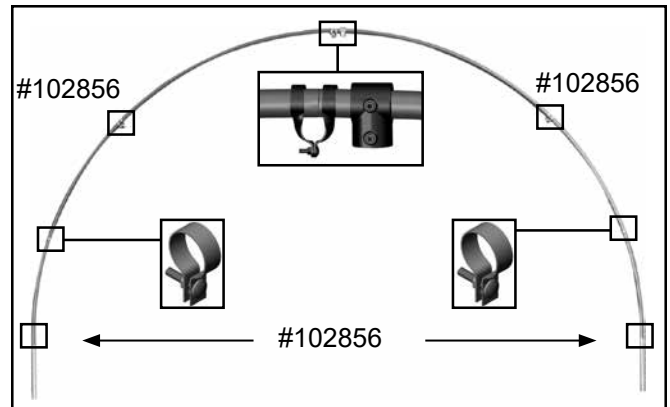

NOTE: Position all clamps as shown. Use a piece of duct tape to keep the clamps from sliding when the rafter is set in place (if needed).

View below shows how to position all end clamps to prepare for the frame assembly.

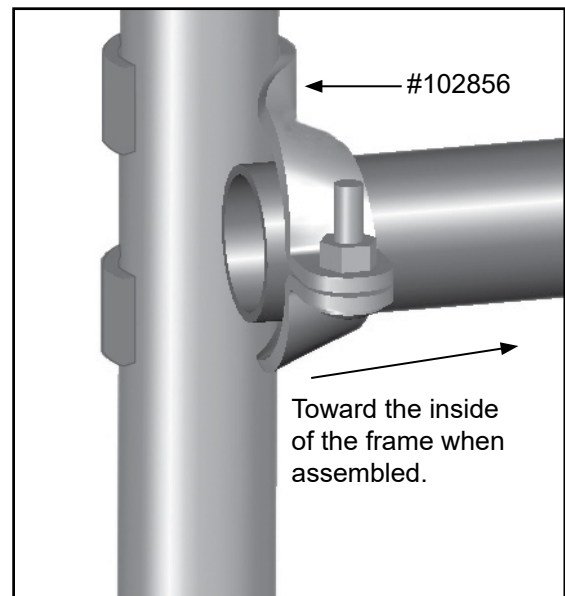

- Repeat the procedure for the remaining *end rafter* with *this exception*: the second end rafter **does not** use the T-fitting located at the top of the rafter.

NOTE: This end rafter is used at the door end of the shelter.

- Continue with the FRAME ASSEMBLY instructions that follow.

FRAME ASSEMBLY

Gather the Parts

- All Rafter Assemblies
- Pipe 1.315" x 75" Swaged
- Pipe 1.315" x XX" Plain
- Band Clamps (#QH1400)
- Strut 7' and Tek screws

Frame Assembly Procedure:

1. Stand one end rafter (one with the end clamps attached) and brace it in place as shown below. Check that the rafter is standing up straight (plumb). Position the bolt side of end clamp to the inside of the frame.

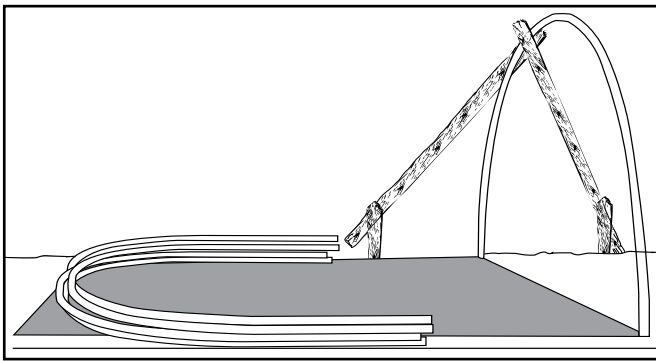

2. Insert the plain end of one 75" purlin pipe into each end clamp at the bottom of the end rafter. *The clamp must be 2" from the bottom of the end rafter to allow room for the T-fitting which will be added later.*

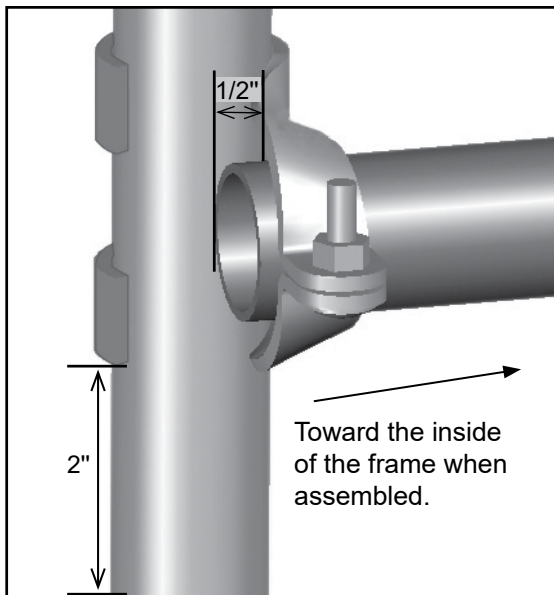

⚠ CAUTION: To prevent cover damage, the ends of the purlins should extend no more than 1/2" past the end clamp. The bolt side of the end clamps must go toward the "inside" of the shelter (the same side as the purlin) as shown above.

3. Position an inside rafter from the end rafter using the on-center, rafter-to-rafter spacing of 48". (Additional help is required to hold the rafters in position.)

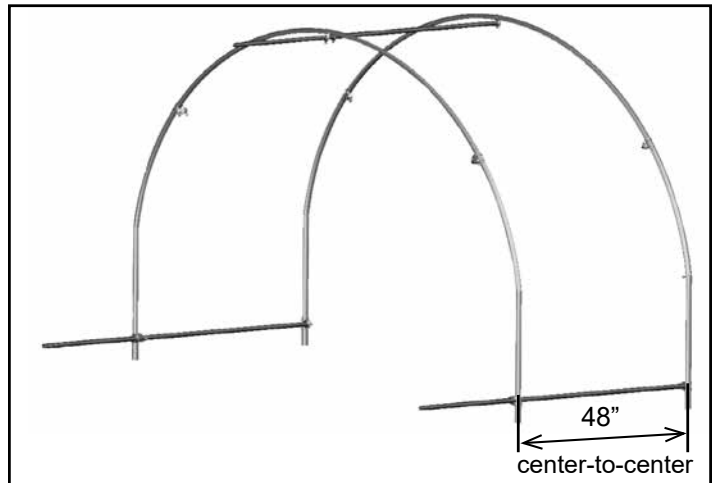

Shelter shown above may be a different model.

4. Install a cross connector and insert the purlin pipe through the connector at the top of the interior rafter and also through the end clamp at the top of the end rafter.
5. Verify that both rafters are plumb and properly spaced on center.
6. Tighten the cross connector at the top of the interior rafter and tighten the end clamp at the top of the end rafter.
7. Slide a band clamp (#QH1400) on each of the two bottom purlins between the second and third rafters. Make sure the heads of the band clamp bolts are toward the outside of the shelter.

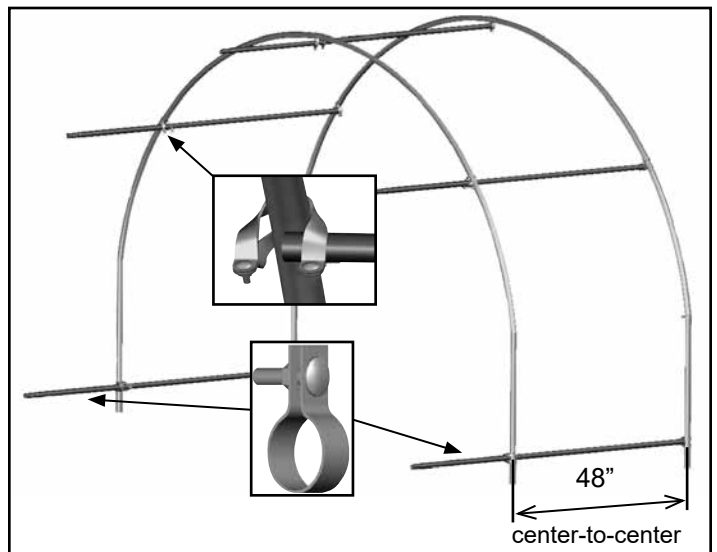

Shelter shown above may be a different model.

CLEARSPAN™ GARAGES & STORAGE SHEDS

FRAME ASSEMBLY (CONTINUED)

8. Move to the lower end of the rafters and verify that the position of the purlin is 2" up from the finished grade.

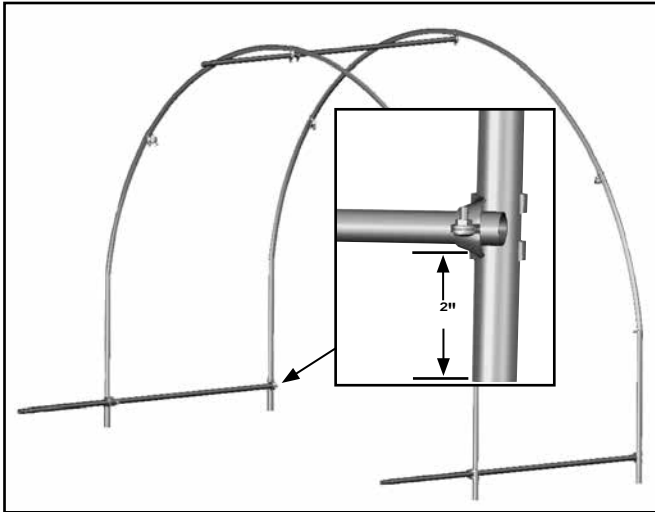

9. Install the remaining purlins. Verify that the rafter spacing is the correct on-center dimension for the shelter and tighten the connectors.

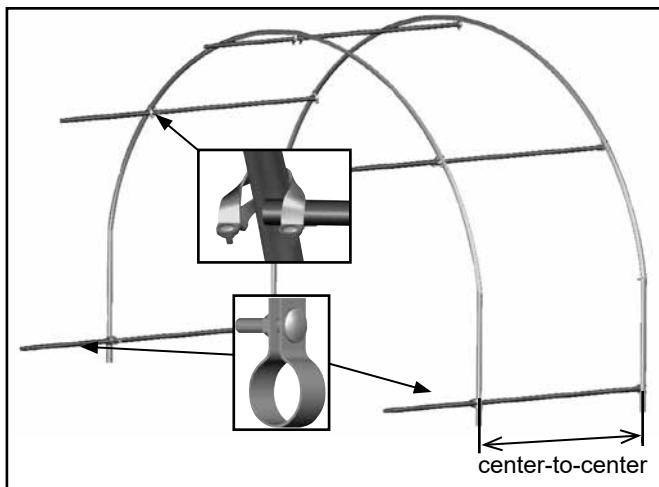

10. Continued adding rafters and purlins until the frame is assembled.

NOTE: Remember to add band clamps to the lower purlins between the second and third rafter at the remaining end of the frame for the installation of the struts.

Each purlin assembly consists of 1.315" x 75" (#131S075) swaged pipes (number is determined by shelter length) and one (1) 1.315" x XX" (#131P0XX) plain pipe.

The XX" represents the remaining length needed to reach the end of the frame. Consult the Spec Sheet for part identification.

11. Finish each purlin run using the plain, shorter pipe (#131P0XX), and use the final end rafter to complete the assembly.

NOTE: If the last end rafter is plumb and the purlin run extends beyond the end of the rafter, cut the last section of purlin pipe to the required length.

Typically purlin pipes *do not* require cutting. Verify that the finished purlin run has the correct plain pipe before cutting any pipe.

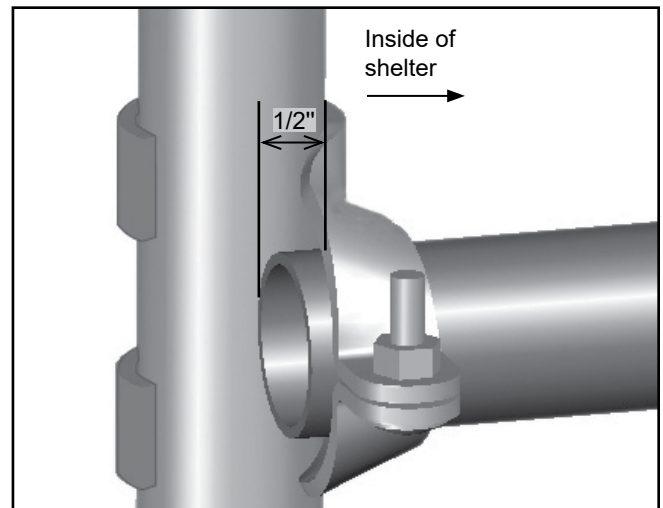

CAUTION: To prevent cover damage, the ends of the purlins should extend no more than 1/2" past the end clamp. The bolt side of the end clamps must go toward the "inside" of the shelter (the same side as the purlin) as shown.

12. Return to each clamp and install a Tek screw through the clamp and into the purlin pipe as shown.
13. Secure each clamp to the rafter using a Tek screw.

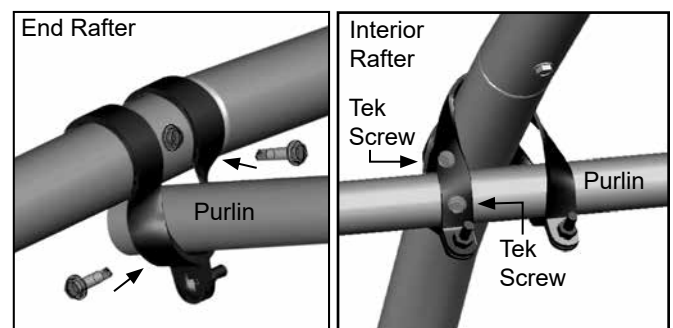

FRAME ASSEMBLY (CONTINUED)

Strut Assembly Procedure

1. After the rafter assembly is complete, verify that the band clamps are in the proper location. See diagram below.

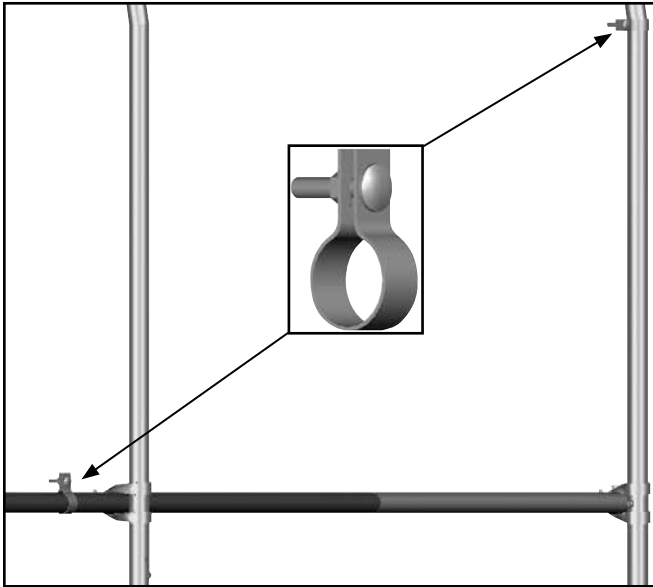

2. Remove the bolts and attach a strut between the band clamp on the purlin and the band clamp on the end rafter. Position the strut so that it forms a triangle as shown below.

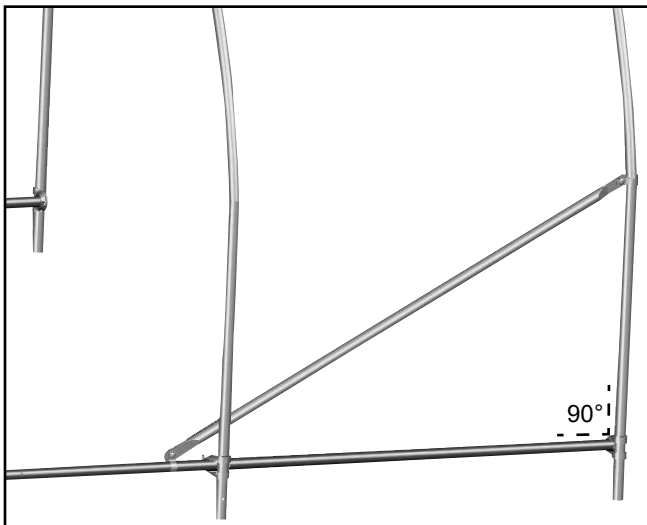

NOTE: Verify that the bolt heads are to the outside of the shelter and that the end rafter is plumb before tightening the nuts.

3. Install the remaining struts and tighten all band clamp bolts.
4. Secure each band clamp to each purlin or rafter with a Tek screw.
5. Return to each purlin joint and secure using a Tek screw.

SQUARE THE ASSEMBLED FRAME

Gather the Parts

- Measuring tape
- Tek Screws

Complete these steps:

1. Square the frame by measuring diagonally corner-to-corner and align all rafters as shown below.
2. Verify that the width of each rafter is 20' center-to-center.

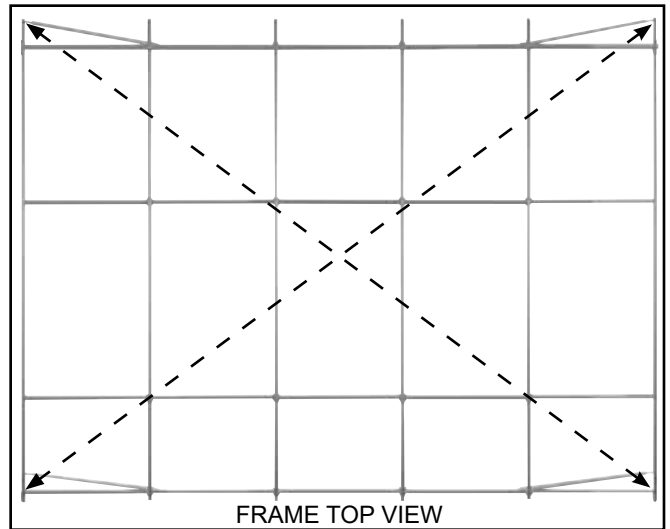

NOTE: The frame is square when the two diagonal measurements are the same.

3. Tape all rafter splices with duct tape to protect the main cover when it is installed.
4. Verify that all pipe splices and clamps are secured using Tek screws.

FINISH ROUGH EDGES

Gather the parts:

- Duct tape (supplied by customer)
- Metal file (may not be needed)

1. Check for any sharp edges on the frame and file them smooth so they will not cut the cover.
2. Apply two layers of heavy duct tape on all pipe connections and clamps that may contact the cover.

CLEARSPAN™ GARAGES & STORAGE SHEDS

END CONDUITS ASSEMBLY

Gather the Parts:

- Pipe 1.66" x 48" Plain (2)
- Pipe 1.66" x 99" Swaged (4)
- T-fittings

Plain End Conduit Assembly Procedure

NOTE: This conduit is used with the plain (non-zippered) end panel and will be attached to the end rafter with the T-fitting at the top.

1. Locate the end conduit pipes and T-fittings. Plain end conduit consists of one (1) 48" pipe, two (2) 99" pipe, and three (3) T-fittings.
2. Assemble the end conduit by connecting the two (2) swaged pipes and the plain pipe.
3. Slide one (1) T-fitting onto the center of end conduit assembly.
4. Add one (1) T-fitting at each end of the conduit.

NOTE: Do not tighten the Allen bolts on the T-fittings at this time.

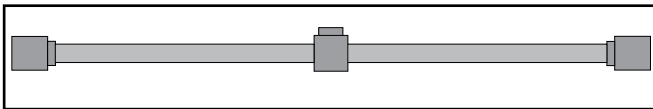

Zippered End Conduit Assembly Procedure

NOTE: This conduit is used with the zippered end panel and will be attached to the end of the shelter where the door is located.

1. Locate the end conduit pipes and T-fittings. Zippered end panel conduit consists of one (1) 48" pipe, two (2) 99" pipe, and four (4) T-fittings.
2. Assemble the end conduit by connecting the two (2) swaged pipes and the plain pipe together.
3. Slide two (2) T-fittings onto the end conduit assembly. The T-fittings will coincide with the flaps just outside each door zipper where the vertical supports will be installed.
4. Add one (1) T-fittings at each end of the conduit.

NOTE: Do not tighten the Allen bolts on the T-fittings at this time.

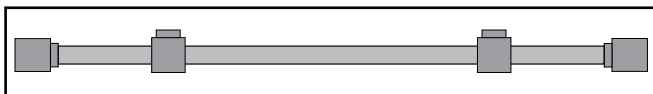

PREPARE END PANELS

CAUTION: To prevent damage, do not install end panels on a windy day.

Gather the Parts:

- Pipe 1.66" x 48" Plain (1)
- Pipe 1.66" x 99" Swaged (1)
- End Panel Solid (Plain)
- End Panel 2-Zip (Zippered)
- End Conduit Assemblies
- Tek screws
- Duct Tape and scissors

Plain End Panel Assembly Procedure (no zippers)

1. Prepare the panel: If the corners of the plain end panel have not been cut out, follow this procedure:
 - a. Place the plain end panel on a clean flat surface.
 - b. Position the plain end conduit assembly centered side-to-side on top of the hem. (This is the conduit with the three T-fittings.)
 - c. With scissors, trim the corners and middle of the end panel. (Example below shows trimming on dotted line so the T-fitting is exposed when conduit is placed inside the hem.)



2. Remove the T-fittings from the conduit assembly.
3. Slide the end conduit assembly into the hem at the bottom of the solid (plain) end panel.
4. Add the middle T-fitting (pointing UP with the mounting screws exposed) onto the assembly as it slides through the middle hem opening.

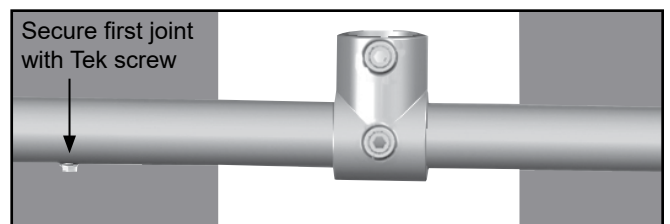

View from inside the hem.

PREPARE END PANELS (continued)

5. Secure the first pipe connection with a Tek screw as it passes through the middle hem opening. Tape over the Tek screw to protect the end panel.
6. Add a Tek screw to the joint of the last pipe connection before it enters the hem of the end panel. Tape over the Tek screw to protect the end panel.

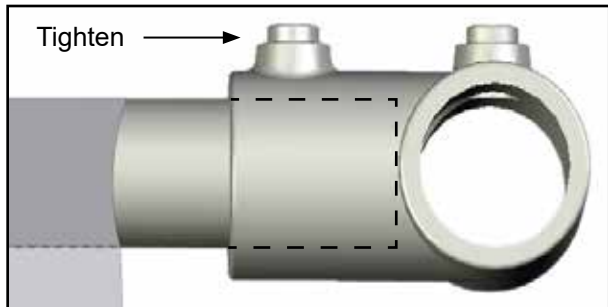

7. Attach two (2) T-fittings to the conduit ends; tighten only the Allen screws to the inside of the conduit. See arrow.

NOTE: Do not insert the end conduit pipes all the way into the T-fittings, but instead allow room for the end rafter to be inserted later.

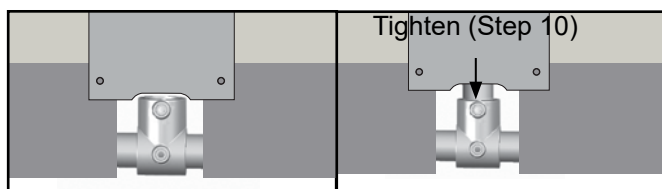

8. Using a 99" swaged pipe and 48" plain pipe create a vertical conduit. Secure the joint with a Tek screw and tape the Tek screw to protect the panel.
9. From the opening on the curved side of the end panel, insert the vertical conduit into the pocket and into the T-fitting at the middle of the end conduit.
10. Tighten the Allen screw in the T-fitting to secure the vertical conduit.
11. Using a scissors, trim the pocket material (not the end panel material) to expose the top of the vertical conduit as shown below.

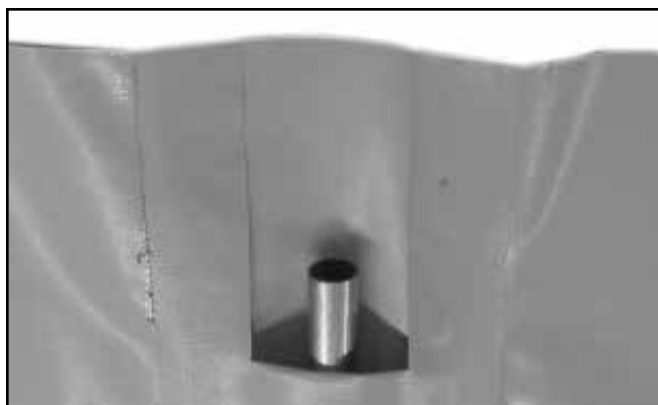

Zipper End Panel Assembly Procedure

1. Prepare the end panel. If the corners of the zipper end panel have not been cut out, follow this procedure:
 - a. Place the zippered end panel out on a clean flat surface.
 - b. Position the zippered end conduit assembly centered side-to-side on top of the hem.
 - c. Slide the two (2) T-fittings to coincide with the flaps just outside each door zipper where the vertical supports will be located.
 - d. With scissors, trim the corners and vertical support positions of the end panel as required so the T-fittings will be exposed when the tubing is placed inside the hem.

2. Remove the T-fittings from the end conduit assembly.
3. Secure the two (2) 99" swaged pipes at the joint using a Tek screw and tape the Tek screw to protect the cover.
4. Slide the assembled end conduit pipe into the hem at the bottom of the zippered end panel.

NOTE: Do not insert the conduit through the roll-up door panel of the end panel.

5. Add one of the vertical T-fitting (pointing UP with the mounting screws exposed) onto the assembly after it has slide through one section of the side panel.
6. Align the first T-fitting with the zippered end of the panel and attach another T-fitting onto the end conduit by the other zippered door panel.

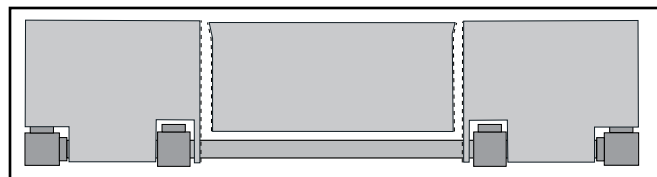

7. Secure the final pipe (48" plain) to the end conduit using a Tek screw and tape the Tek screw to protect the cover.
8. Fasten two (2) T-fittings onto the ends of the conduit.

NOTE: Do not insert the end conduit pipes all the way into the T-fittings, but instead allow room for the end rafter to be inserted later.

9. Continue with the procedure that follows.

CLEARSPAN™ GARAGES & STORAGE SHEDS

ATTACH END CONDUIT ASSEMBLIES

1. Verify that the end conduit of end panel is properly inserted into the T-fittings.

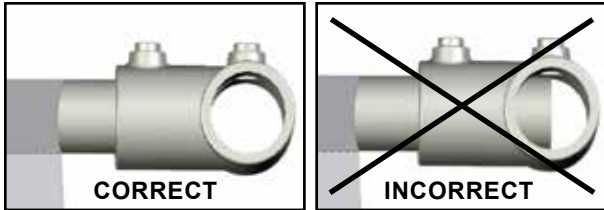

ATTENTION: Do not allow the end conduit to extend into the opening that remains for the bottom of the end rafter.

2. Position the end panel as desired and insert the bottom of the end rafter into the T-fitting of the end conduit.
3. Verify that the rafter pipe is flush with the bottom of the T-fitting and tighten the Allen screws to secure the connection.
4. Repeat the steps for the remaining end panel.

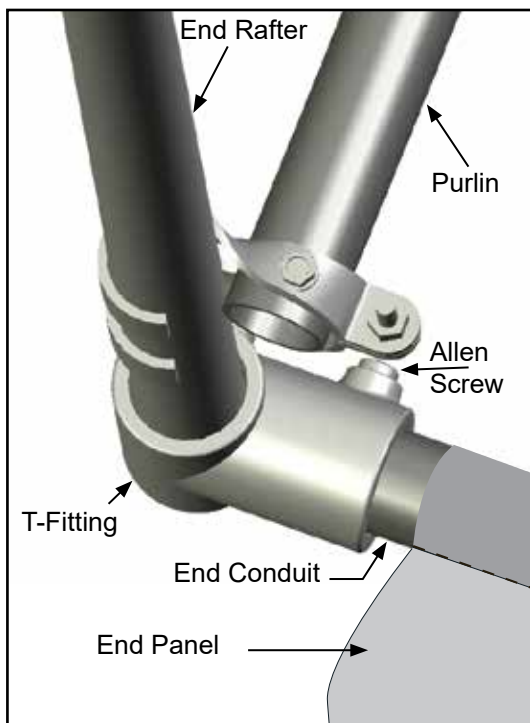

ANCHOR THE SHELTER

At this point, anchor the shelter. Consult the MUST READ document for anchoring information and suggestions. Please call customer service at 1-800-245-9881 for additional anchoring information.

CAUTION: The anchor assembly is an integral part of the shelter construction. Improper anchoring may cause shelter instability and failure of the structure to perform as designed. Failing to anchor the shelter properly will void the manufacturer's warranty and may cause serious injury and damage.

ATTACH END PANEL ASSEMBLIES

Gather the Parts:

- Pipe 1.66" x 48" Plain (2)
- Pipe 1.66" x 99" Swaged (2)
- Fabric Clips #CC6213 for 1.66" diameter pipe
- QH1330 Brackets (2) for door end panel
- Tek Screws, scissors, rope, and tape measure

Plain End Panel Assembly Procedure (no zipper)

1. Securely attach a rope to the exposed end of the vertical conduit and throw the rope up and over the end rafter. Temporarily secure rope or strap using a Tek screw. Remove after conduit is secured to fitting.

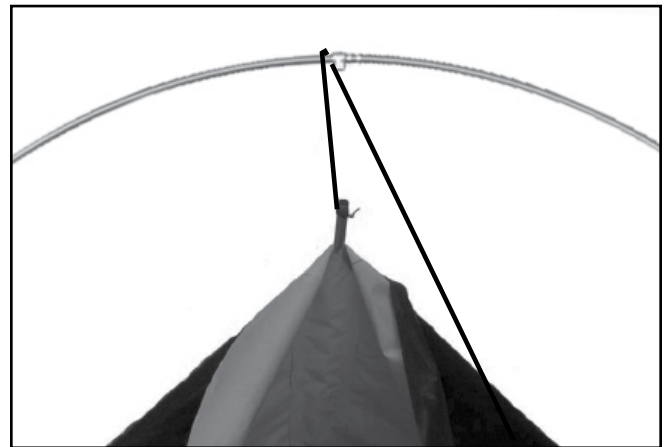

WARNING: To avoid injury, *do not* allow anyone to stand under the conduit as it is installed. Do not install panels or cover on a windy or stormy day.

2. Center the conduit and insert the upper end of the vertical conduit into the T-fitting at the peak of the end rafter. Tighten the Allen screws in both T-fittings.



3. While standing inside the shelter, start at the peak of the end rafter and pull the solid (plain) end panel over the top of the rafter so the panel edge is wrapped to the inside of the rafter.

ATTACH END PANEL ASSEMBLIES (continued)

4. Divide the quantity of CC6213 fabric clips in half and use half for each panel.
5. Secure the solid end panel in place at the top center of end rafter with one fabric clip and Tek screw.
6. Take the remaining fabric clips for the first panel and secure the panel to the back of the rafter using the clips and Tek screws.

NOTE: Secure each fabric clip to the end rafter using a Tek screw. Position the clip and the Tek screw in a location that will not contact the cover when it is installed.

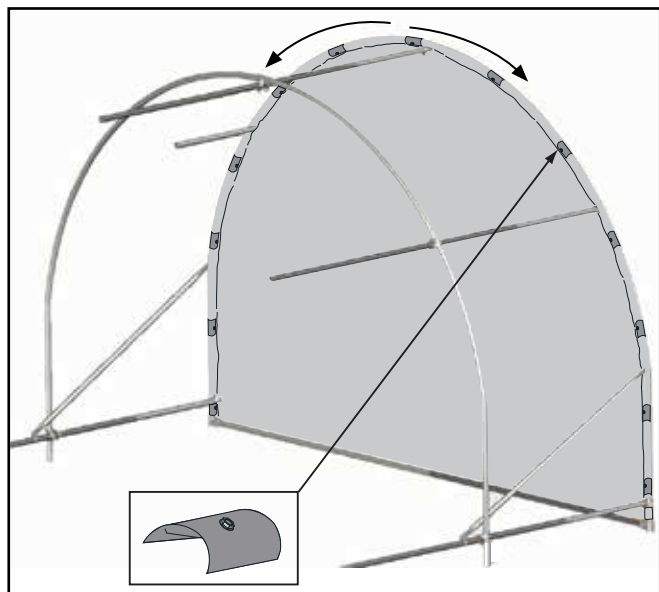

The end panel may be shipped as an untrimmed rectangular piece. If desired, use scissors (or other means) to trim the excess end panel material that remains inside the shelter where the panel is secured to the rafter.

The number of fabric clips used to secure the end panel to the end rafter for your building may differ from the number shown in the diagram shown above.

IMPORTANT: To prevent running short on the CC6213 fabric clips, remember to **use half for one end panel and half for the other end panel.**

Zipper End Panel Assembly Procedure

1. Measure along the door opening of the end panel from the top of the end panel conduit to the underside of the end rafter to determine the length of each vertical conduit for the zippered end panel.
2. Using a 99" swaged and a 48" plain pipe, assemble one vertical conduit, secure the joint using a Tek screw, and cut the conduit to the length determined in Step 1.
3. Tape over the Tek screw to protect the panel and repeat the steps to assemble the final vertical end panel conduit.
4. Slide one conduit into each of the vertical pockets in the end panel running along the zippers.
5. Attach each conduit to a T-fitting on the end conduit next to the door opening. *Tighten the upper Allen screw in each T-fitting to secure the vertical conduits in the fittings.*

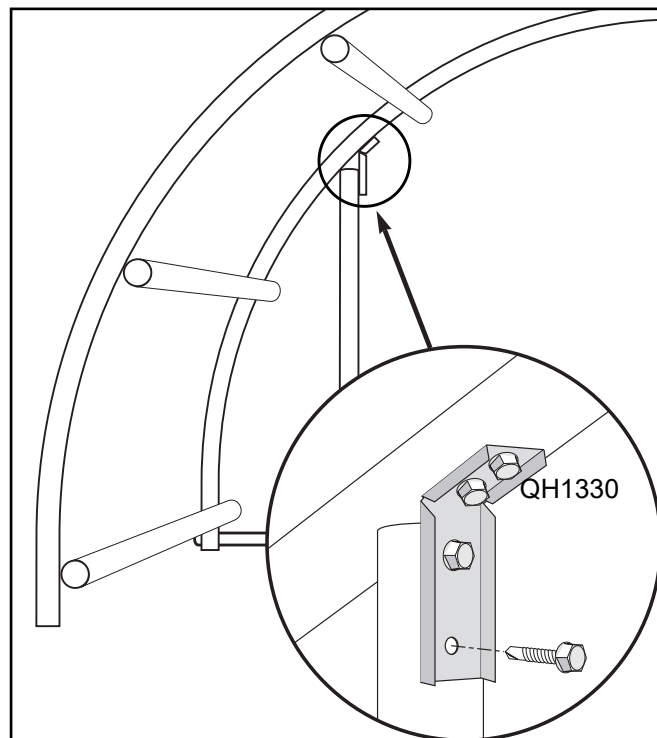

6. Adjust the conduits so they are vertical/plumb and fasten the upper end of each conduit to the end rafter using a QH1330 bracket and Tek screws as shown in the illustration above. (Panel is not shown.)
7. Pull the end panel over the end rafter and secure it using fabric clips and Tek screws as described in the previous section.
8. Check and retighten all Allen screws for all fittings of both end panels.
9. Continue with the next section.

CLEARSPAN™ GARAGES & STORAGE SHEDS

INSTALL ROLL-UP CRANK ASSEMBLY

Gather the Parts:

- Pipe 1.315" x 75" Swaged (1)
- Pipe 1.315" x 73.5" Plain (2)
- Spin Handle
- Universal Joint
- Fabric Clips (#CC6212)

Assembly Procedure:

1. Assemble the roll-up door conduit by connecting the 75" swaged pipe to one (1) 73.5" plain pipe, secure the joint using a Tek screw, and tape over the Tek screw to protect the end panel.
2. Insert the conduit assembly into the door pocket. When installed correctly, the conduit is flush at one end of the roll-up panel and will extend an inch or so beyond the other end of the panel where the crank will be attached.
3. Secure the conduit to the panel using CC6212 fabric clips as shown below. Evenly space the clips.

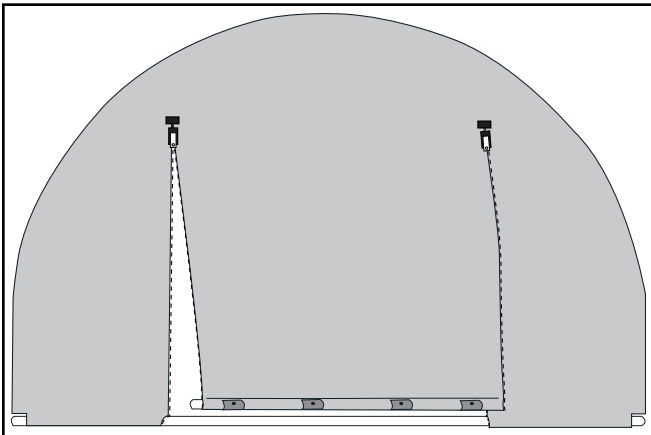

4. Attach the universal joint to the conduit in the pocket using a Tek screw to secure the connection.

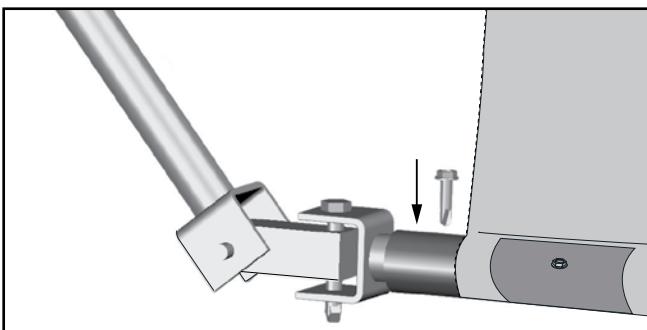

5. Using one (1) 73.5" plain pipe as the extension pipe, secure the extension pipe to the remaining end of the universal joint using a Tek screw.

NOTE: The extension pipe can be trimmed to the desired length if needed.

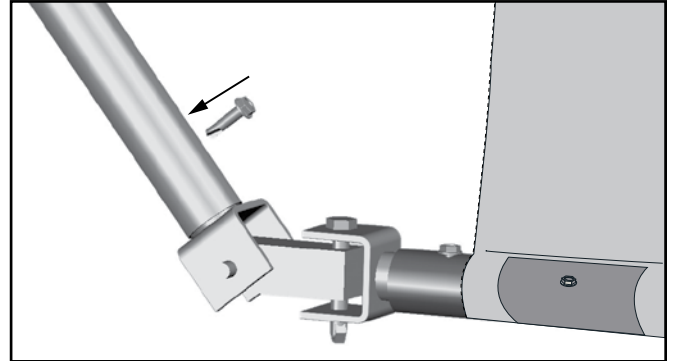

6. Add the spin handle to the extension pole and secure the connection with a Tek screw.

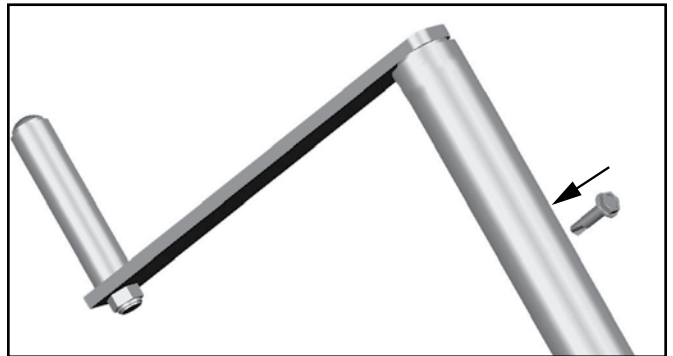

The roll-up crank assembly is now complete and is shown below.

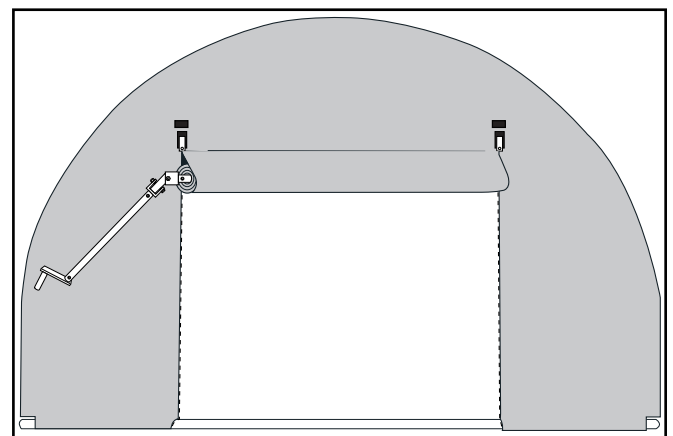

NOTE: If equipped, use the zipper extension pole to zip and unzip the door panel on tall buildings. (May require an additional purchase.)

PREPARE MAIN COVER

Gather the Parts:

- Ratchets (1" 4000lb)
- Pipe 1.315" x 75" Swaged
- Pipe 1.315" x XX" Plain
- Main Cover
- Tek Screws

Assembly Procedure:

NOTE: When handling the main cover and setting it in position, do not pull on the end straps. They will pull out of the cover.

⚠ WARNING: To prevent damage to the cover and to prevent serious personal injury, DO NOT attempt to install the main cover on windy days.

1. Fasten a ratchet to the end conduit with a Tek screw in the bottom hole of the ratchet as shown below. The ratchet should be about 6" in from the end of the conduit. Repeat this step in all four corners.

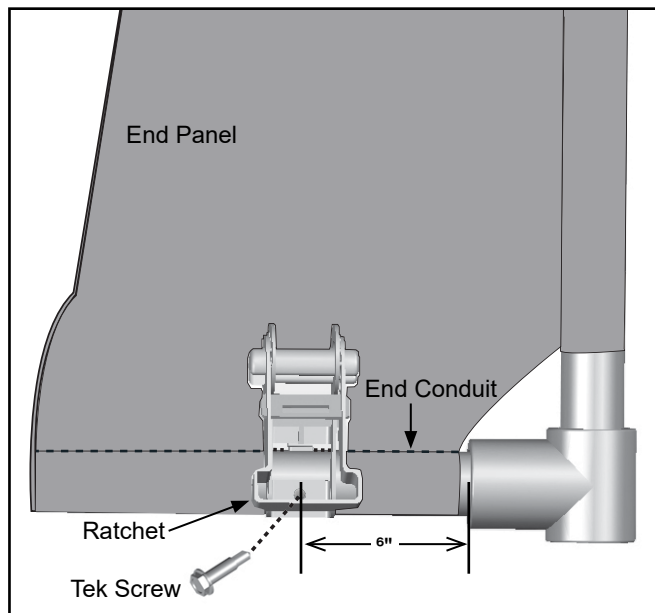

2. Assemble two main cover conduits. Start each conduit assembly with one plain pipe and add swaged pipes to arrive at the correct length. *This conduit is identical to the purlins that are attached to the frame.*
 - a. Locate all sections of pipe needed to assemble the cover conduit.
 - b. Insert the swaged end of each pipe into the plain end of another pipe until the conduit is assembled.
 - c. Secure each pipe joint with a Tek screw.



NOTE: Duct tape Tek screws to prevent damage to main cover.

These cover conduits are inserted into the pockets sewn into the main cover. The conduits are used to tighten and secure the main cover.

3. After assembling the cover conduits, locate the main cover and unfold it on a clean, smooth surface near the frame.

NOTE: Unfold the main cover with the inside surface facing up.

4. Locate the cover ends with strapping and align with the front and back of the shelter.
5. Insert the cover conduits into the pockets of the main cover.

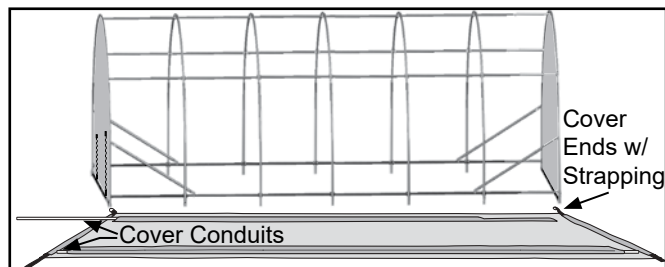

NOTE: Shelter shown above may be of a different length than actual shelter.

CLEARSPAN™ GARAGES & STORAGE SHEDS

ATTACH MAIN COVER

Gather the Parts:

- Main cover (with conduits already inserted)
- Ropes long enough to reach over the frame (provided by customer).
- Ratchets (1" 4000lb)
- Tek screws
- Box cutter or utility knife

Assembly Procedure:

1. To pull the cover over the frame, attach ropes to both ends of the cover conduit. Wrap the rope around the conduit a few times to prevent it from slipping off.

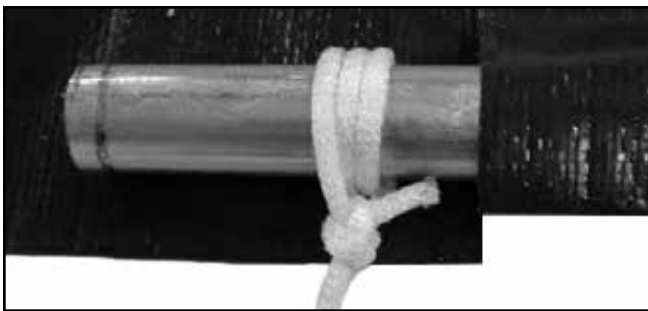

NOTE: Depending on the length of the cover it may be necessary to attach additional ropes to the cover conduit between the end ropes by cutting a small opening in the cover pocket and tying the rope around the conduit. **DO NOT** cut through the main cover. *Cut through the conduit pocket only.*

2. With all ropes attached to the cover conduit, lift the conduit and carry the cover toward the base of the frame.
3. Toss the ropes over the frame and pull the cover into position. One person is required at each rope.

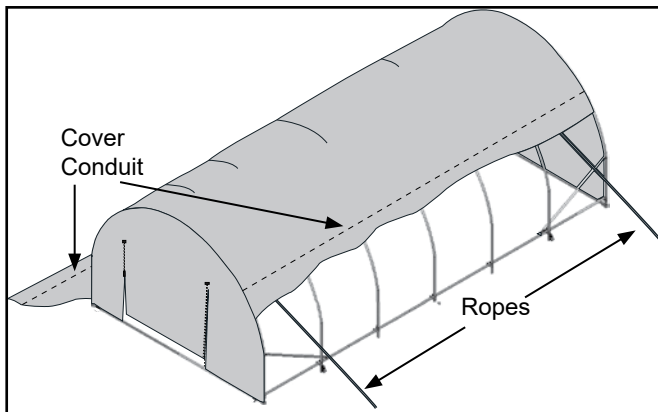

Shelter shown above may be a different length.

4. Once the main cover is pulled into position, center the cover on the frame and remove the ropes. Loosely secure the ends of the cover to the ratchets attached to the front and back end panel conduits.

ATTENTION: Do not tighten the straps at this time

5. Divide the remaining number of ratchets in half. Place the ratchets on the ground next to the rafter where they will be attached.

NOTE: Ratchets are evenly spaced long each side of the shelter and directly across from each other on the *same rafter assembly*. Rafters are identified by the arrows below.

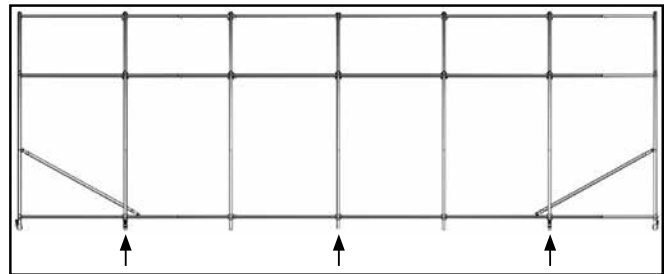

NOTE: Diagram above is an example of the 24' shelter.

6. Using the main cover conduit as a guide, attach the ratchets to the rafters at the proper height. Fasten ratchets to the outside of these rafters using a Tek screw.

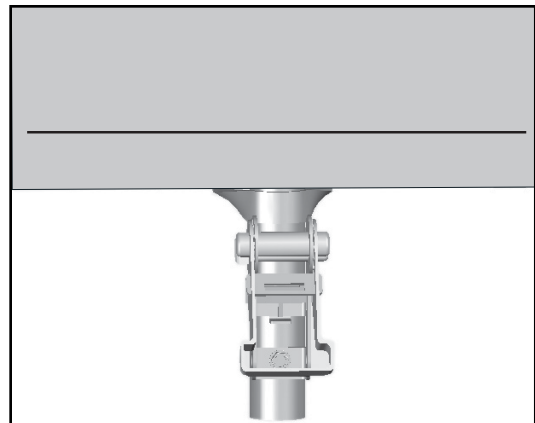

7. Lift the cover skirt and cut a slit in the cover conduit at the rafter position. Insert a 3' section of strap through the slit and around the cover conduit.

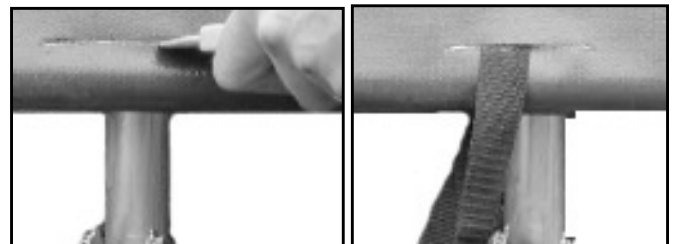

NOTE: **DO NOT** cut through the main cover. *Cut through the conduit pocket only.*

ATTACH MAIN COVER (CONTINUED)

8. Thread the strap ends into the ratchet and slightly tighten.

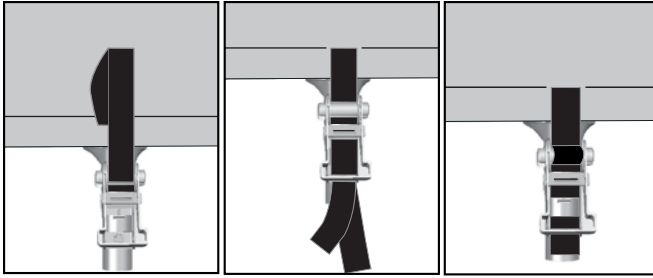

NOTE: It may be necessary to remove excess strap if it binds up in the ratchet.

9. Repeat the steps for the remaining ratchets.
10. Using additional help (if needed) tighten the main cover beginning with the ratchets along the side of the shelter frame.
11. After the side ratchets are tightened, return to the front and back end wall ratchets and tighten.

NOTE: Loosen the ratchets if needed to remove excess strap and retighten. Loosen all ratchets if needed to reposition the main cover on the frame and retighten the ratchets.

12. Fold the skirt of main cover down and over the ratchets to complete the installation of the main cover.

SHELTER CARE AND MAINTENANCE

Proper care and maintenance of your shelter is important. Check the following items periodically to properly maintain your shelter:

- Regularly check the main cover and panels (if equipped) to see that these remain tight and in proper repair.
- Check connections and all fasteners to verify that they remain tight.
- Do not climb or stand on the shelter at anytime.
- Remove debris and objects that may accumulate on the shelter. Use tools that will not damage the cover when removing debris.
- Remove snow to prevent excess accumulation. Use tools that will not damage the cover when removing snow.
- Check the contents of the shelter to verify that nothing is touching the cover or the side panels that could cause damage.
- Check the anchoring system to ensure that all components are tight and in good repair.
- If the shelter is moved, inspect all parts and connections before reassembling.
- For replacement or missing parts, call 1-800-245-9881 for assistance.

NOTE: With the exception of Truss Arch buildings, ClearSpan™ shelters and greenhouses *do not* have any tested loading criteria.



QUICK START GUIDE

20' Wide Round Style Oversized Garage

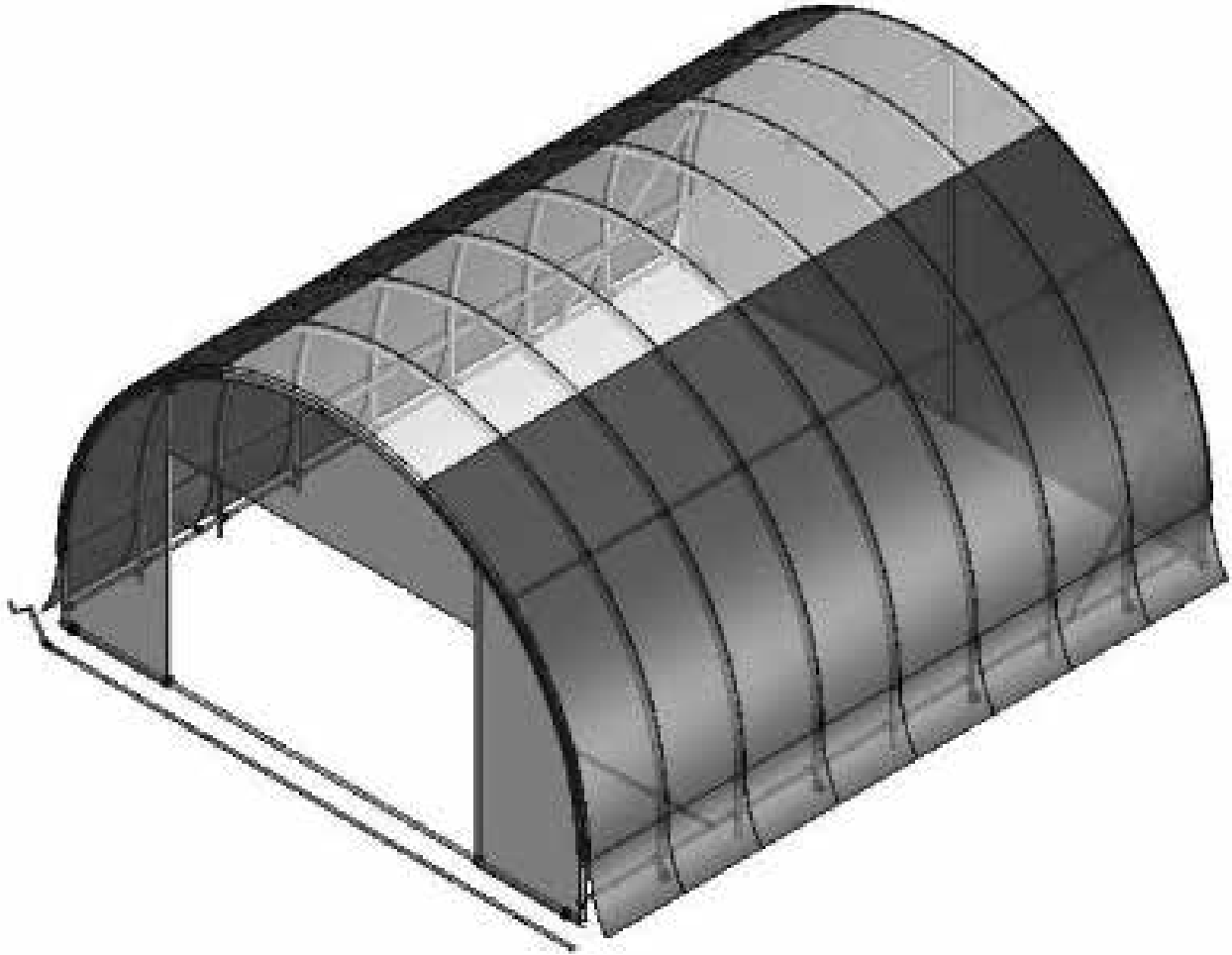

Frame shown may vary in length from actual frame.

FRONT PROFILE

Connection Note

Purlin connected to end rafters using 102856 clamp - See View 1

Purlin connected to mid rafters using 102548 cross connector - See View 3

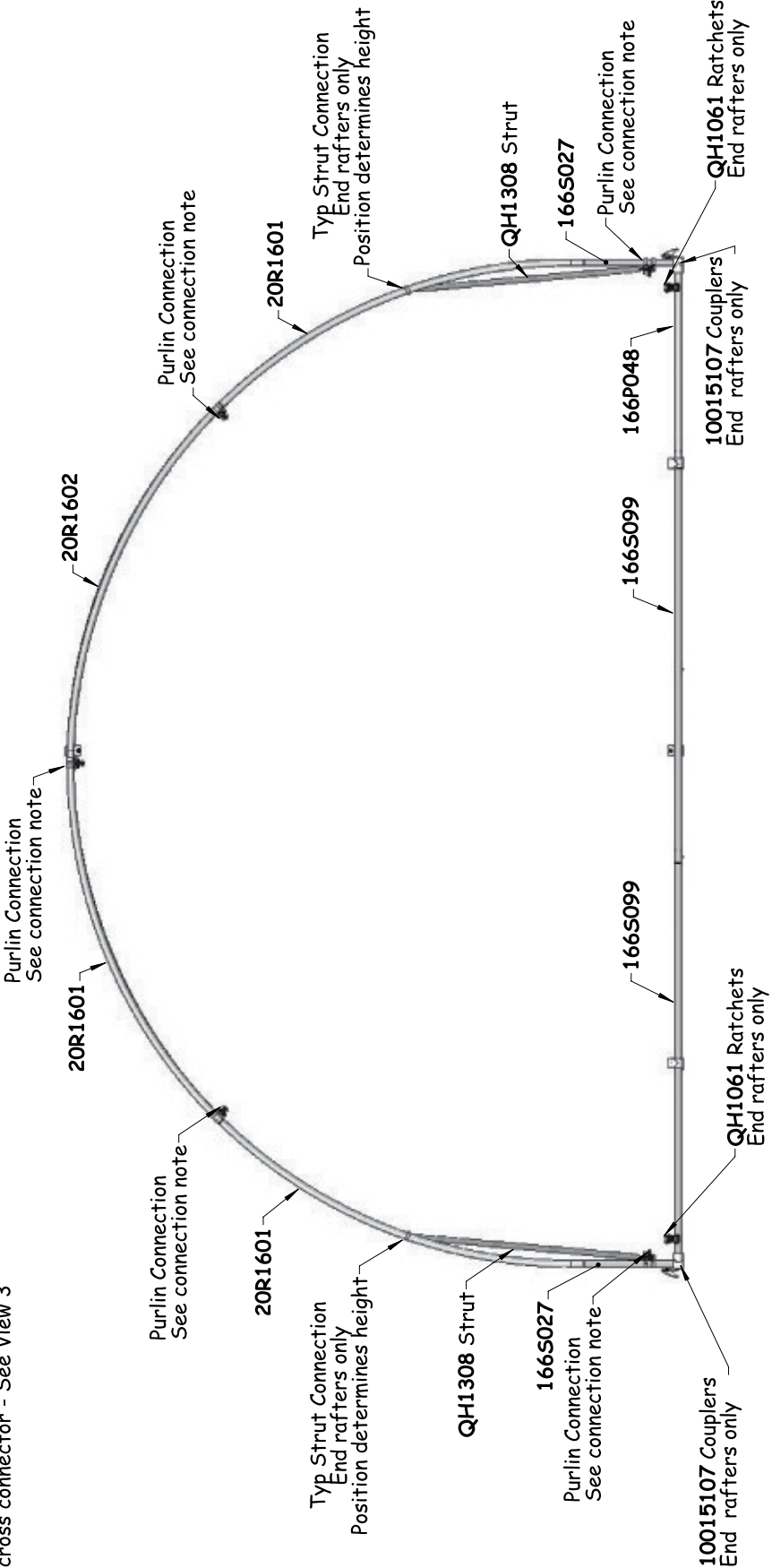

NOTE: End conduit only installed on End Rafters

SIDE PROFILE - PB01400R4

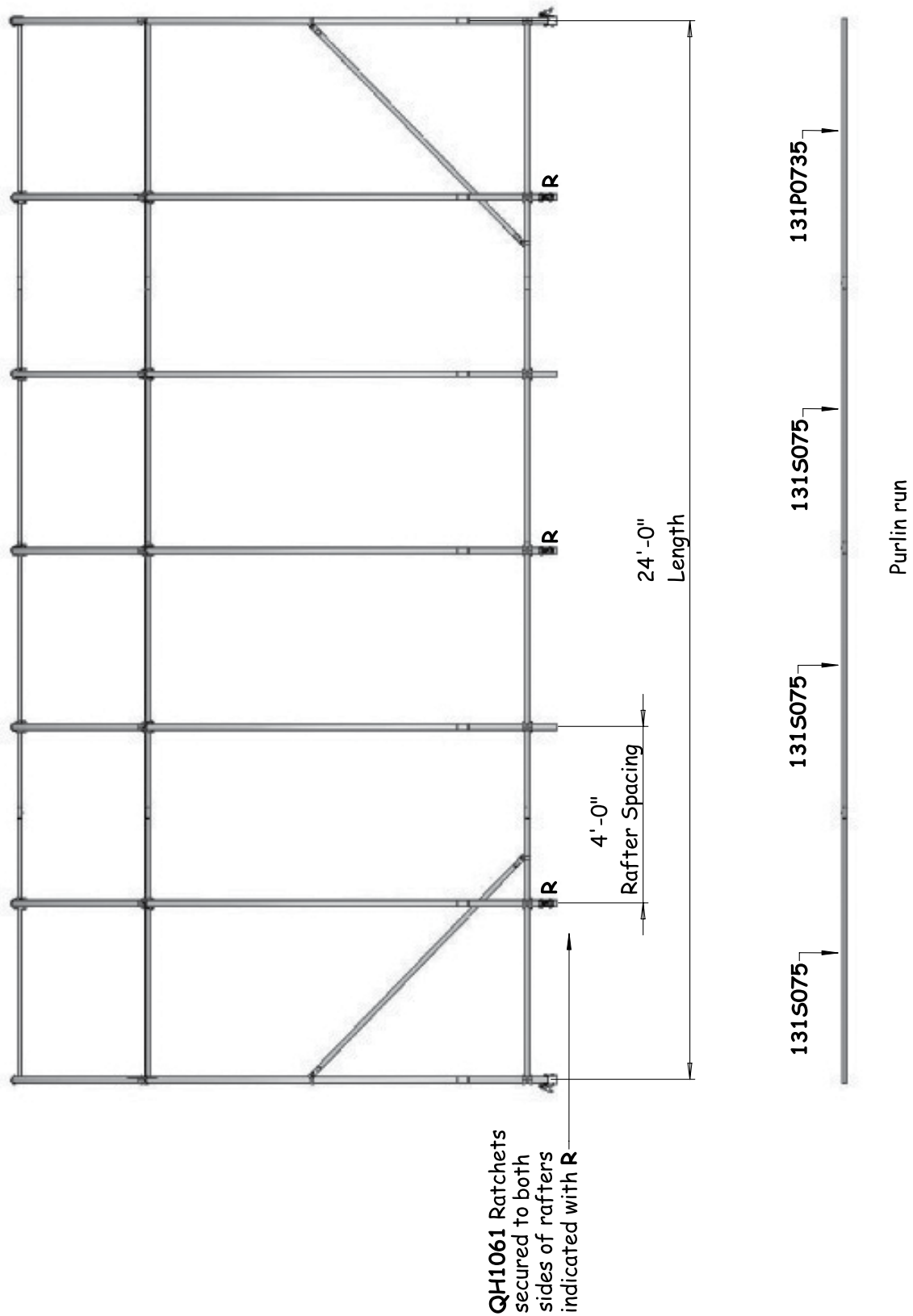

SIDE PROFILE - PB01420R4

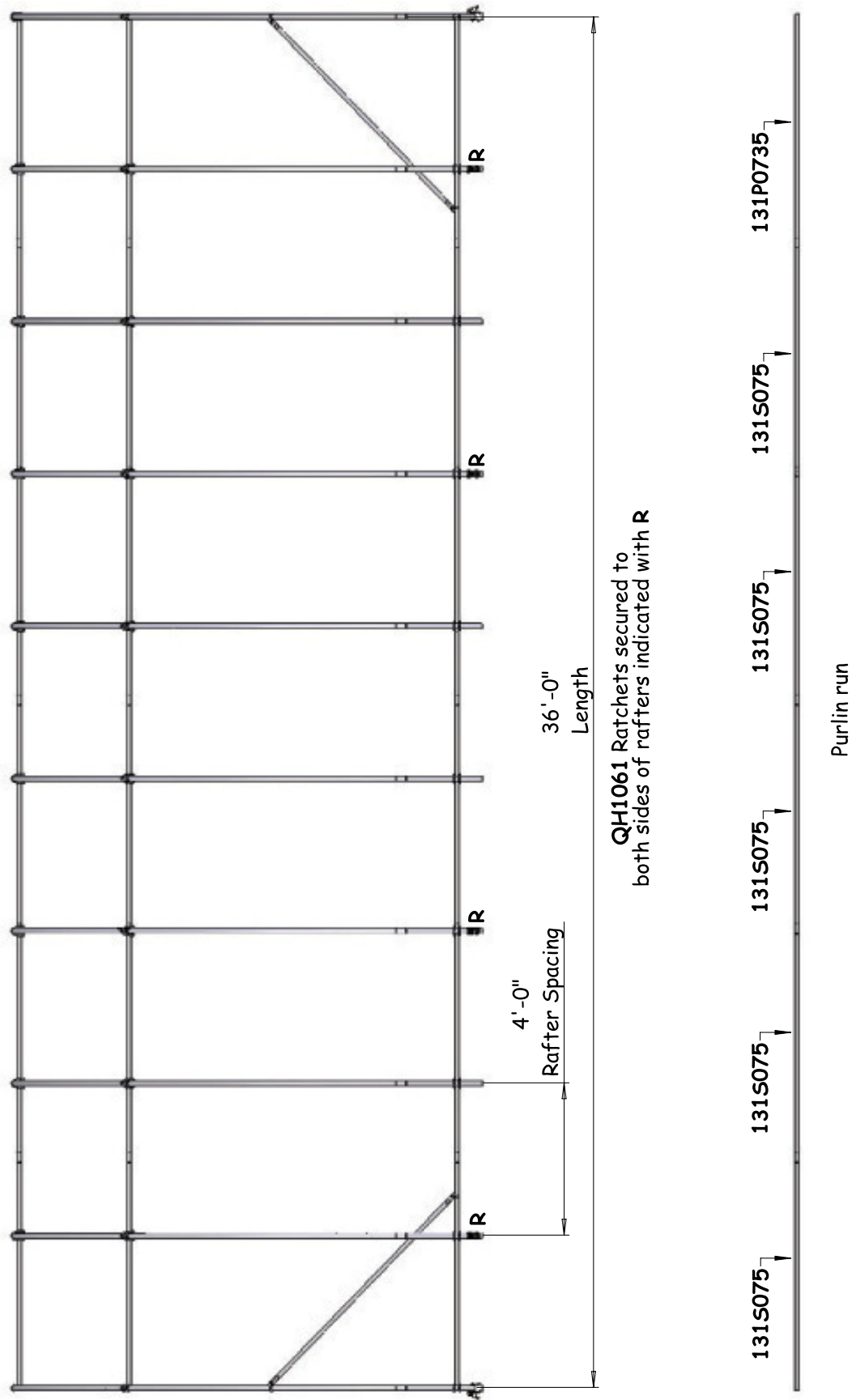

CONNECTIONS

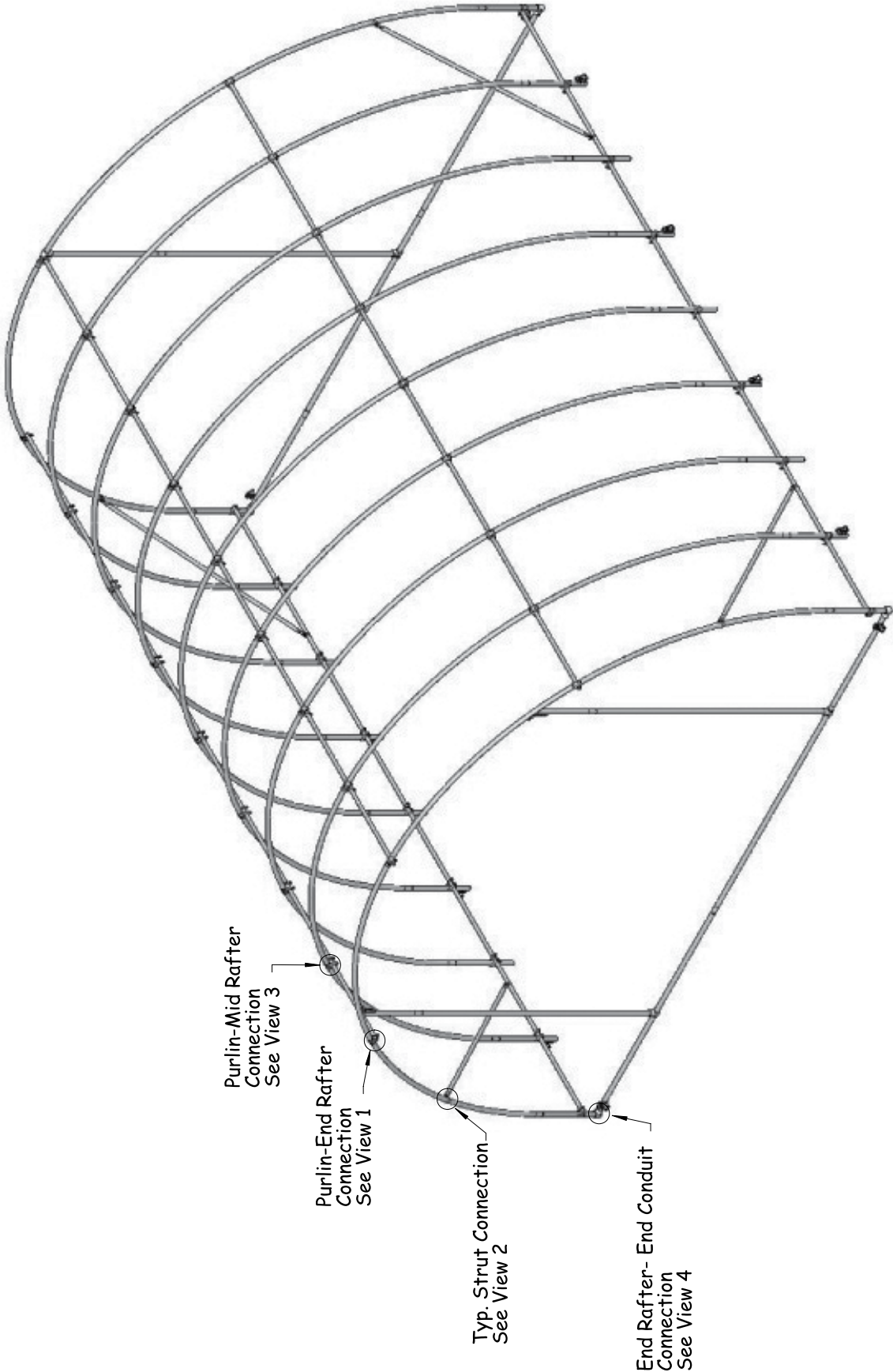

CONNECTION - DETAILS

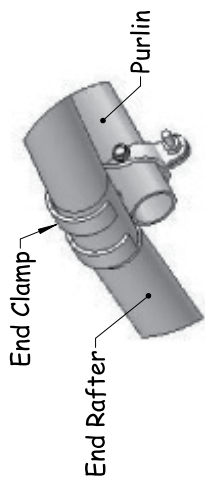

VIEW 1
PURLIN-END RAFTER

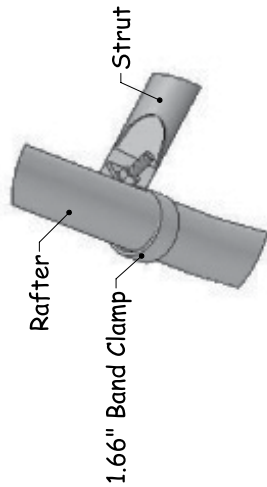

VIEW 2
STRUT CONNECTION

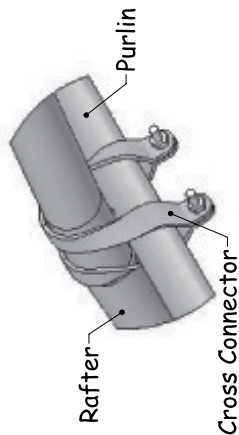

VIEW 3
PURLIN-MID RAFTER

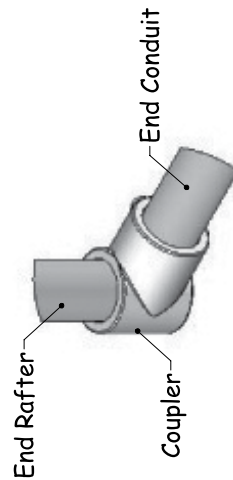

VIEW 4
END RAFTER-END CONDUIT

END FRAMING - FRONT

End Frame Detail Guide

- 1. View 1: End Framing-Rafter
- 2. View 2: QH1330 Bracket

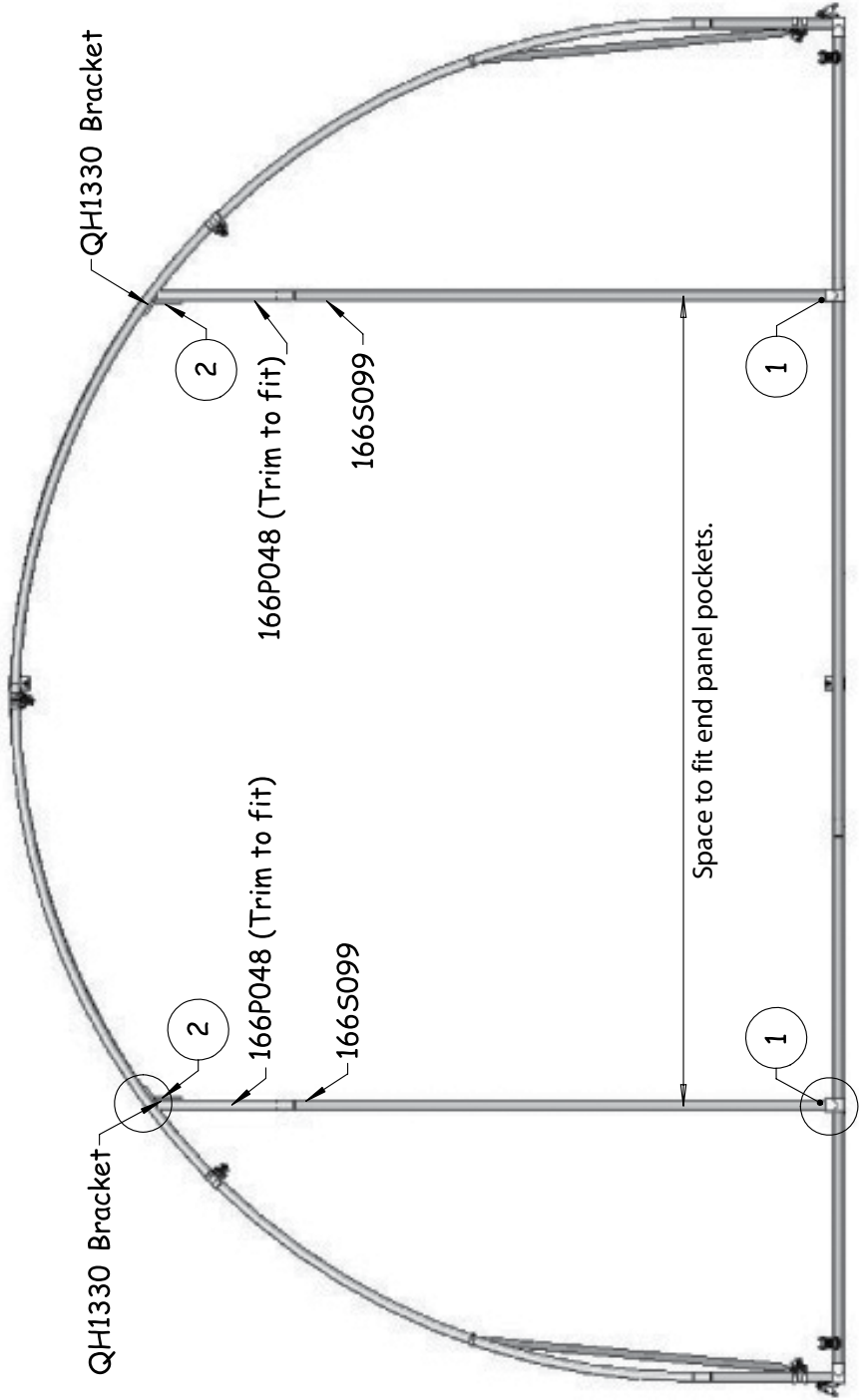

END FRAMING - BACK

End Frame Detail Guide

1. View 1: End Framing-Rafter

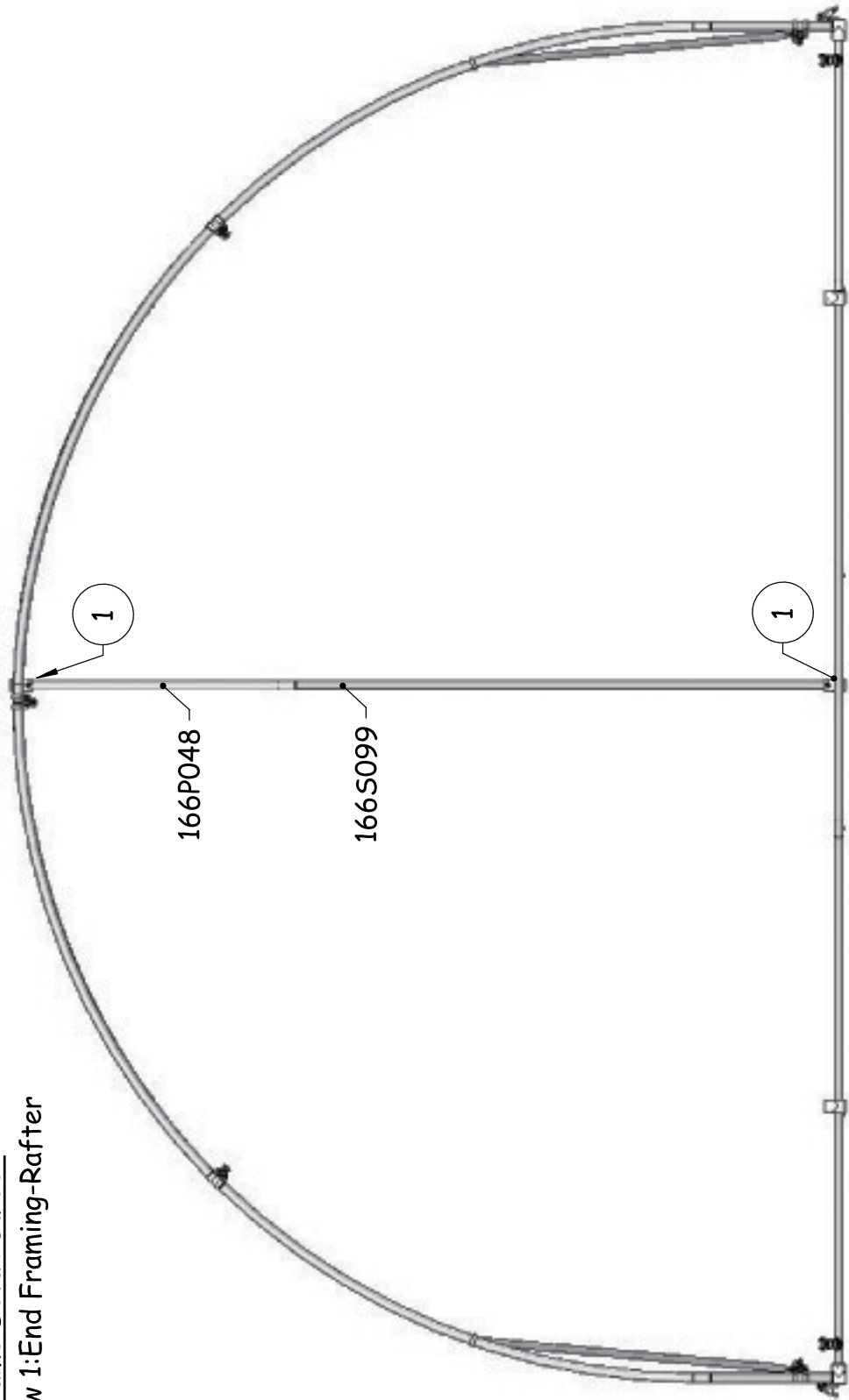

END FRAMING CONNECTIONS

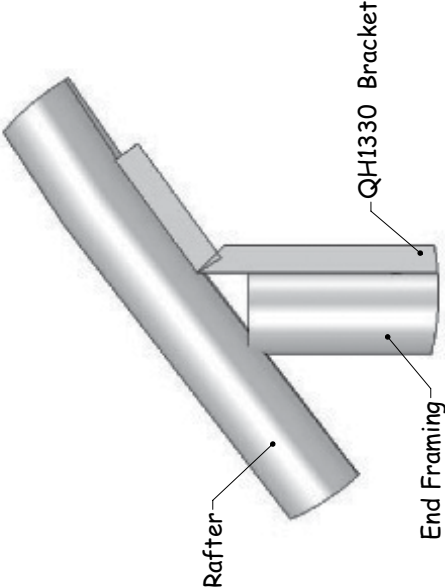

VIEW 2
QH1330 BRACKET

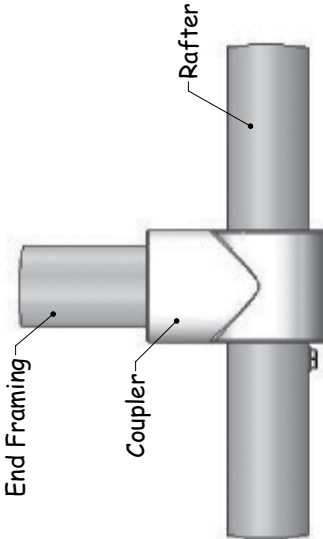

VIEW 1
END FRAMING - RAFTER