



ClearSpan™ Round Style One Car Garage



Photo may show a different but similar model.

©2008 ClearSpan™
All Rights Reserved. Reproduction
is prohibited without permission.



WARNING: Cancer and Reproductive Toxicity - P65Warnings.ca.gov

STK#
PB00300R5G

DIMENSIONS
12' W x 8' H x 20' L

Revision date: 12.01.08



YOU MUST READ THIS DOCUMENT BEFORE YOU BEGIN TO ASSEMBLE THE SHELTER.

Thank you for purchasing this ClearSpan™ shelter. When properly assembled and maintained, this product will provide years of reliable service. These instructions include helpful hints and important information needed to safely assemble and properly maintain the shelter. Please read these instructions **before** you begin.

If you have any questions during the assembly, contact Customer Service for assistance.

SAFETY PRECAUTIONS

- Wear eye protection.
- Wear head protection.
- Wear gloves when handling metal tubes.
- Use a portable GFCI (Ground Fault Circuit Interrupter) when working with power tools and cords.
- Do not climb on the shelter or framing during or after construction.
- Do not occupy the shelter during high winds, tornadoes, or hurricanes.
- Provide adequate ventilation if the structure is enclosed.
- Do not store hazardous materials in the shelter.
- Provide proper ingress and egress to prevent entrapment.

ANCHORING INSTRUCTIONS

Prior to assembling this shelter, please read the **MUST READ** document included with the shipment.

⚠ WARNING: The anchor assembly is an integral part of the shelter construction. Improper anchoring may cause shelter instability and failure of the structure. Failing to anchor the shelter properly *will void the manufacturer's warranty* and may cause serious injury and damage.

LOCATION

Choosing the proper location is an important step before you begin to assemble the structure.

The following suggestions and precautions will help you determine whether your selected location is the best location.

- Never erect the structure under power lines.
- Identify whether underground cables and pipes are present *before* preparing the site or anchoring the structure.
- Location should be away from structures that could cause snow to drift on or around the building.
- Do not position the shelter where large loads such as snow and ice, large tree branches, or other overhead obstacles could fall.

SITE

After choosing a location, proper preparation of the site is essential. Follow the information below.

- *A level site is required.* The site must be level to properly and safely erect and anchor the structure.
- For sites that are not concrete or gravel, placing wood blocks or other suitable supports under each rafter leg helps prevent the pipes from sinking or working into the site.
- Drainage: Water draining off the structure and from areas surrounding the site should drain away from the site to prevent damage to the site, the structure, and contents of the structure.

⚠ WARNING: The individuals assembling this structure are responsible for designing and furnishing all temporary bracing, shoring and support needed during the assembly process. For safety reasons, those who are not familiar with recognized construction methods and techniques must seek the help of a qualified contractor.

ASSEMBLY PROCEDURE

Following the instructions as presented will help ensure the proper assembly of your shelter. Failing to follow these steps may result in an improperly assembled and anchored shelter and will void all warranty and protection the owner is entitled.

The steps outlining the assembly process are as follows:

1. Verify that all parts are included in the shipment. Notify Customer Service for questions or concerns.
2. Read these instructions, the Must Read document, and all additional documentation included with the shipment **before** you begin assembling the shelter.
3. Gather the tools, bracing, ladders (and lifts), and assistance needed to assemble the shelter.
4. Check the weather **before** you install the roof cover and any panels (if equipped). Do not install covers or panels on a windy or stormy day.
5. Re-evaluate the location and site based on the information and precautions presented in the documentation included with the shipment.
6. Prepare the site (if applicable).
7. Assemble the frame components in the order they are presented in these instructions.
8. Assemble the frame including the struts (if equipped).
9. Consult the MUST READ document and properly anchor the assembled frame.
10. Install, tighten, and secure the end panel and main cover (if equipped). This applies to fabric covers that stretch over the frame assembly. Your shelter may include roof panels or side panels or both.
11. Read the Care and Maintenance information at the end of these instructions.

LIST OF WORDS AND PHRASES

Before you begin, it is important to become familiar with the words and phrases used in this instruction manual.

These words and phrases are common to most ClearSpan™ shelters and identify the different parts of the shelter. (Some are used in this document. Others may not apply to this particular shelter.) These terms describe the shipped parts and can also be found on the materials list/spec sheets included with the shipment. To aid in the assembly, read through the following definitions before you begin to assemble your shelter.

- **Conduit:** An assembly of pipes used to secure the main cover and end panels (if equipped). Purlins and some strut assemblies also consist of connected pipes to form a conduit. Each pipe joint of a conduit assembly is secured with a self-tapping Tek screw.
- **Coupler or Fitting:** A part of the frame assembly where legs, purlins and rafter pipes are inserted and secured. In most instances, 3-way and 4-way couplers are used. In some larger applications, couplers are used to secure the joints of the different rafter sections during the assembly of the rafters. Some shelters do not use couplers.
- **Foot or Rafter Foot:** The part attached to and found at the base of the rafter or leg of the shelter. Depending on the shelter, the foot is an optional purchase. Some shelters do not offer an optional foot. Some use 1-Way connectors.
- **Must Read Document:** This document includes building and shelter anchoring instructions, steps for end wall reinforcement, safety precautions, and notices and warnings. The Must Read document is sent with all shelters and buildings. If you did not receive a Must Read document, contact Customer Service to request one.
- **On-Center:** Term used to describe a measurement taken from the vertical center of the rafter or frame member to the vertical center of another.
- **Purlin:** The pipe assembly that runs perpendicular to the rafters or framework that supports the main cover. Purlins are found on the sides and roof areas of the assembled frame, are evenly spaced, and typically run from the front to the back of the shelter.
- **Plain or Straight Pipe:** A term used to describe a pipe that has the same diameter or width throughout its entire length.
- **Strut:** A strut is usually a length of pipe with two flattened ends and is used for diagonal bracing of the shelter frame. A strut is typically secured to the frame work by special brackets and bolts.
- **Swaged End or Swaged Pipe:** The term "swaged" refers to the tapered end of the pipe or tube. Swaged ends of a pipe can be inserted into couplers and the straight ends of other pipes.
- **Tek Screw:** A self-tapping fastener used to secure pipe joints and to fasten brackets to rafters.

CLEARSPAN™ GARAGES & STORAGE SHEDS

REQUIRED TOOLS

Space below is reserved for customer notes.

The following list identifies the main tools needed to assemble the shelter. Additional tools and supports may be needed depending on the structure, location, and application.

- Tape measure or measuring device
- Fine point marker to mark the location on tubing.
- Variable speed drill and impact driver (cordless with extra batteries works best)
- Wrench, ratchet and socket (recommended)
- 1/4" Allen wrench
- Scissors
- Two ropes long enough to reach over the shelter
- Hammers and gloves
- Metal file and Metal Cutting Saw
- Duct tape (supplied by customer)
- Box cutter or utility knife
- Ladders, work platforms, and other machinery for lifting designed to work safely at the height of the shelter

UNPACK AND IDENTIFY PARTS

The following steps will ensure that you have all the necessary parts before you begin to assemble the shelter.

1. Unpack the contents of the shipment and place where you can easily inventory the parts. Refer to the Bill of Materials/Spec Sheets.
2. Verify that all parts listed on the Bill of Materials/Spec Sheets are present. If anything is missing or you have questions, consult the Pictorial Parts Guide and all shelter diagrams for clarification, or contact Customer Service.

NOTE: At this time, you do not need to open the plastic bags containing smaller parts such as fasteners or washers.

QUICK START GUIDE

For a quick overview of this shelter and its components, consult the Quick Start Guide at the back of these instructions.

ClearSpan

The following graphics and photos will help you identify the different parts. (Some parts are not shown.)



QH1400
Band Clamp



10015106
T-Fitting



CC6212
Fabric Clip



FA4482B
Tek Screw



102855
End Clamp



102479
Cross Connector



QH1061
Ratchet

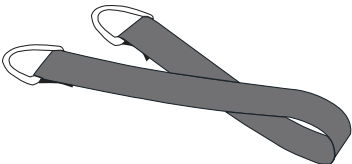

102947
D-ring Strap

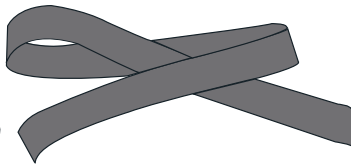

103620b
Plain End Strap

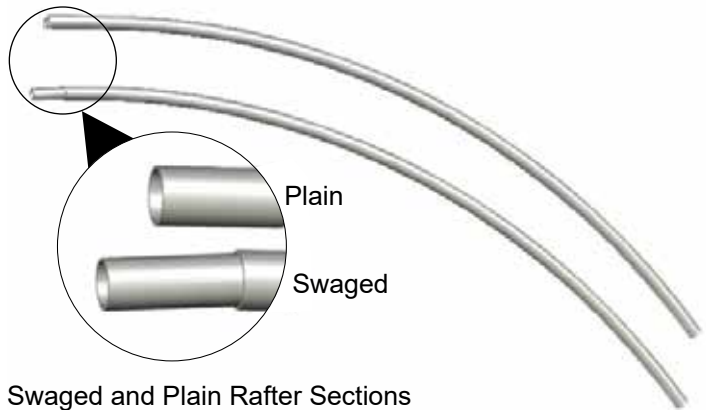

Swaged and Plain Rafter Sections

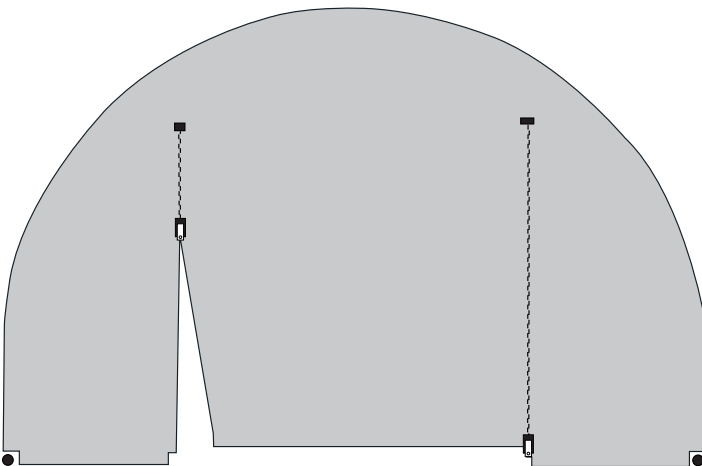

Zippered End Panel

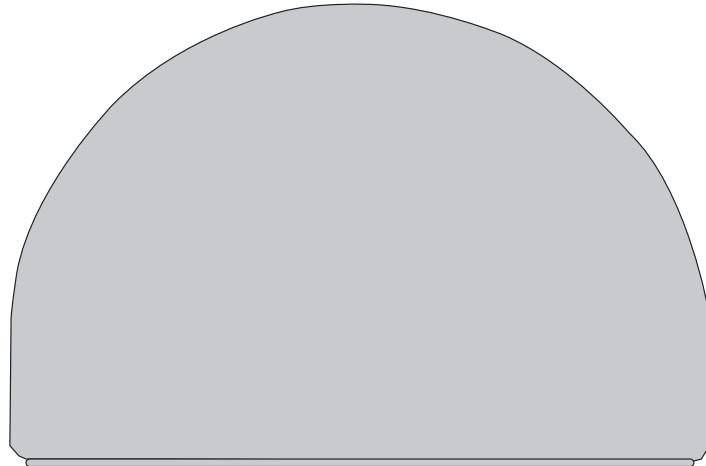

Plain End Panel



Round Style Mini Garage

OVERVIEW

This section is an overview of the process for assembling your Round Style Mini Garage. For details, please see section, Assembling the Round Style Mini Garage Components. See illustration below to identify main parts of shelter.

1. Locate the required parts for each assembly procedure.
2. Assemble the rafters and frame, and square frame.
3. Prepare end panels and insert end conduits.
4. Connect end conduits and anchor the shelter.
5. Attach end panels and prepare and attach main cover.

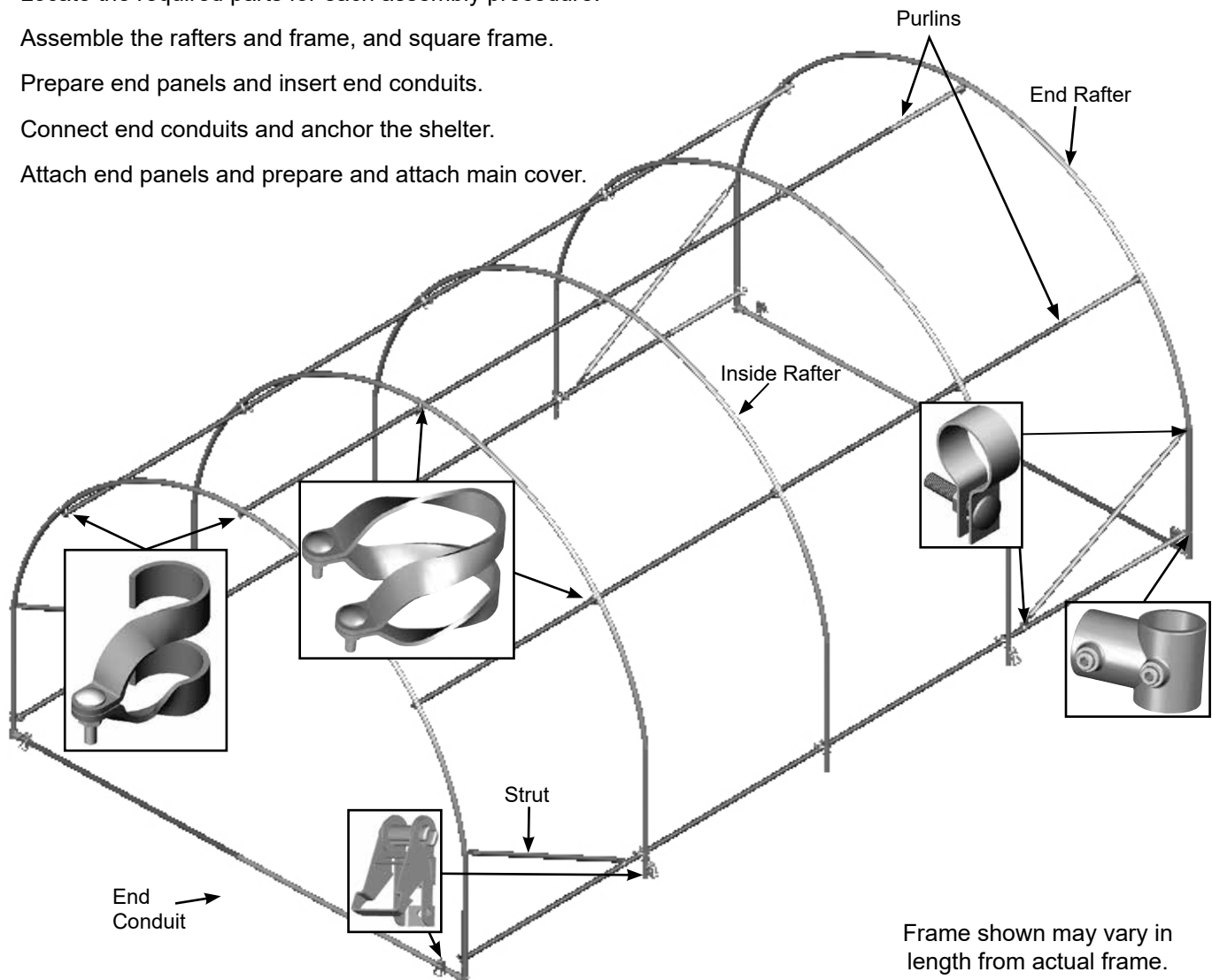

LAY OUT THE BUILDING SITE

After the site is prepared, identify the location of the shelter corners helps to square the frame after it is assembled.

Taking these steps **before** assembling the shelter saves time and ensures that the structure is positioned as desired. The following procedure is a suggested method. Its use depends on the size of the shelter, shelter application, the footings, and the method used to anchor the shelter.

SQUARE THE SITE

1. Identify a corner where a building rafter will be positioned, drive in a stake, and string a line the exact width of the building and stake in place.
2. String a line at least as long as the building from the first stake at 90°.

NOTE: A transit can be used to ensure an accurate 90° angle, or the 3-4-5 rule can be used. Refer to diagram. Using multiples of 3-4-5 such as 6-8-10 or 12-16-20 helps to maintain an accurate 90° angle.

3. After squaring the position of the building and placing a stake at all corners, string a line between the stakes to mark the base of the building.

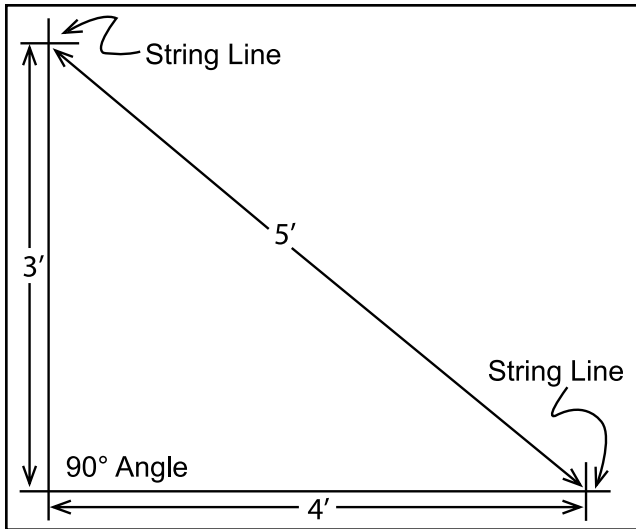

ASSEMBLING THE ROUND STYLE MINI GARAGE COMPONENTS

NOTE: Assistance is required to assemble the mini garage.

RAFTER ASSEMBLY

Gather the Parts:

- Rafter Position #1 (Pipe #12R1301)
- Rafter Position #2 (Pipe #12R1302)
- Rafter Position #3 (Pipe #12R1303)
- Purlin End Clamps
- Band Clamps
- Tek Screws
- Nut Setter 3/8" x 2-9/16 Magnetic

Rafter Assembly Procedure:

Each rafter assembly consists of four (4) rafter sections: two (2) curved rafter pipes (for the top) and two (2) side pipes that connect to the upper center pipes.

1. Select the four (4) pipes needed to assemble a rafter and arrange these on a flat surface as shown below for assembly.

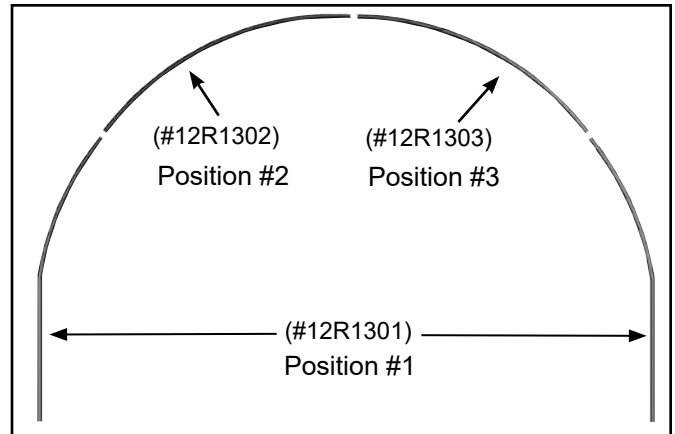

2. Slide the swaged portion of each rafter pipe into the plain end of the pipe as shown.

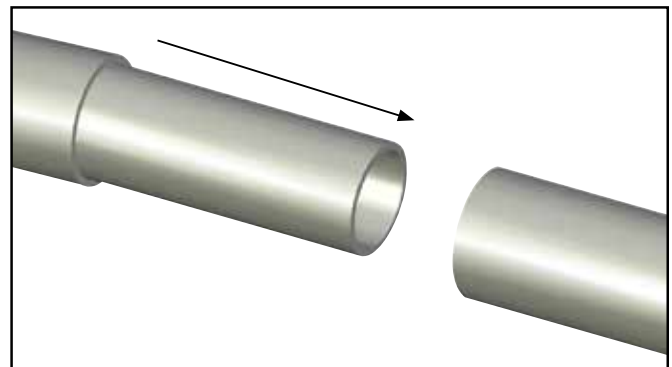

CLEARSPAN™ GARAGES & STORAGE SHEDS

RAFTER ASSEMBLY (CONTINUED)

3. With the main rafter pipes seated at each joint and the rafter positioned on a flat surface, secure each joint with a single self-tapping Tek screw. Position Tek screw approximately 1" from pipe joint.

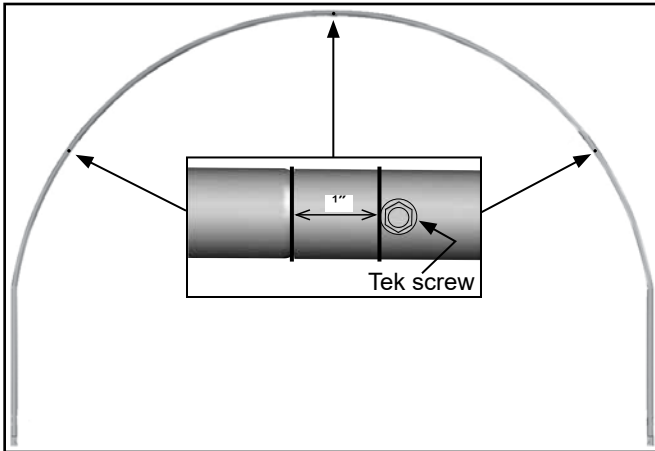

ATTENTION: Install the screws so they will not touch the cover once it is installed. This is typically on the backside of the rafter, which will be the surface visible from the *inside* of the shelter once the frame is assembled.

4. Assemble rafters as described and continue with the additional steps to complete the assembly of the two end rafters.

END RAFTER ASSEMBLY

In addition to the steps in the previous procedure, complete the following steps *for the two end rafters only*.

1. Take one of the assembled rafters and place it on a flat surface.
2. Slide five (5) end clamps and two (2) band clamps onto the rafter in the locations noted below. (Do not secure the clamps to the rafter at this time. These clamps will be repositioned during the frame assembly when the purlins are added.)

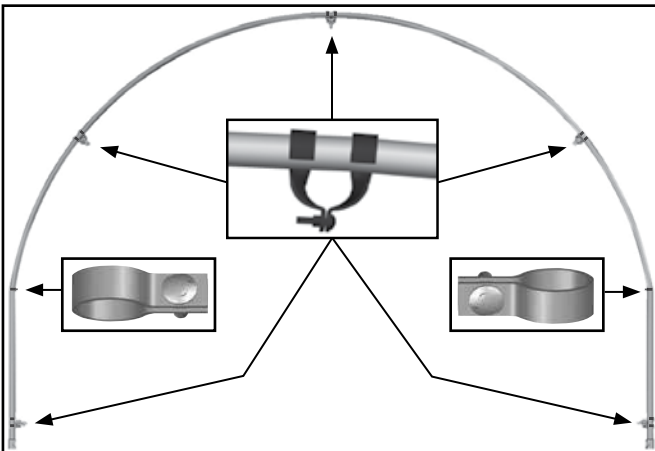

NOTE: All clamps must be positioned as shown. Use a piece of duct tape to keep the clamps from sliding when the rafter is set in place.

View of the end rafter and clamps as shown from the *outside* when the frame is assembled.

3. Repeat the same procedure for the final end rafter.
4. Continue with the FRAME ASSEMBLY instructions that follow.

FRAME ASSEMBLY

Gather the Parts

- All Rafter Assemblies
- Pipe 1.315" x 75" Swaged
- Pipe 1.315" x 25.5" Plain
- Strut 5'
- Band Clamps

Frame Assembly Procedure:

1. Stand one end rafter (one with the end clamps attached) and brace it in place as shown below. Check that the rafter is standing up straight (plumb). Position the bolt side of end clamp to the inside of the frame.

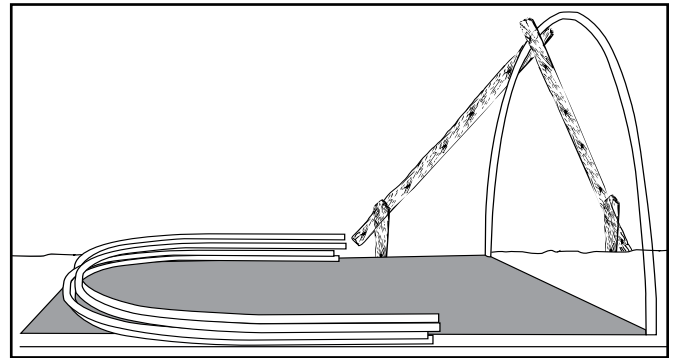

2. Insert the plain end of one 75" purlin pipe into each end clamp at the bottom of the end rafter.

CAUTION: To prevent cover damage, the ends of the purlins should extend no more than 1/2" past the end clamp. The bolt side of the end clamps must go toward the "inside" of the shelter (the same side as the purlin) as shown below.

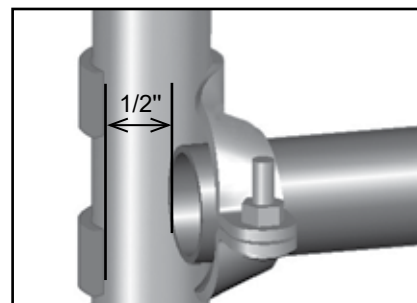

FRAME ASSEMBLY (CONTINUED)

3. Slide a band clamp on each of the two bottom purlins between the first and second rafters. Make sure the heads of the band clamp bolts are toward the outside of the shelter.
4. Position an inside rafter from the end rafter using an on-center, rafter-to-rafter spacing of 60". (Another person is required to hold the rafter in position.)

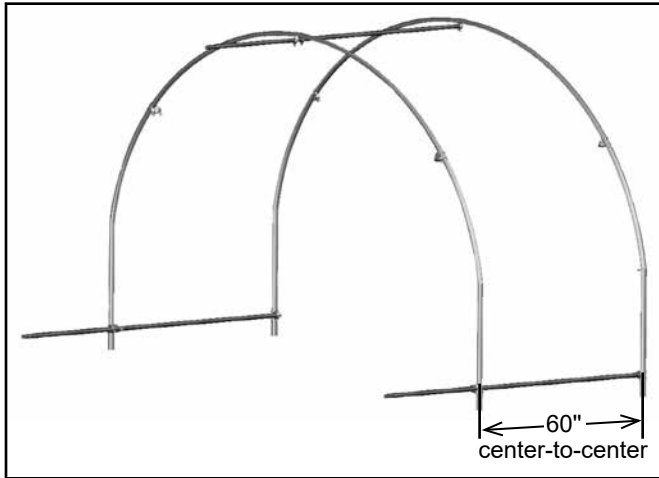

5. Install a cross connector and insert the purlin pipe through the connector at the top of the interior rafter and also through the end clamp at the top of the end rafter.
6. Verify that both rafters are plumb and properly spaced (60" on center).
7. Tighten the cross connector at the top of the interior rafter and tighten the end clamp at the top of the end rafter.

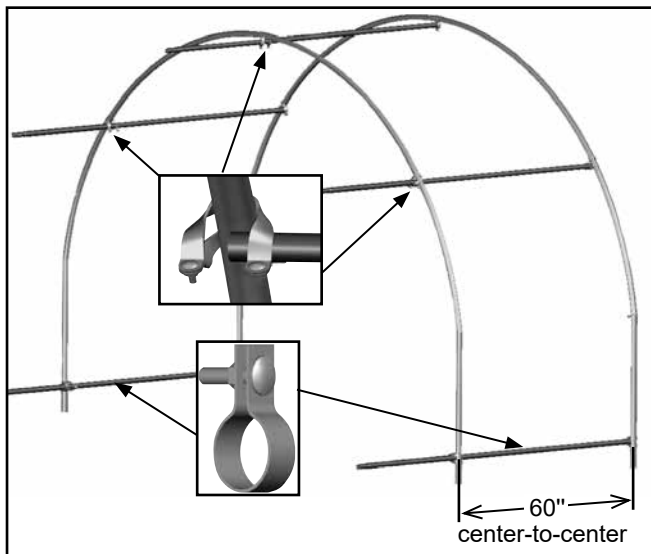

8. Move to the lower end of the rafters and position the purlin 4-6" up from the finished grade.

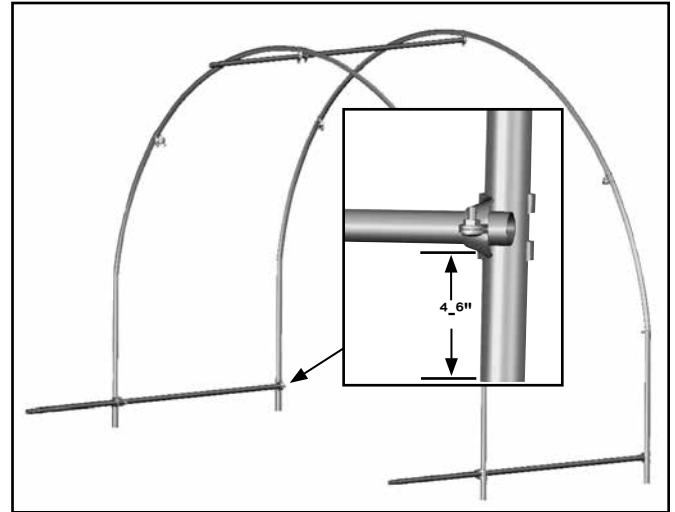

9. Install the remaining purlins. Verify the rafter spacing is 60" on-center and tighten connectors.

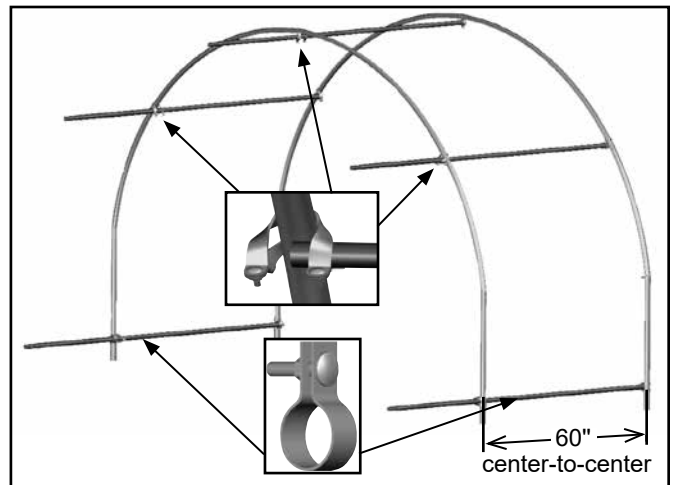

10. Continue adding rafters and purlins until the frame is assembled. Each purlin consists of three (3) 75" swaged pipes and one (1) 25.5" plain pipe.

NOTE: Remember to slide a band clamp onto each bottom purlin between the first and second rafters at the remaining end of the shelter.

CLEARSPAN™ GARAGES & STORAGE SHEDS

FRAME ASSEMBLY (CONTINUED)

11. Finish each purlin with a 25.5" pipe and use the final end rafter to complete the assembly.

NOTE: To prevent cover damage, DO NOT allow the purlin to extend beyond the end rafter.

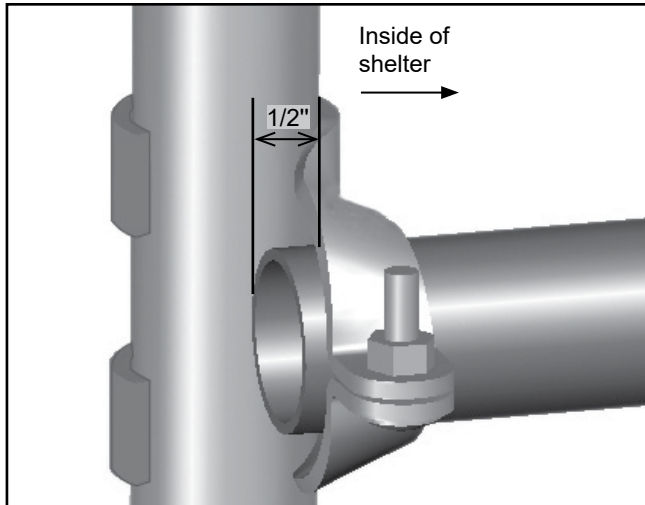

CAUTION: To prevent cover damage, the ends of the purlins should extend no more than 1/2" past the end clamp. The bolt side of the end clamps must go toward the "inside" of the shelter (the same side as the purlin) as shown.

12. Return to each clamp and install a Tek screw through the clamp and into the purlin pipe as shown.
13. Secure each clamp to the rafter using a Tek screw.

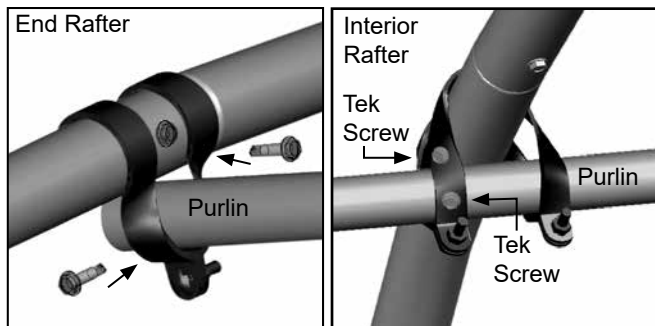

Strut Assembly Procedure

1. After the rafter assembly is complete, verify that the band clamps are in the proper location. See diagram below.

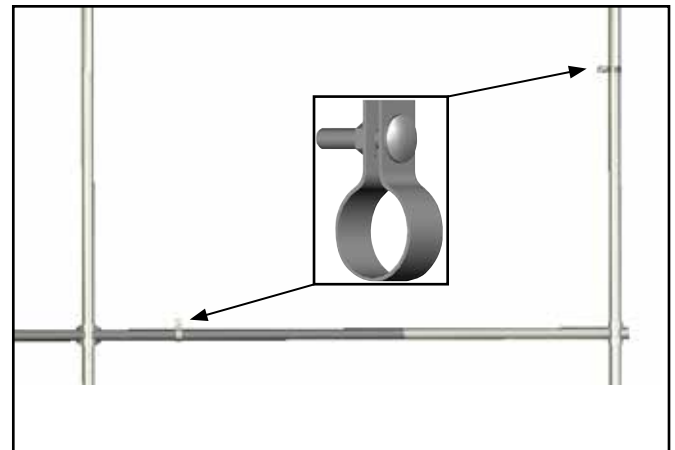

2. Remove the bolts and attach a strut between the band clamp on the purlin and the band clamp on the end rafter. Position the strut so that it forms a triangle as shown below.

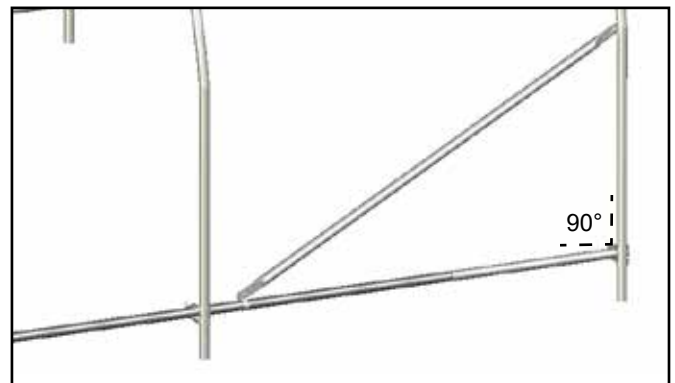

NOTE: Verify that the bolt heads are to the outside of the shelter and that the end rafter is plumb before tightening the nuts.

3. Install the remaining struts and tighten all band clamp bolts.
4. Secure each band clamp to each purlin or rafter with a Tek screw.
5. Return to each purlin joint and secure using a Tek screw.

SQUARE THE ASSEMBLED FRAME

Gather the Parts

- Measuring tape
- Tek Screws

Complete these steps:

1. Square the frame by measuring diagonally corner-to-corner, and align all rafters as shown below.
2. Verify that the width of each rafter is 12' center-to-center, and the length of the frame is 20'.

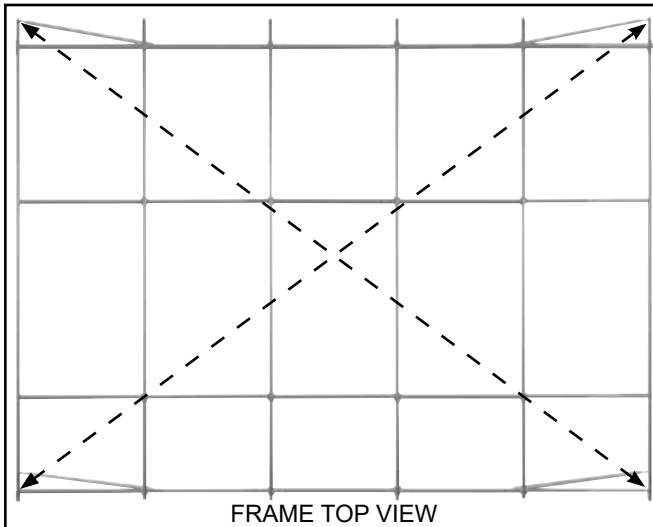

NOTE: The frame is square when the two diagonal measurements are the same.

FINISH ROUGH EDGES

Gather the Parts

- Duct tape (supplied by customer)
 - Metal file (may not be needed)
1. Check for any sharp edges on the frame and file them smooth so they will not cut the cover.
 2. Apply two layers of heavy duct tape on all pipe connections and clamps that may contact the cover.

END CONDUITS ASSEMBLY

Gather the Parts:

- Pipe 1.315" x 73.5" Plain (2)
- Pipe 1.315" x 75" Swaged (2)
- T-fittings
- Duct tape (supplied by customer)
- Metal Cutting Saw
- Tek Screws

Assembly Procedure:

1. Each end conduit consists of one (1) 73.5" pipe, one (1) 75" pipe, and two (2) T-fittings. Two (2) end conduits are required.
2. Assemble an end conduit by connecting a 75" swaged pipe to a 73.5" plain pipe and secure the joint using a Tek screw. Apply duct tape over the Tek screw and pipe joint to protect the end panel.

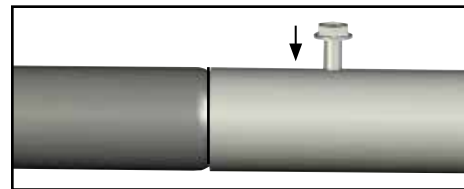

3. Cut the conduit to 142 3/4" overall length.
4. Repeat assembly for the remaining end conduit.
5. Add the T-fittings at the ends of the conduits.

NOTE: Do not insert the end conduit pipes all the way into the T-fittings, but instead allow room for the end rafter to be inserted later.

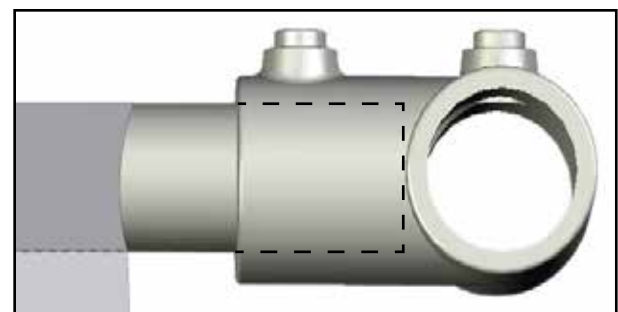
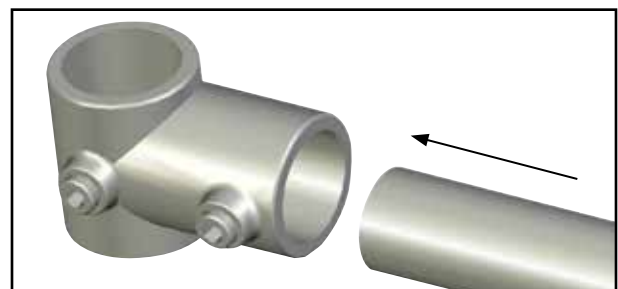

CLEARSPAN™ GARAGES & STORAGE SHEDS

PREPARE END PANELS

⚠ CAUTION: To prevent damage, do not install end panels on a windy day.

Gather the Parts:

- End Panel Solid (Plain)
- End Panel Zippered (Door)
- End Conduit Assemblies (2)
- Scissors

Assembly Procedure:

1. If the corners of the end panels have not been cut out, follow this procedure:
 - a. Place an end panel out on a clean flat surface.
 - b. Position the end conduit assembly centered side-to-side on top of the hem.
 - c. With scissors, trim the corner of the end panel on the dotted line shown below so the T-fitting is exposed when conduit is placed inside the hem.
 - d. Repeat the same steps for the other end of this end panel and for both ends of the remaining end panel.

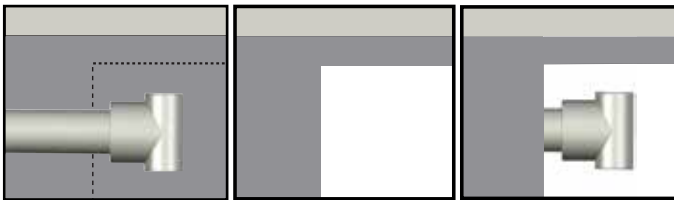

2. Remove one T-fitting from the end conduit assembly and slide the end conduit assembly into the hem at the bottom of the solid (plain) end panel. Replace the T-fitting that was removed.
3. On the zippered end panel, insert the end conduit through the two side panels of the end panel (as shown below) and not through the door section.

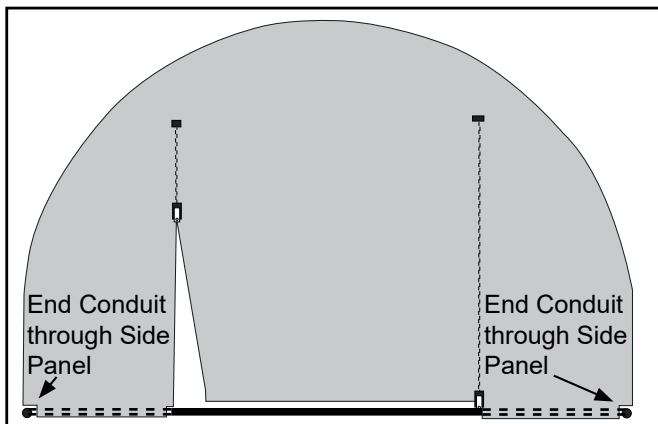

ANCHOR THE SHELTER

At this point, anchor the shelter. Consult the MUST READ document for anchoring information and suggestions. Please call customer service at 1-800-245-9881 for additional anchoring information.

⚠ CAUTION: The anchor assembly is an integral part of the shelter construction. Improper anchoring may cause shelter instability and failure of the structure to perform as designed. Failing to anchor the shelter properly will void the manufacturer's warranty and may cause serious injury and damage.

ATTACH END CONDUIT ASSEMBLIES

1. Verify the end conduits of end panels are inserted into the T-fittings correctly.

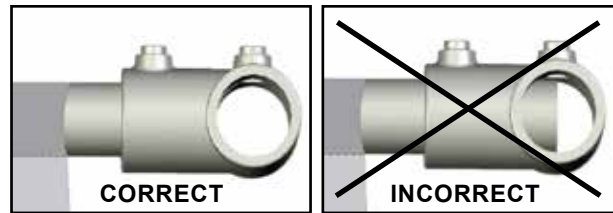

ATTENTION: Do not allow the end conduit to extend into the opening that remains for the bottom of the end rafters.

2. Insert the the end rafters into the T-fitting of the end conduit.
3. Verify that the rafter pipe is flush with the bottom of the T-fitting.
4. Tighten the Allen screws to secure the T-fitting to the end rafter and end conduit.

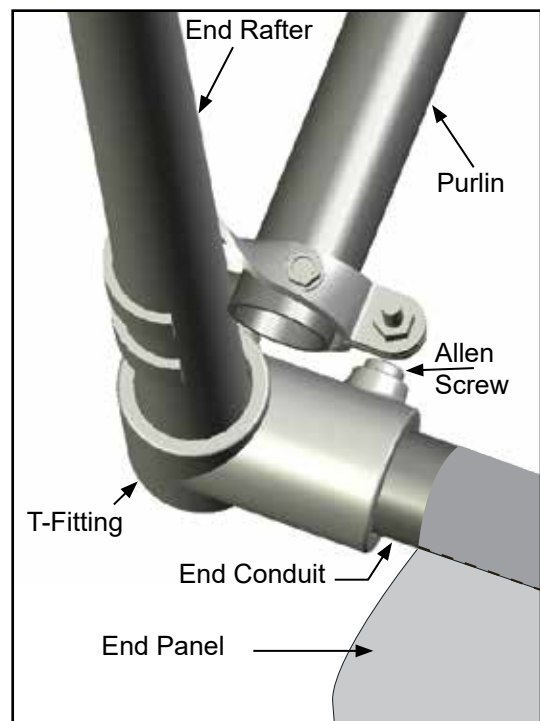

ATTACH END PANEL ASSEMBLIES

Gather the Parts:

- End Panel Assemblies
- Fabric Clips (Divide quantity in half.)
- Tek Screws
- Measuring Tape
- Scissors

Assembly Procedure:

1. While standing inside the shelter, start at the peak of the end rafter and pull the solid (plain) end panel over the top of the rafter so the material edge is on the inside of the rafter.
2. Secure the solid end panel in place at the top center of end rafter with a fabric clip and Tek screw.
3. Moving outward in both directions, place fabric clips spaced evenly on rafter.
4. Secure each fabric clip to the end rafter with a Tek screw (on the inside where it will not contact the cover).

NOTE: The end panels may be shipped as untrimmed rectangular pieces. If so, use scissors to trim the excess end panel material inside the shelter about an inch or two past the fabric clip as shown below.



5. Secure the zippered end panel in place using fabric clips with Tek screws as completed on the plain end panel.

PREPARE MAIN COVER

Gather the Parts:

- Ratchet (1" 4000lb)
- Pipe 1.315" x 75" Swaged
- Pipe 1.315" x 25.5" Plain
- Cover
- Tek Screws

Assembly Procedure:

The main cover is attached to one side of the shelter using D-ring straps. It is stretched and secured to the remaining side with plain end straps and ratchets.

The ends (front and back) of the main cover are secured to the bottom of each end panel corner with a ratchet attached to the end panel conduit. The straps to secure the ends of the main cover come pre-installed.

NOTE: When handling the main cover and setting it in position, do not pull on the end straps. They will pull out of the cover.

⚠ WARNING: To prevent damage to the cover and to prevent serious personal injury, DO NOT attempt to install the main cover on windy days.

1. Fasten a ratchet to the end conduit with a Tek screw in the bottom hole of the ratchet as shown below. The ratchet should be about 6" in from the end of the conduit. Repeat this step in all four corners.

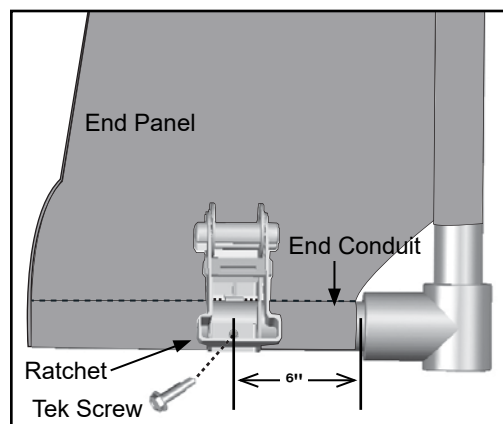

2. Assemble two main cover conduits. Start each conduit assembly with one 25.5" plain pipe and add three 75" swaged pipes to arrive at the correct length. Secure each pipe joint with a Tek screw and wrap the joint with duct tape.

These cover conduits are inserted into the pockets sewn into the main cover. The conduits are used to tighten and secure the main cover.

CLEARSPAN™ GARAGES & STORAGE SHEDS

PREPARE MAIN COVER (CONTINUED)

3. After assembling the cover conduits, locate the main cover and unfold it on a clean, smooth surface near the frame.

NOTE: Unfold the main cover with the inside surface facing up.

4. Locate the cover ends with strapping and align with the front and back of the shelter.
5. Insert the cover conduits into the pockets of the main cover.

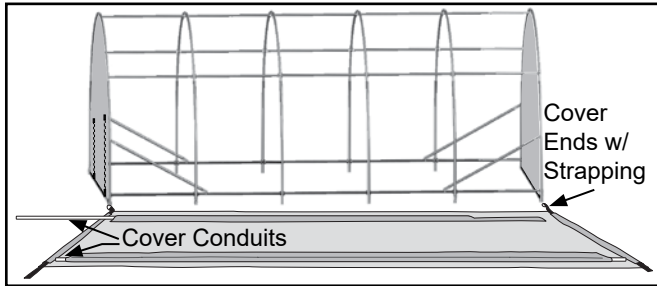

NOTE: Shelter shown above may be a different length than this model.

ATTACH MAIN COVER

Gather the Parts:

- Main cover (with conduits already inserted)
- Ropes long enough to reach over the frame (provided by customer)
- D-Ring Straps and Plain Straps
- Tek screws and Fender washers
- Box cutter or utility knife

Assembly Procedure:

1. To pull the cover over the frame, attach a rope to each end of the cover conduit. Wrap the rope around the conduit a few times to prevent it from slipping off.

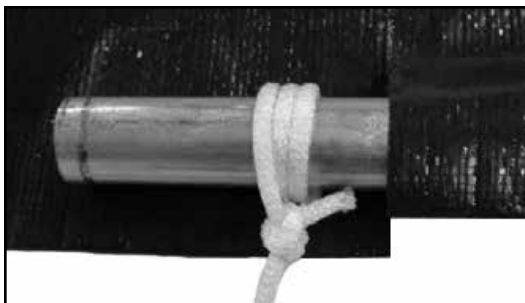

NOTE: Depending on the length of the cover it may be necessary to attach additional ropes to the cover conduit between the end ropes by cutting a small opening in the cover pocket and tying the rope around the conduit. **DO NOT** cut through the main cover. *Cut through the conduit pocket only.*

2. With all ropes attached to the cover conduit, lift the conduit and carry the cover toward the base of the frame.
3. Toss the ropes over the frame and pull the cover into position. One person is required at each rope.

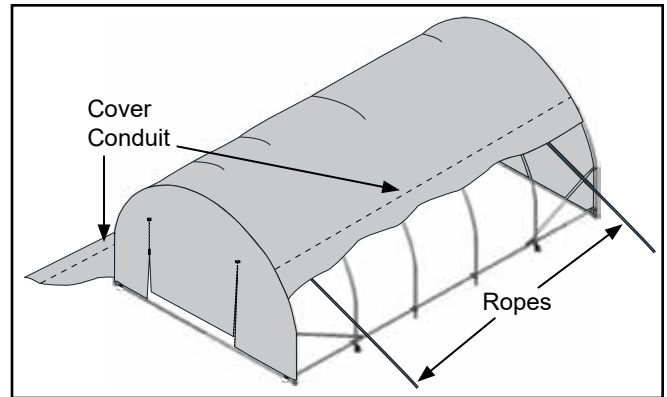

4. Once the main cover is pulled into position, center the cover on the frame and remove the ropes. Loosely secure the ends of the cover to the ratchets attached to the front and back end panel conduits.

ATTENTION: Do not tighten the straps at this time

5. Place the D-ring straps on the ground along one side of the shelter beside the rafters identified by the arrows below. Place the plain straps and ratchets *on the opposite side of the shelter* at the same rafters as the D-ring straps.

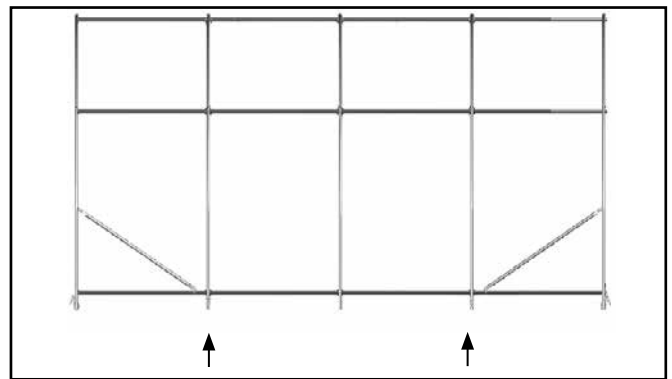

6. On the side of the shelter where the D-ring straps are located, lift the main cover skirt and cut a slit through the main cover pocket at the rafters identified by the arrows above.

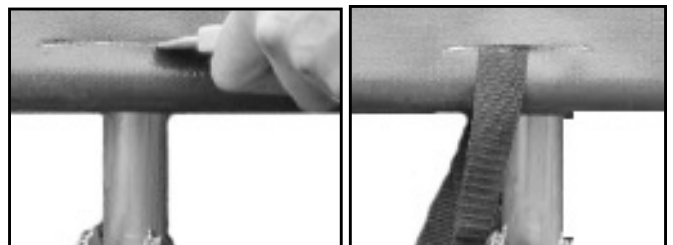

NOTE: **DO NOT** cut through the main cover. *Cut through the conduit pocket only.*

ATTACH MAIN COVER (CONTINUED)

7. Thread the D-ring strap through the slit in the cover pocket, wrap it around the cover conduit, and attach the strap assembly to the rafter with a Tek screw and fender washer.

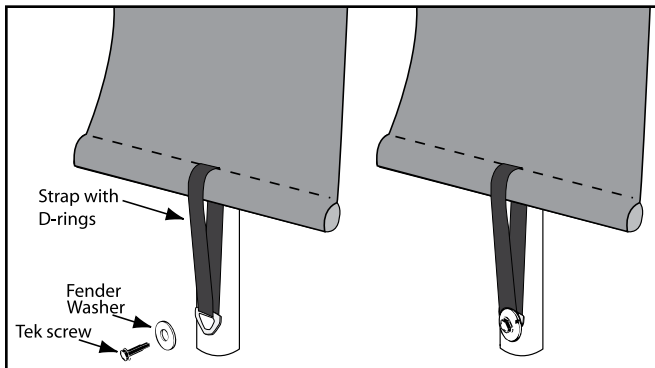

NOTE: Verify that the cover is centered side-to-side before attaching the D-ring strap.

8. Repeat the steps for the remaining D-ring strap.

NOTE: D-ring straps are attached to one side of the shelter. Ratchets are attached directly across from the D-ring straps on the *same rafter assembly*.

9. Move to the other side of the shelter and attach the ratchets to the rafters. Use the cover conduit as a guide to attach the ratchets to the rafters at the proper height. Fasten ratchets to the outside of these rafters using a Tek screw.

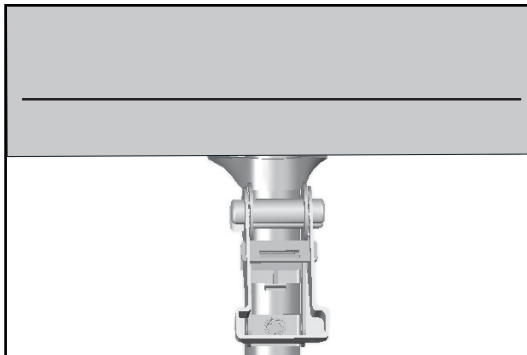

NOTE: DO NOT cut through the main cover. *Cut through the conduit pocket only.*

10. As previously described, make a slit in the cover conduit pocket and insert a 3' section of strap through the slit and around the cover conduit.

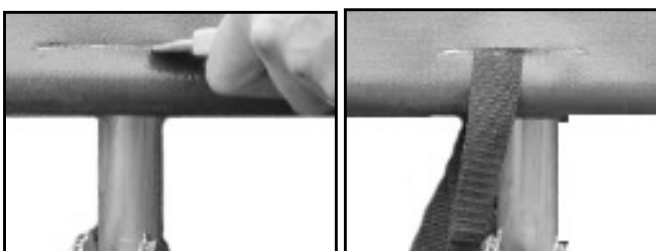

11. Thread the strap ends into the ratchet and slightly tighten.

NOTE: It may be necessary to remove excess strap if it binds up in the ratchet.

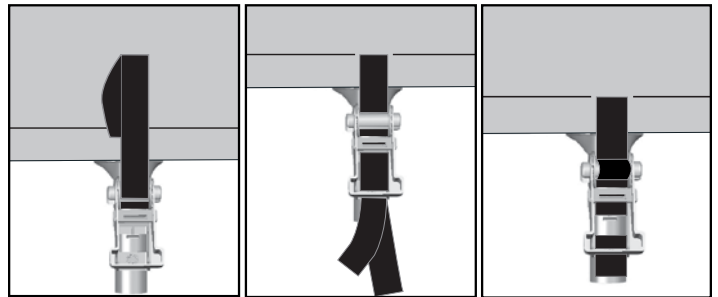

12. Repeat the steps for the remaining ratchet or ratchets.
13. Using additional help (if needed) tighten the main cover beginning with the ratchets along the side of the shelter frame.
14. After the side ratchets are tightened, return to the front and back end wall ratchets and tighten.

NOTE: Loosen the ratchets if needed to remove excess strap and tighten. If the main cover is not centered as desired, the D-ring straps can be repositioned (higher or lower) as needed and the main cover retightened.

15. Fold the skirt of main cover down and over the ratchets and D-ring straps to complete the installation of the main cover.

CLEARSPAN™ GARAGES & STORAGE SHEDS

SHELTER CARE AND MAINTENANCE

Space below is reserved for customer notes.

Proper care and maintenance of your shelter is important. Check the following items periodically to properly maintain your shelter:

- Regularly check the main cover and panels (if equipped) to see that these remain tight and in proper repair.
- Check connections and all fasteners to verify that they remain tight.
- Do not climb or stand on the shelter at anytime.
- Remove debris and objects that may accumulate on the shelter. Use tools that will not damage the cover when removing debris.
- Remove snow to prevent excess accumulation. Use tools that will not damage the cover when removing snow.
- Check the contents of the shelter to verify that nothing is touching the cover or the side panels that could cause damage.
- Check the anchoring system to ensure that all components are tight and in good repair.
- If the shelter is moved, inspect all parts and connections before reassembling.
- For replacement or missing parts, call 1-800-245-9881 for assistance.

NOTE: With the exception of Truss Arch buildings, ClearSpan™ shelters and greenhouses do not have any tested loading criteria.



QUICK START GUIDE

12' Wide Round Style One Car Garage

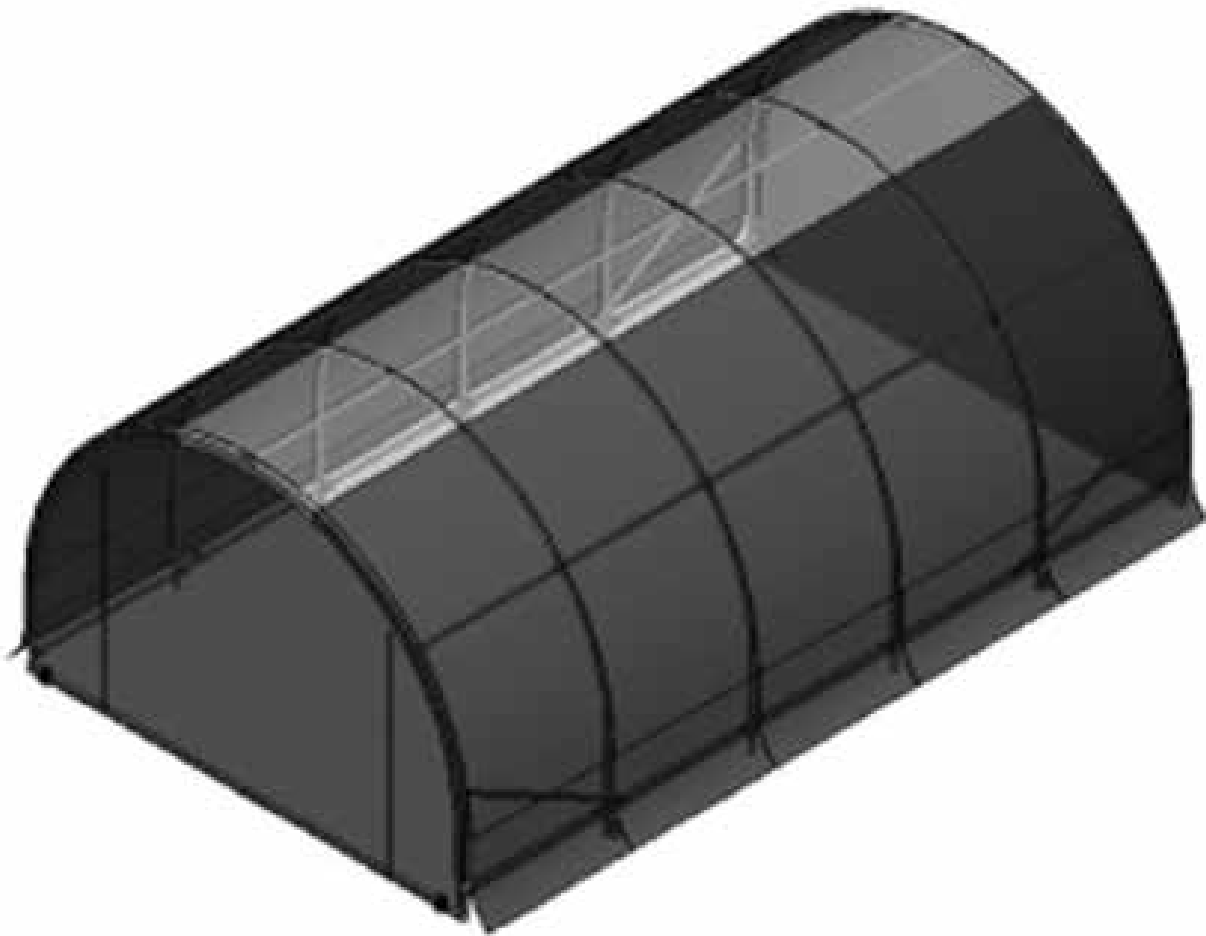

Frame shown may vary in length from actual frame.

FRONT PROFILE

Connection Note

Purlin connected to end rafters using 102855 clamp - See View 1

Purlin connected to mid rafters using 102479 cross connector - See View 3

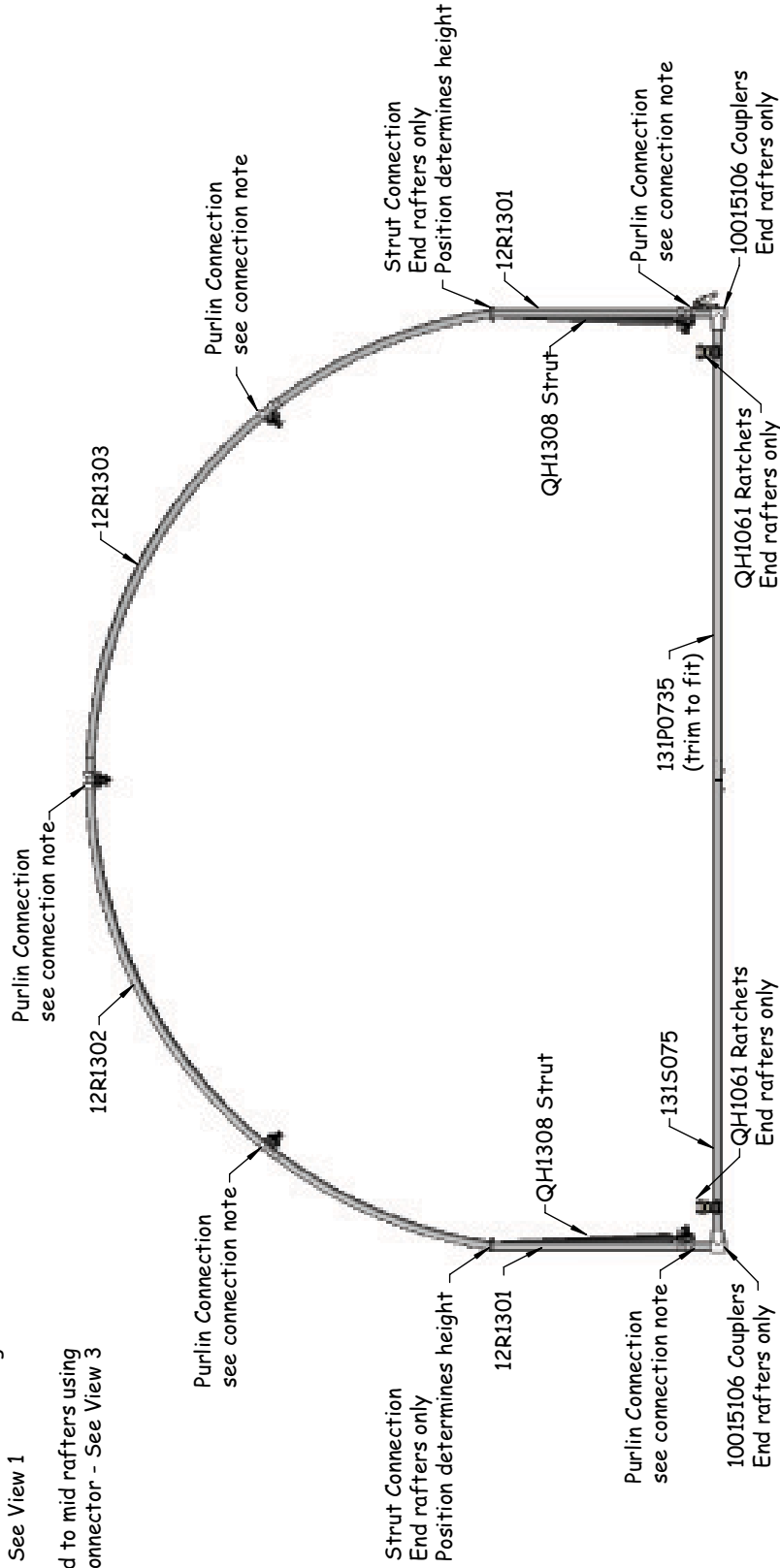

NOTE: End conduit only installed on End rafters

SIDE PROFILE

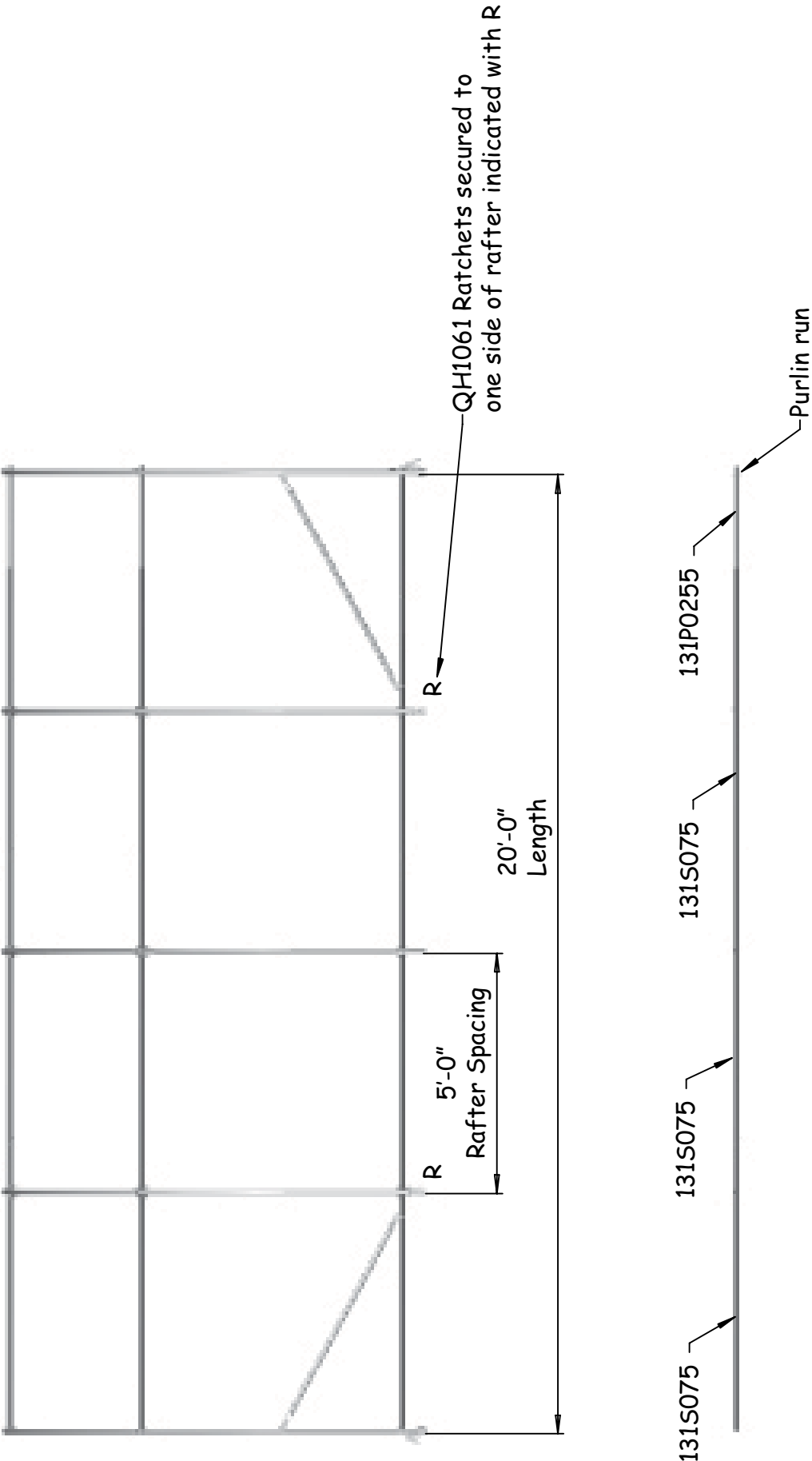

CONNECTIONS

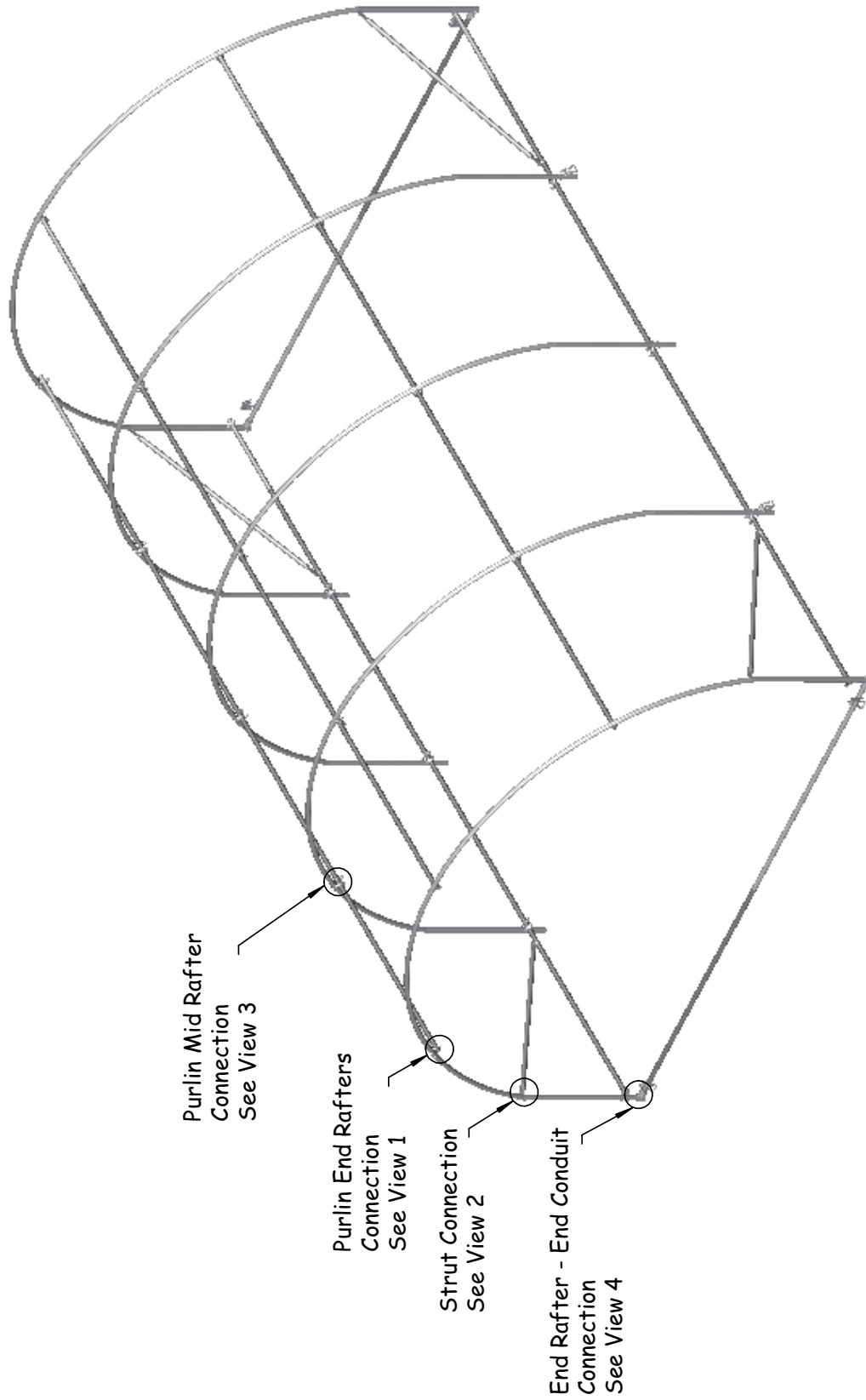

Frame shown may vary in length from actual frame.

CONNECTION - DETAILS

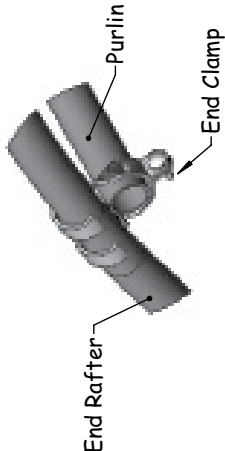

VIEW 1
PURLIN-END RAFTERS

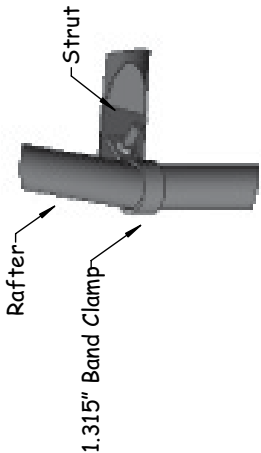

VIEW 2
STRUT CONNECTION

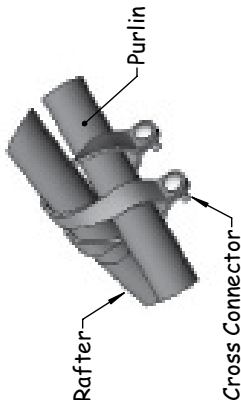

VIEW 3
PURLIN-MID RAFTER

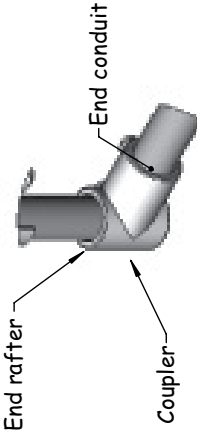

VIEW 4
END RAFTER - END CONDUIT