



ClearSpan™ Pro Solar Star™ Greenhouse Door Kits (Double Sliding Door)

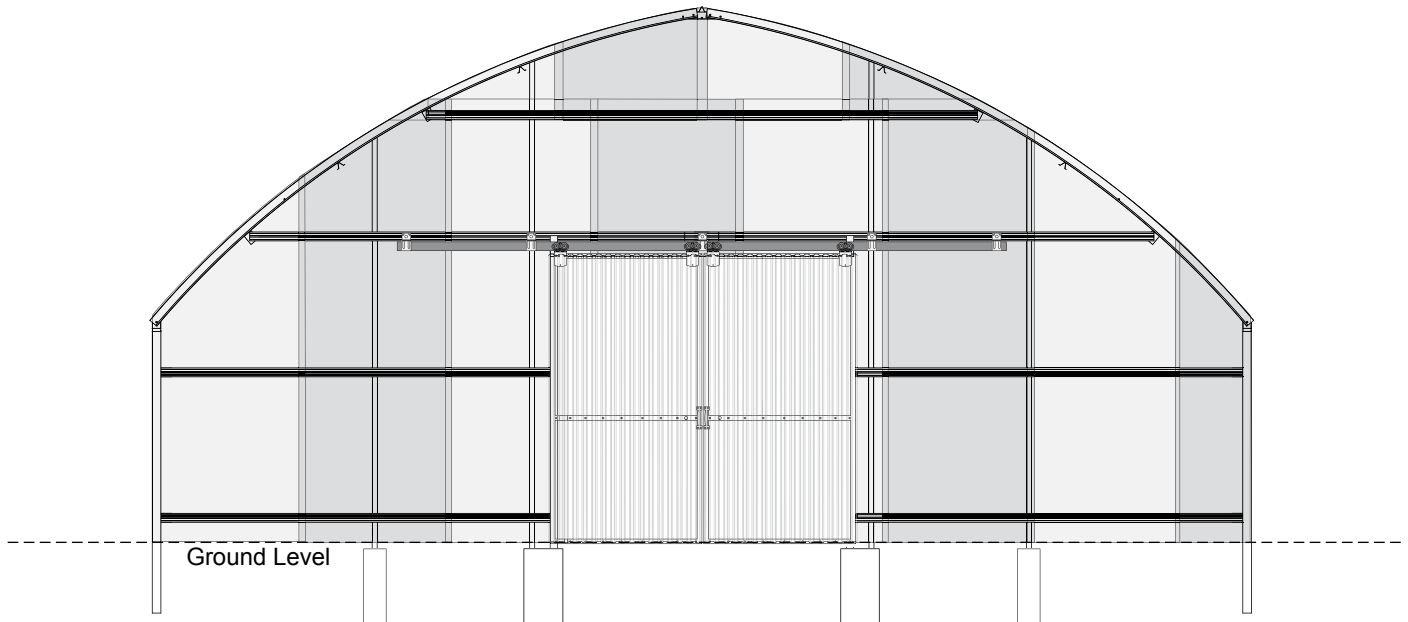

Diagram shows a corrugated sliding door centered and installed in an end wall frame. The door kit includes materials for the door only. All other components shown in the diagram above and other diagrams throughout this guide are not included and require additional purchase.

©2010 ClearSpan™
All Rights Reserved. Reproduction
is prohibited without permission.

STK# R035A00012A (Twin-Wall Polycarbonate) R035A00012B (Corrugated Polycarbonate)

Revision date: 05.28.10

Table of Contents

Important Information	3
Door Frame Assembly	5
Stay Roller Assembly	7
Sliding Door Track Assembly	8
Roller Assembly	11
Twin-Wall Double Sliding Door Assembly	13
Corrugated Double Sliding Door Assembly	15
Shelter Care and Maintenance	17
Quick Start Guide	18
Door Frame Layout	19
End Frame Dimensions	20
Notes	21

DOUBLE SLIDING DOOR KIT: READ THIS BEFORE YOU BEGIN

The double sliding door kit is designed to attach to the end wall framing kit (R035A00001). These instructions and the instructions for the R035A00001 end wall are written to be used together.

If you have not installed the R035A00001 end frame, consult these instructions as you assemble the framing for the door and end wall. Adjust dimensions as needed to accommodate the door installation and location.

NOTE: The R035A00001 end frame is designed to frame an end of one of our roll-form buildings (30' and 35'). Some end frame components may not be used if a door is installed in the end wall.

If you have already installed the R035A00001 end frame, use these instructions to determine the best location for the door and remove the end framing as needed to install this door kit. Reinstall end frame as described in this guide.

If you are installing this door kit in an end wall that is not the R035A00001 end wall, use these instructions for critical dimensions and details.

Consult the services of a qualified contractor if needed. *It is the responsibility of the owner/contractor to adapt these instructions to safely and competently install this door in an end wall or building that it was not designed for.*

Complete these steps to begin and to install the door:

1. Based on the door dimensions, determine where you can position the door in the end frame. Use the diagrams from both this manual and the end wall assembly guide.
2. Return to the end wall instructions and frame the end wall as needed based on the door location. Secure the door framing to the end wall framing.
3. Assemble the door and attach the assembled door to the door frame of the end wall.

NOTE: If you purchased a fabric end panel to cover the end wall, install the panel *before* you install the door; then remove the panel material as needed to allow for the installation of the door. If you purchased a polycarbonate package (8mm twin-wall or corrugated), install those panels *after* installing the door frame and *before* installing the door(s). **Consult the stay roller installation steps before installing the end wall polycarbonate panels.** Panels or parts of panels will remain from the end panel kit resulting from the installation of the door(s).

Important Information



YOU MUST READ THIS DOCUMENT BEFORE YOU BEGIN TO ASSEMBLE THE DOOR KIT.

Thank you for purchasing this ClearSpan™ door kit. When properly assembled and maintained, this product will provide years of reliable service. These instructions include helpful hints and important information needed to safely assemble and properly maintain the door. Please read these instructions **before** you begin.

SAFETY PRECAUTIONS

- Wear eye protection.
- Wear head protection.
- Use a portable GFCI (Ground Fault Circuit Interrupter) when working with power tools and cords.
- Do not climb on the framing during or after construction.
- Provide proper ingress and egress to prevent entrapment.

⚠ WARNING: The individuals assembling this door are responsible for designing and furnishing all temporary bracing, shoring and support needed during the assembly process.

For safety reasons, those who are not familiar with recognized construction methods and techniques must seek the help of a qualified contractor.

REQUIRED TOOLS

The following list identifies the main tools needed to assemble the door. *Additional tools and supports may be needed depending on the structure, location, and application.*

- Tape measure or measuring device
- Fine point marker to mark the location frame members.
- Variable speed drill and impact driver (cordless with extra batteries works best)
- Tool to cut the polycarbonate panels
- Hammers, gloves, and eye protection
- Ladders, work platforms, and other machinery for lifting designed to work safely at the height of the door and door frame.

ATTENTION: Consult the services of a qualified, professional contractor if you are not familiar with the construction of similar frame structures and components.

Important Information

ASSEMBLY PROCEDURE

Following the instructions as presented will help ensure the proper installation of the end frame and door. The steps outlining the assembly process are as follows:

1. Verify that all parts are included in the shipment. Notify Customer Service for questions or concerns.
2. Read these instructions and all additional documentation included with the shipment **before** you begin.
3. Gather the tools, bracing, ladders (and lifts), and assistants needed to install the doors and door frame.
4. Read the care and maintenance information at the end of these instructions.
5. Complete and return all warranty information as instructed.

UNPACK AND IDENTIFY PARTS

The following steps will ensure that you have all the necessary parts *before* you begin.

1. Unpack the contents of the shipment and place where you can easily inventory the parts. Refer to the Bill of Materials/Spec Sheets.
2. Verify that all parts listed on the Bill of Materials/Spec Sheets are present. If anything is missing or you have questions, consult the parts guide and all diagrams for clarification, or contact customer service.

NOTE: At this time, you do not need to open the plastic bags containing smaller parts such as fasteners and clamps (if equipped).

QUICK START DIAGRAMS

For a quick overview of the end wall, door, and components, consult the diagrams located at the back of these instructions.

PARTS IDENTIFICATION

The following graphics and photos will help identify the different hardware for each door. (Some parts are not shown.)



102921B & FA4484B
Tek Screws and neo-
bonded washers



108553
Wafer head screw

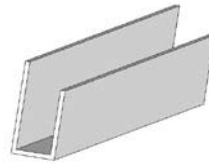

104213
Aluminum
U-Channel Profile
(Twin-Wall Only)

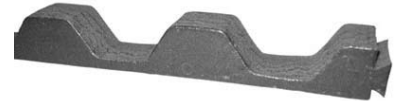

104709
Horizontal closure strip
(Corrugated Only)

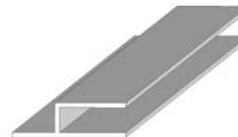

104548
End cap profile



100348
Bearing hanger roller



100356
Stay roller

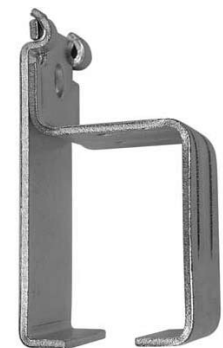

100380
Mounting bracket

Door Frame Assembly

ASSEMBLING THE DOOR FRAME COMPONENTS

Consult the diagrams at the back of these instructions *before* you begin. Assistance is required to assemble the door frame.

INSTALL THE DOOR JAMBS

The following steps describe one way to set the door jambs.

1. Using the dimensions from the *Door Frame Layout* located in the *Quick Start* section, locate and mark the positions of the door jambs.
2. Dig a 10"-12" diameter hole at the locations found in previous step to a depth that is *below the geographic frost line*. (Minimum depth: 24".)
3. Locate the 120" door jambs (105488120). Using a metal saw, cut and remove the 2-1/2" sections from one end of each door jamb as shown in photo A. *This creates a lip and allows the jamb to be attached to the girt (see photo B and C).*

ATTENTION: Diagrams A-D show the left door jamb only. *Adjust cuts when cutting the end for the right jamb.*

4. Using the diagrams as a guide, attach each jamb to the girts using 108553 wafer head screws as shown in photo C, D, and E. (Install end wall girts if needed.)

ATTENTION: Position the door jambs so the open sides of the C-channel face away from the door opening (as shown in the photo C) and the lip overlaps the girt. When attached to the girt, the lower end of each jamb extends into a ground anchor hole and is secured in place using concrete. *Consult a knowledgeable contractor if needed.* When installing the lower girts (if needed) of the end wall, verify that the inside-to-inside dimension for the door frame remains consistent.

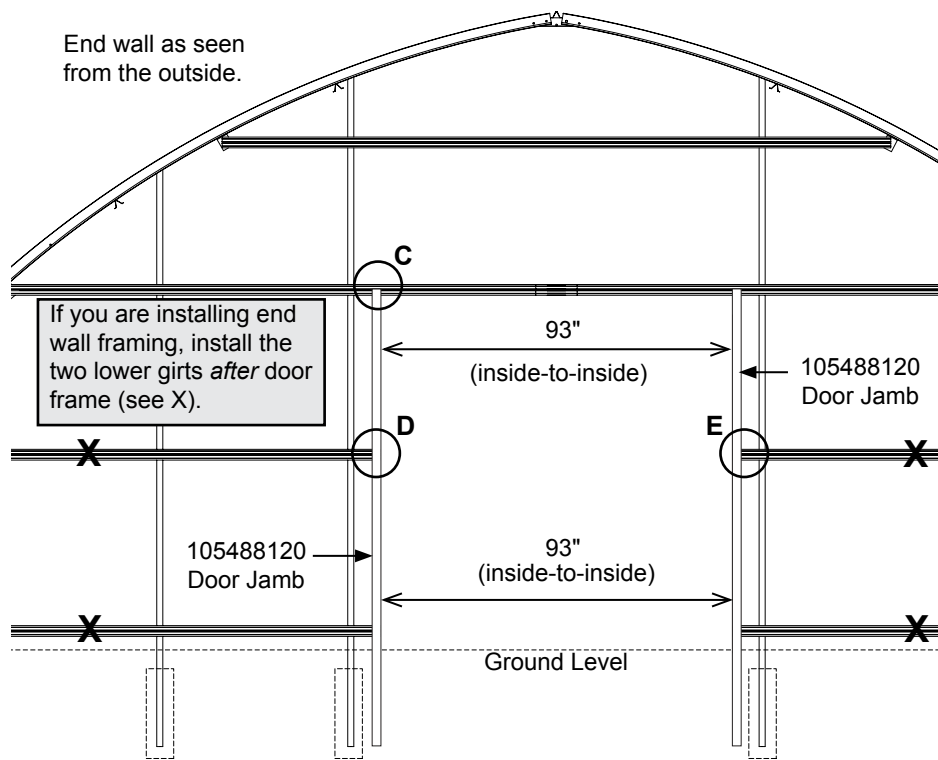
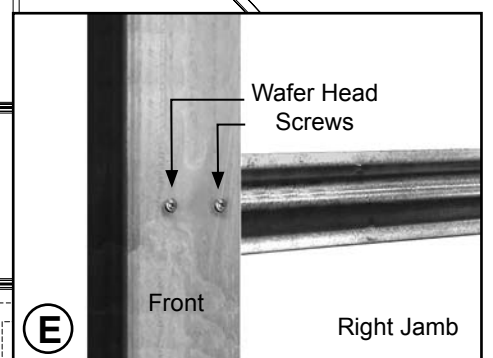
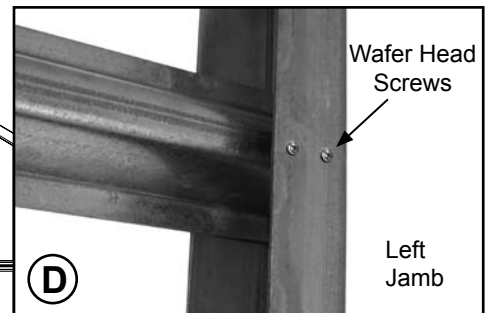
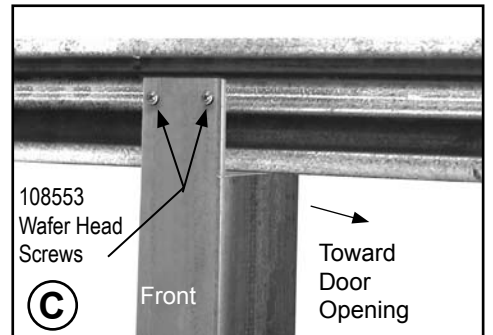
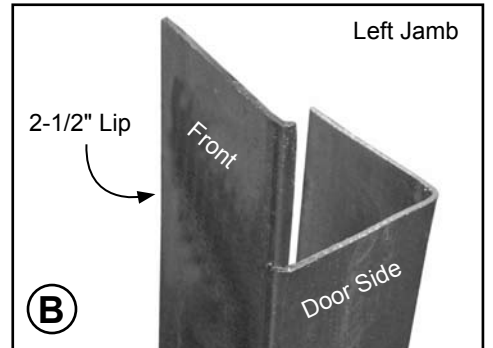
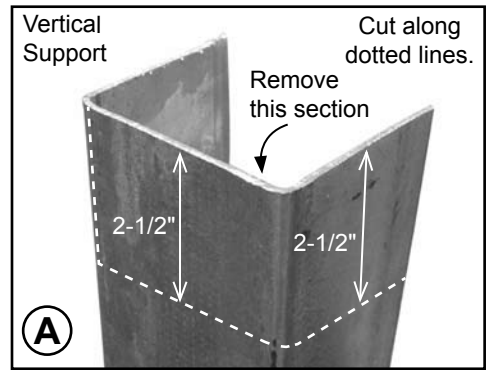

Door Frame Assembly

ASSEMBLING THE DOOR FRAME COMPONENTS (continued)

5. With the door jambs attached, measure and mark the height of the rough door opening. *Consult drawing below and the Door Frame Layout located in the Quick Start section located at the back of these instructions.* Measure from finished grade to underside of header.
 6. Locate the 105488120 header, measure the *outside-to-outside* distance of the door jambs and cut the header to required length.
 7. Using a metal saw, cut two 2" sections and bend the lip inward from both ends of the door header as shown to the right (see photos F and G). This creates two (2) lips and allows the header to be attached to the door jambs. **Open channel of the header points upward.**
 8. Drill a 3/8" hole near each end of the header to create a drain hole for the header. This helps prevent water from collecting inside the door header (see photo H).
 9. Position the header so that the two (2) lips on each side overlap the door jambs (see photo H) and align the bottom of the header with vertical support marks made in Step 5.
 10. With the header level, attach the front and back of the header to the door jambs using wafer head screws. Reinforce the header by securing the bent lip to the vertical support using Tek screws as shown in photo H. (Or, customer-supplied bolts can be used.)
 11. After the door frame is square and assembled, secure the door jambs in the ground using concrete.
- NOTE:** Concrete should remain at least 2"-4" below ground level so that it does not interfere with construction, installation of other end wall components (if equipped), or the operation of the door.
12. After assembling the door frame, continue with the stay roller assembly.

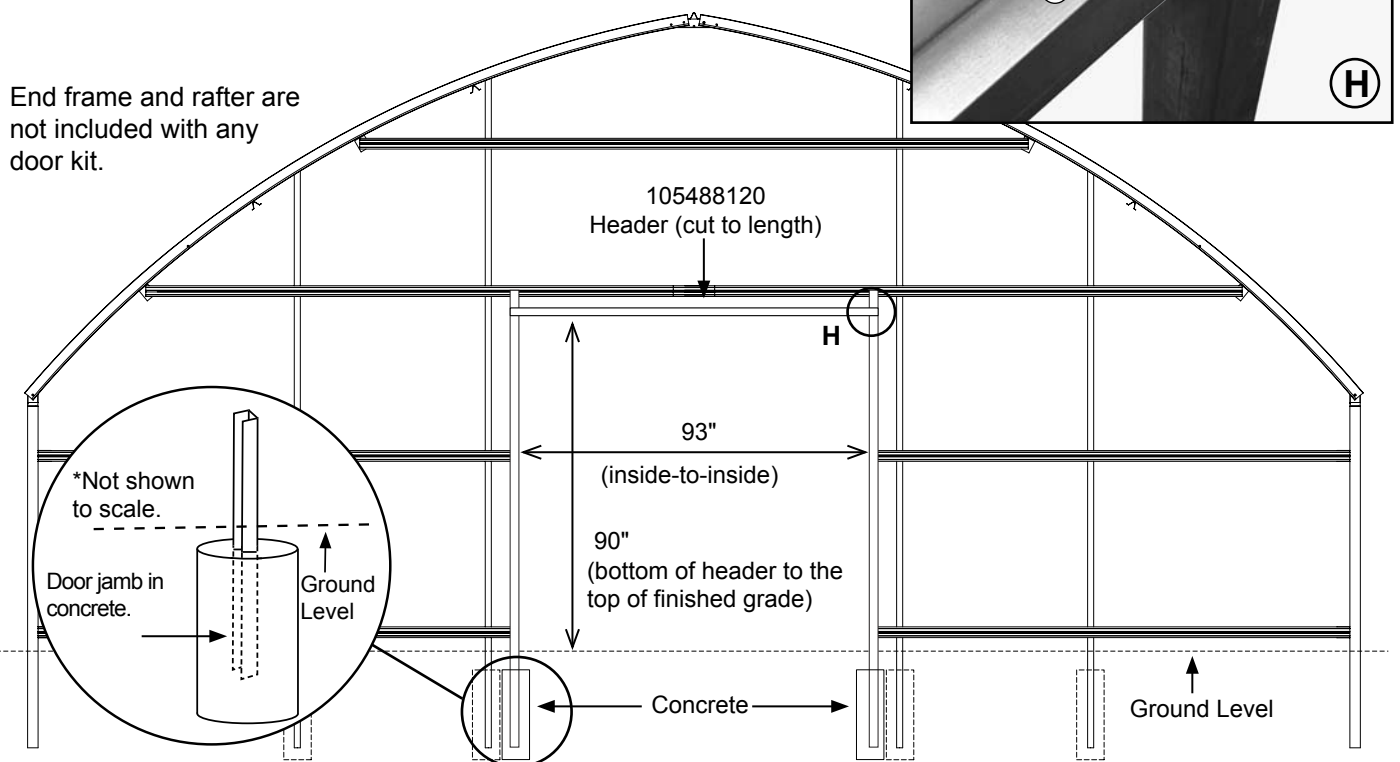
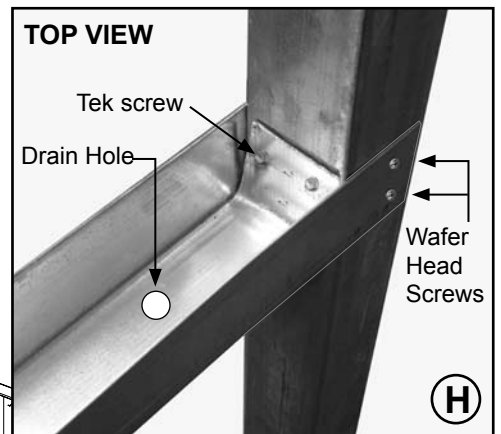
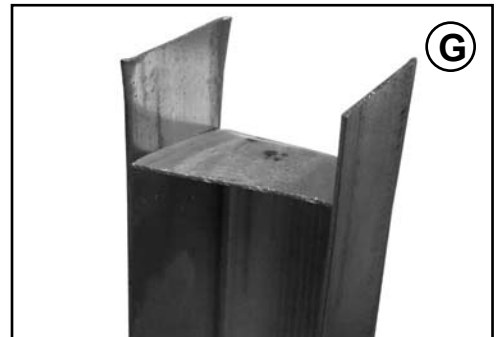
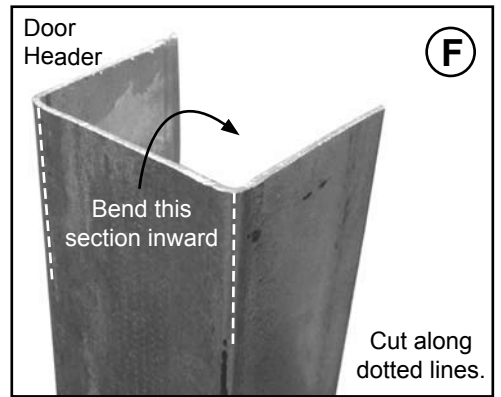

Stay Roller Assembly

ASSEMBLE AND ATTACH STAY ROLLERS

1. Locate the 100356 stay roller assembly and remove the roller, bushings, screws, bolt and nuts.

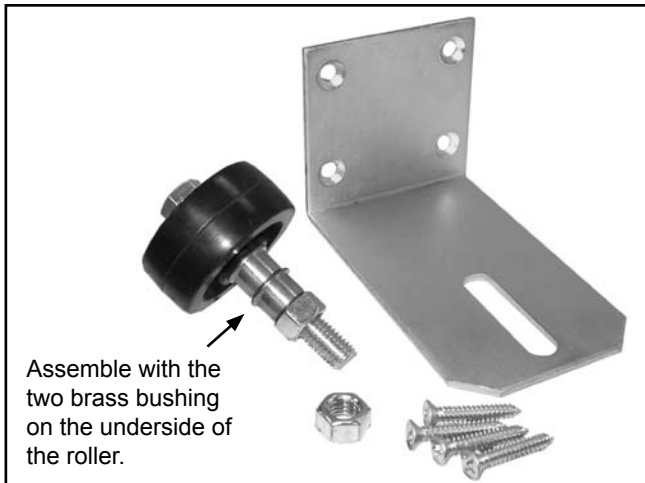

2. Secure the angle bracket in the lower-right corner of the assembled door frame as shown below. Allow clearance under bracket to attach roller assembly.

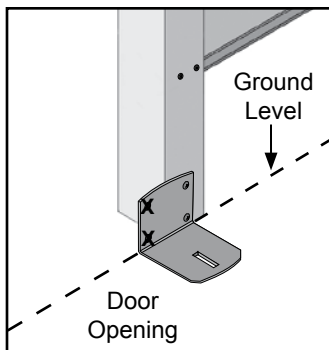

NOTE: Holes marked with an X will not be used.

If using the screws supplied with the roller assembly, drill two (2) pilot holes into the frame and attach roller assembly using two (2) screws.

3. Reattach the roller and related parts to the angled bracket attached to the end wall frame.

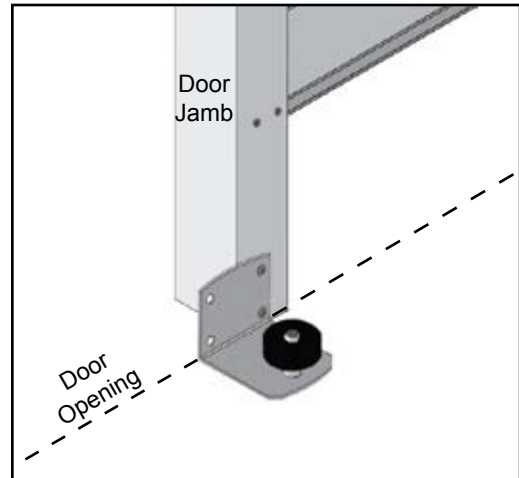

NOTE: Do not tighten the roller assembly at this time. It is adjusted and tightened when the door is installed.

4. Repeat the steps to attach the remaining stay roller assembly to the lower-left corner of the rough door opening. View is from outside the frame.

ATTENTION: After installing the stay rollers, return to and complete the assembly of the end wall frame (R035A00001 End Frame Kit if equipped) *before* installing the sliding door assembly. Additionally, the polycarbonate panels of any end wall PC package must be installed *before* you install the sliding door assemble. Complete the installation of all polycarbonate panels at this time for these kits: R030A00007, R030A00008, R035A00007 and R035A00008.

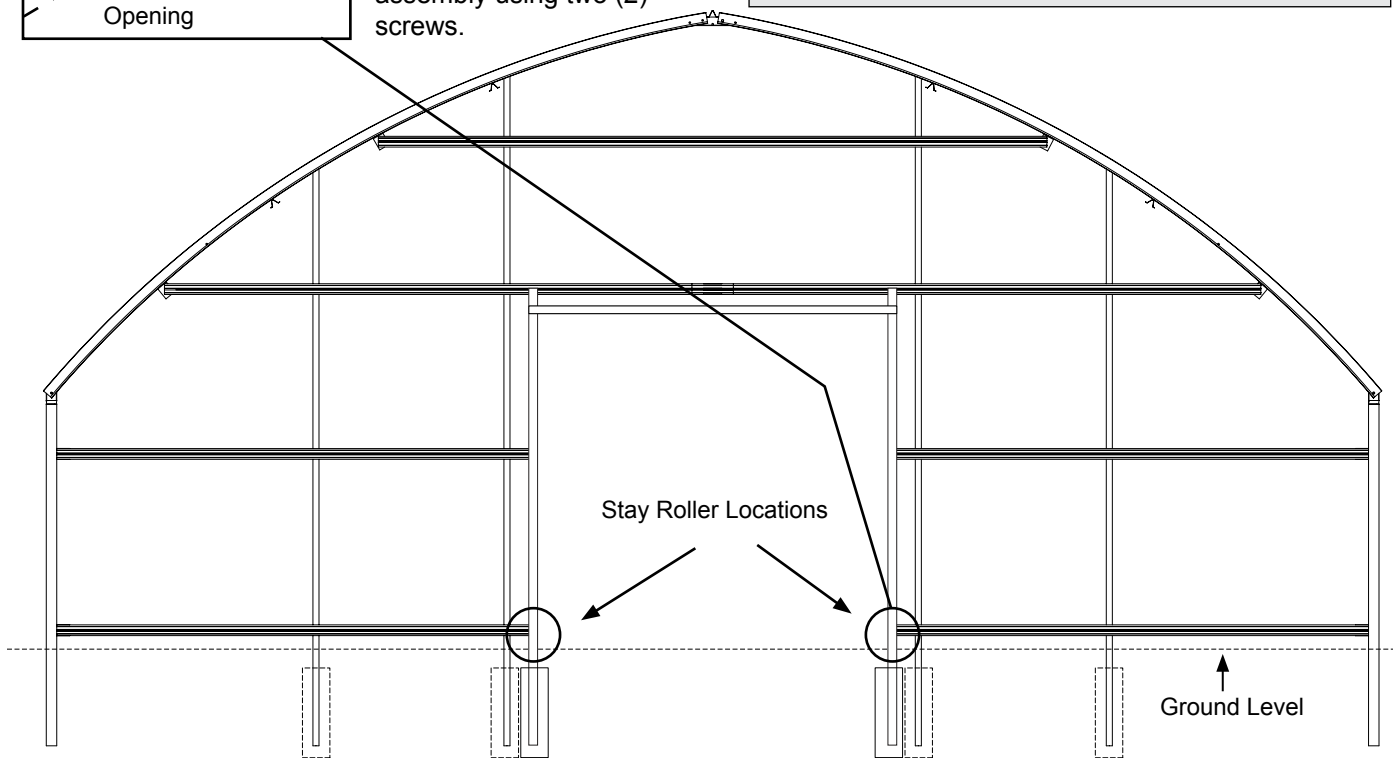

Sliding Door Track Assembly

ATTACH DOOR TRACK

Gather the parts:

- FAK26 3/8" threaded rod, FALB04B 3/8" nuts, FAME18B 3/8" SS flat washers, FAMA38B lock washers, and FAME52B 3/8" flat washers (for corrugated end walls only if equipped)
- FA4484B Tek screws and 102921B neo-bonded washers
- 100377 door track and 100380 hanger bracket for door track

Complete these steps to install the slider track. Complete only those steps that apply to the type of end wall polycarbonate (8mm twin-wall or corrugated) that covers the end frame. If you did not cover the end wall with a polycarbonate kit, choose the steps that best address the cover that is installed.

1. Along the girt in the locations shown below (see arrows), drill 3/8" holes through the steel tube framing, girt, and corrugated panel. Drill holes level and straight through to mount the brackets and track properly.
2. In locations *without a vertical end wall support behind the girt* (A, C, & E in the diagram below), cut a 6" section of girt channel and drill through both channels (2a). After hole is drilled, flip the 6" section, align the 3/8" holes, and secure 6" girt to end wall girt using four (4) Tek screws (2b).
3. For 8mm twin-wall polycarbonate end wall panels: Move outside the end wall, and drill a one-inch (1") hole in the polycarbonate panel at each 3/8" mounting hole location (2c).

For corrugated end wall panels, continue with the next step.

Diagram to the right shows a front view of the 8mm twin-wall polycarbonate panel with the end wall girt behind it. Hole in girt is 3/8"; hole in panel is 1". Applies to twin wall panels only.

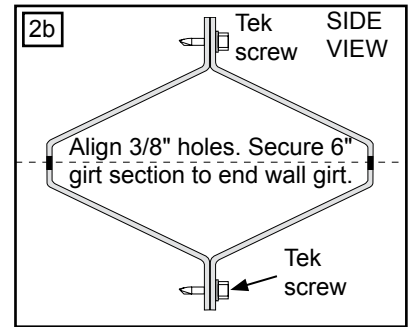
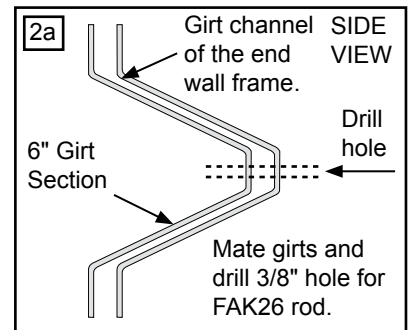

Views as shown with the inside of the shelter on the left and the outside on the right. *End wall panels are not shown in diagrams.*

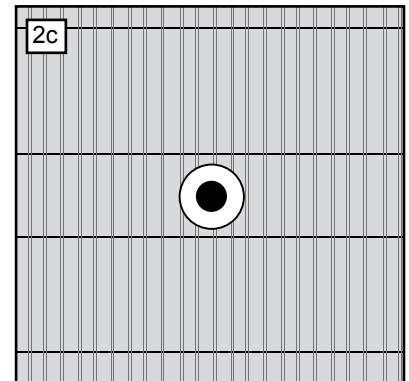

NOTE: Space holes for brackets as needed to properly support the sliding doors. Spacing may differ from what is shown depending on position of door.

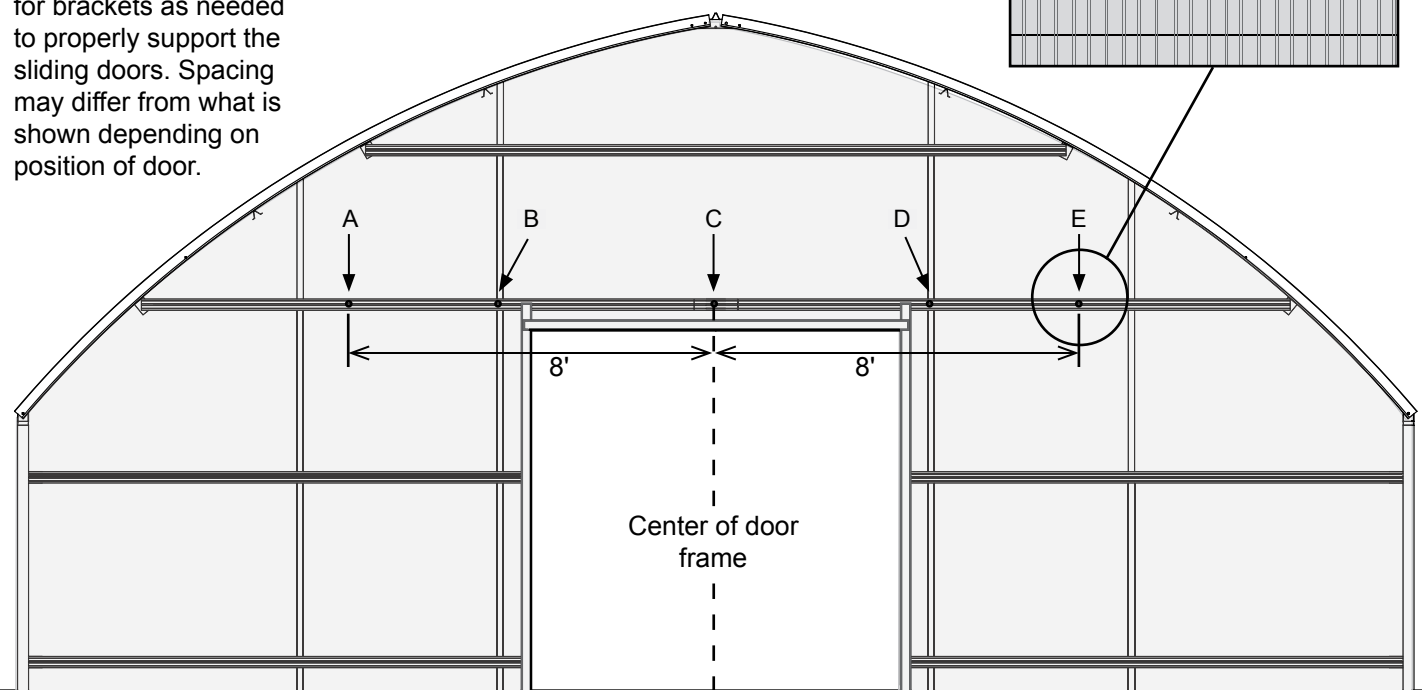

Sliding Door Track Assembly

ATTACH DOOR TRACK (continued)

4. Insert a 3/8" mounting rod (FAK26) through one 3/8" mounting hole from inside the building. On the inside of the building, add a FAME18B flat washer, FAMA38B lock washer, and a FALB04B nut to the end of the 3/8" rod. (See diagram 3a and 3b.)
5. Move outside the end wall and add a FAME18B flat washer and 3/8" nut. Tighten to secure the rod to the girt. Repeat to install the remaining FAK26 3/8" rods.

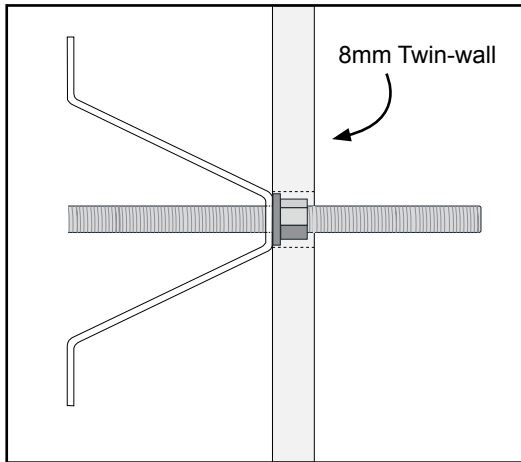

NOTE: Diagram above shows twin-wall panel covering the end wall. If there is an open space between the hole in the corrugated panel and the girt as shown in the example below (4a), install as many FAME52B washers as needed to fill the gap (4b). *Does not apply to twin-wall panels.*

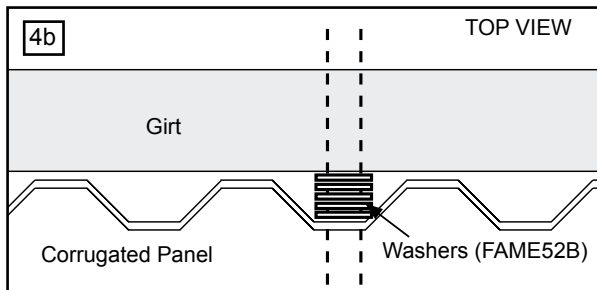
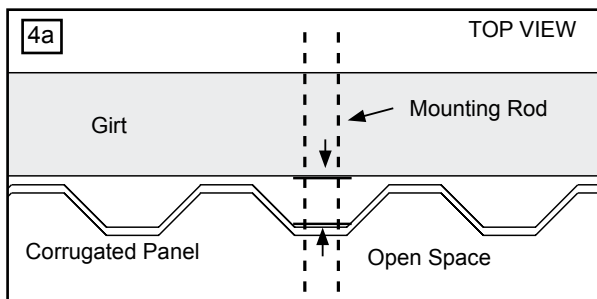

Install washers from inside the shelter by holding washers up from behind the girt and pushing the mounting rod through.

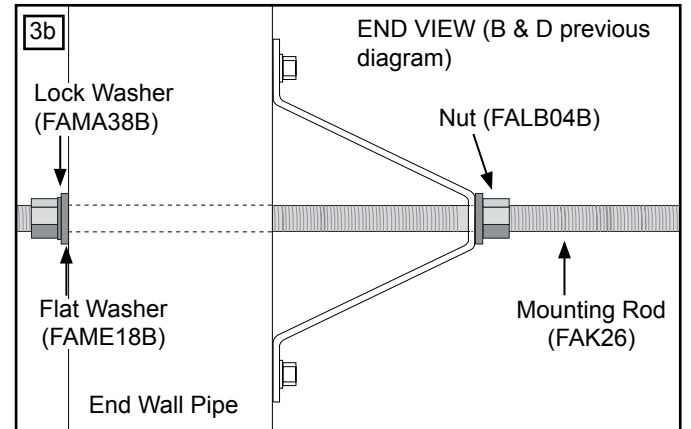
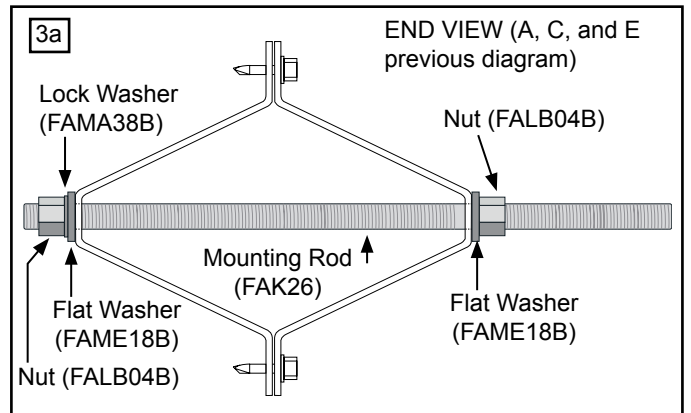

6. For the corrugated end wall panels, install another 3/8" nut and FAME18B flat washer onto each mounting rod as shown below. These allow the door track to be adjusted when it is attached. See note below.

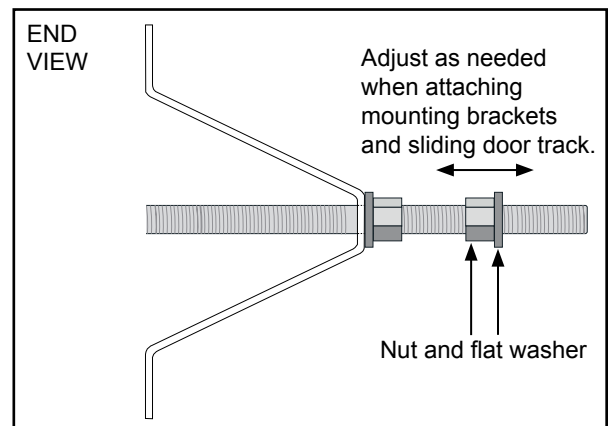

NOTE: This step is not required for twin-wall polycarbonate panels or for *corrugated panels* when the 3/8" mounting rod has been secured against the washers as shown in 4b.

Sliding Door Track Assembly

ATTACH DOOR TRACK (continued)

7. Slide two track mounting brackets onto one sliding door track as shown below. See arrows in diagram.

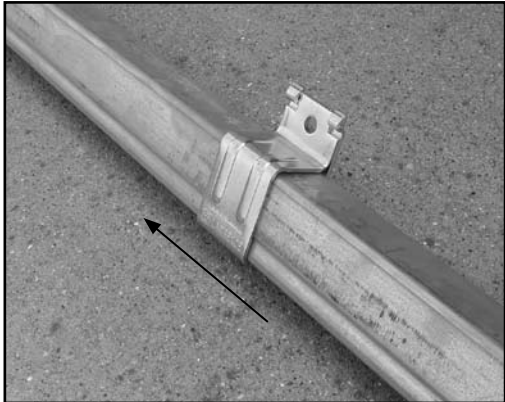

8. Align the brackets with the two outer mounting rods, adjust the previously installed nuts and washers as needed until the track is in the correct position, and install a flat washer, lock washer, and a nut.

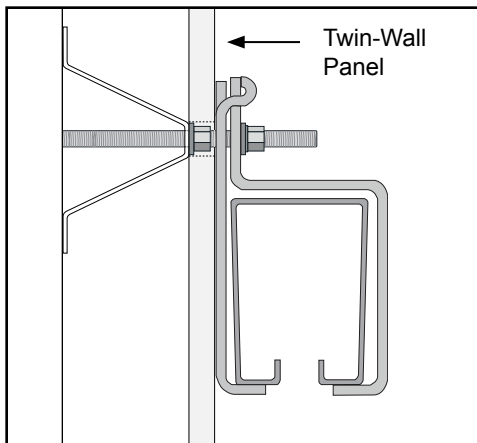

9. Verify that the track is level and flush to the inside edge of the end wall and tighten the 3/8" nuts. The mounting rods can be trimmed if desired. Repeat steps for remaining door track.

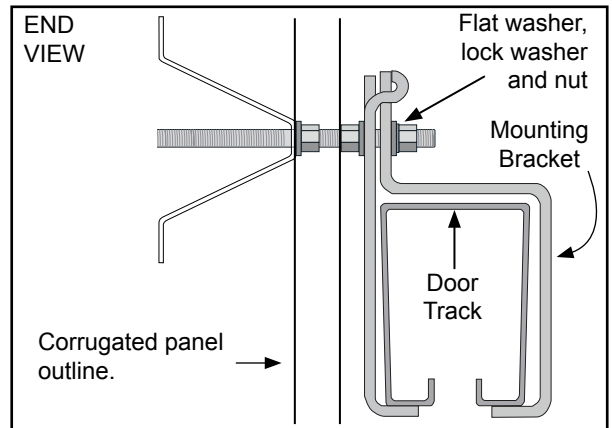

NOTE: The center track mounting bracket covers the joint where the separate track sections meet at the center of the end wall.

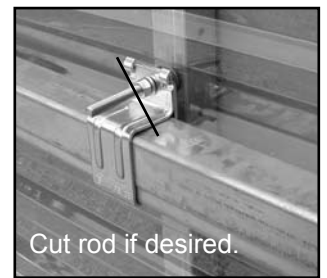

10. Continue by attaching the roller assemblies to the door frames.

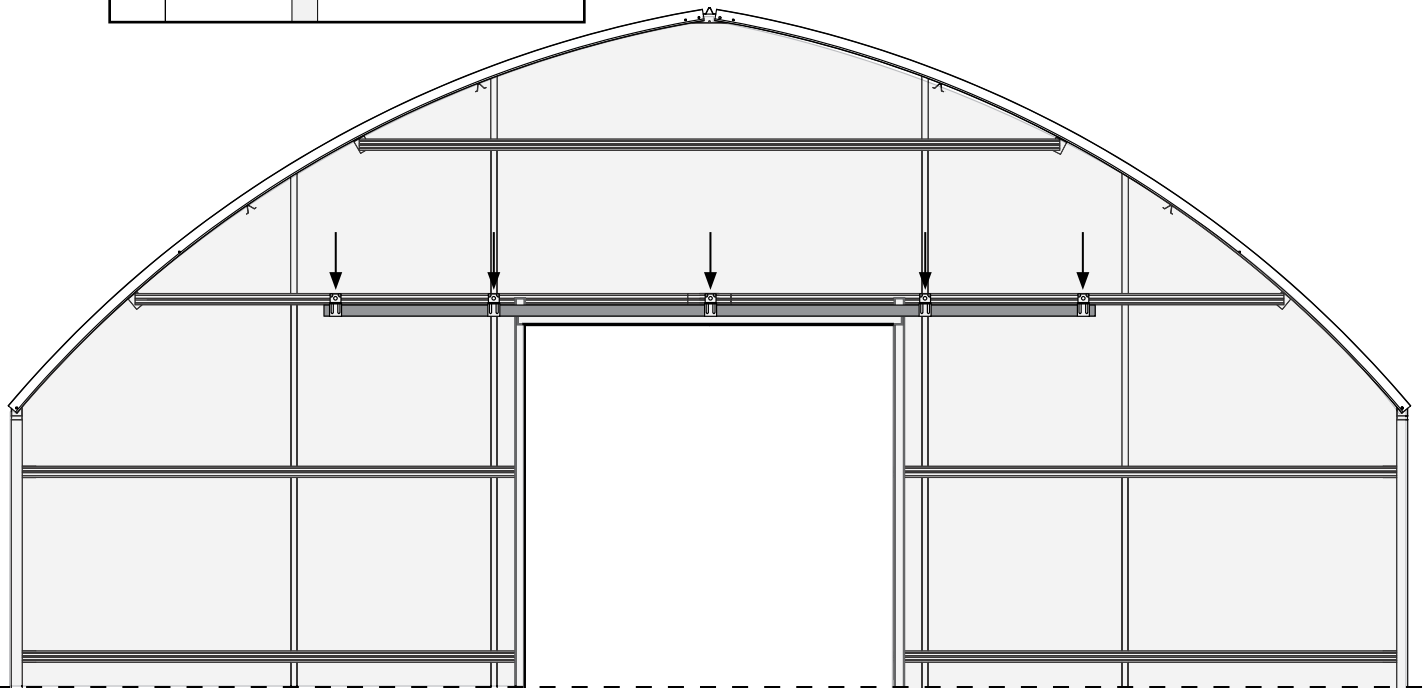

Roller Assembly

ATTACH ROLLER ASSEMBLIES TO DOOR FRAMES

Roller assemblies are attached to the top of each door frame. Use the following steps to assemble the rollers and brackets and to attach them to the tops of the doors.

NOTE: Photo shows an assembled roller attached to the top of a door frame. The view is from the inside/backside of the door. The small angled bracket is installed on the back of the door or to the inside of the building.

Small Angled Bracket

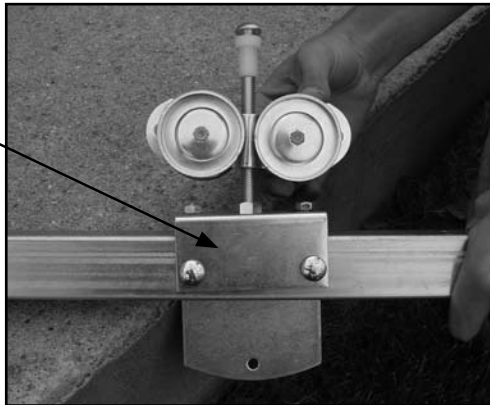

1. Position the small angled bracket a few inches in from the edge of the door frame. Align the square holes in the bracket with the center of the door frame tube.

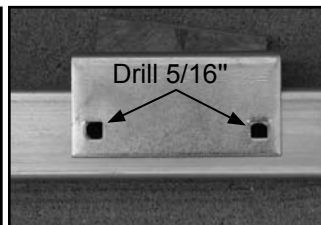
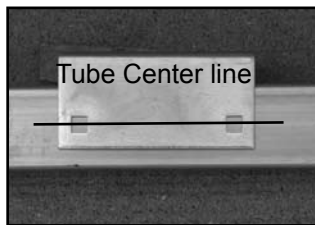

NOTE: The bracket cannot sit tight against the top of the frame. Space must exist between the frame and the bracket to allow for the adjusting nut and the bracket bolts.

2. Using the square holes in the bracket as a template, drill 5/16" holes through door frame.
3. Assemble the angle brackets and flat plate as shown.

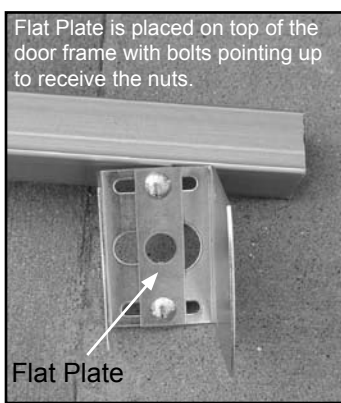
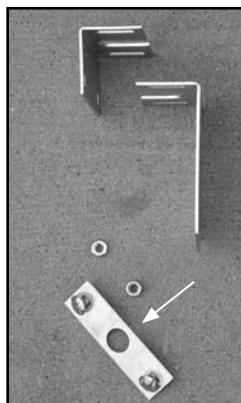

4. Temporarily insert carriage bolts through the brackets and tube to hold the assembly in place.
5. Align the center of the hole in the flat plate with the center line of the tube and mark the location of the adjusting bolt hole on the top of the door frame tube.

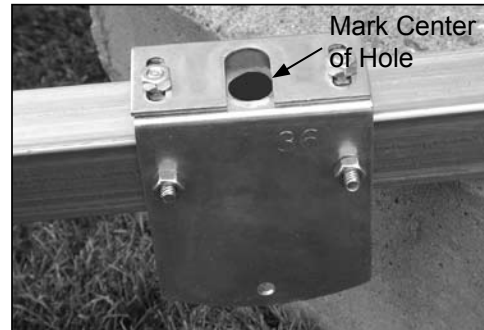

6. Drill a 1/2" hole through the door frame tube. The hole allows the adjusting bolt of the roller assembly to extend through the tube if needed.

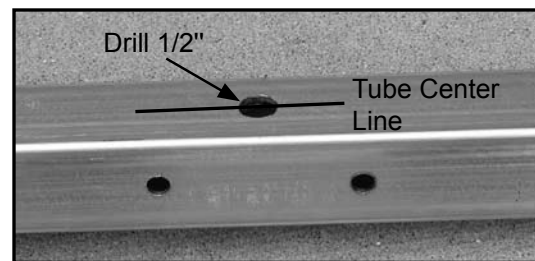

7. Place the adjusting nut on the door frame and install the assembled brackets and flat plate.

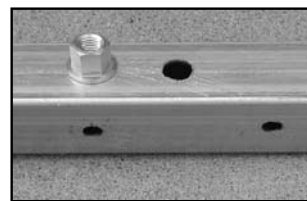

NOTE: Assembly is shown looking from the front or outside. Carriage bolts for the brackets must be inserted from the back to prevent damage to the building siding when the door is operated.

8. Adjust the flat plate to align the adjusting nut with the 1/2" hole drilled in the door frame tube. The adjusting nut must turn freely between the brackets and the top of the door frame. Tighten all bolts. See the above photos.

Roller Assembly

ATTACH ROLLER ASSEMBLIES (continued)

9. Install the adjusting bolt and roller assembly. Position the notch of the roller assembly up and away from the door.

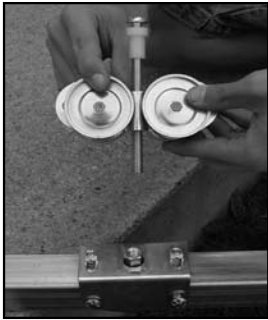

Space below is reserved for customer notes.

10. Repeat the steps to assemble and attach the remaining roller assemblies to the door frames. Photo below shows the attached roller assembly as seen from the outside or front.

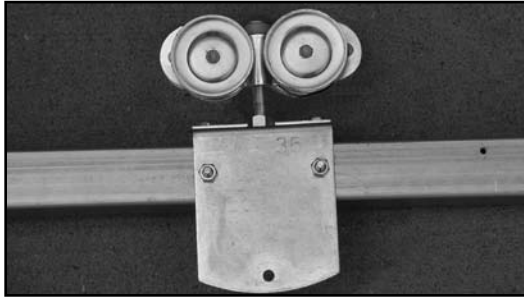

11. After attaching the roller assemblies, turn the door frame on its side and drill a hole in the bottom of the frame tube. (This hole will allow water drain from inside the door frame if it finds its way through the adjusting hole at the top of the frame.)
12. With all roller assemblies attached, continue by preparing and attaching the sliding doors.

If you have purchased the twin-wall double sliding door, read and complete the *Twin-Wall Double Sliding Door Assembly* (R035A00012A) instructions that follow.

If you have purchased the corrugated double sliding door, skip to and continue with the *Corrugated Double Sliding Door Assembly* (R035A00012B) instructions.

Twin-Wall Double Sliding Door Assembly

TWIN-WALL DOOR ASSEMBLY

If your door includes corrugated polycarbonate panels, skip this section and continue with the assembly steps for those doors. The materials and parts needed to assemble the R035A00012A doors include:

- Door frame (#102923)
- 8mm panel (#102908)
- Door handles (#100362)
- Tek screws (#FA4484B)
- Neo-bonded washers (#102921B)
- Aluminum profile (#104213)

Assemble and Attach the Door

NOTE: Install the polycarbonate panel with the UV-protected side toward the outside/sun.



1. Locate door frame (#102923) and place it on a flat surface.
 2. Take the polycarbonate panel and trim it so that the length is one-quarter inch (1/4") shorter than the length of the door frame.
 3. Trim the width of the polycarbonate panel so that it is one-quarter inch (1/4") narrower than the width of the door frame.
- NOTE:** Trimming the panels as instructed will keep the panel flush with the edge of the door frame *once the aluminum profile (104213) is installed.*
4. Center the panel on the door frame so that approximately one-eighth of an inch (1/8") of the door frame extends beyond the edge of the panel.

5. Using Tek screws (FA4484B) and galvanized neo-bonded washers, attach the panel to the horizontal cross tube of the door frame. *Evenly space Tek screws and washers every 12".*

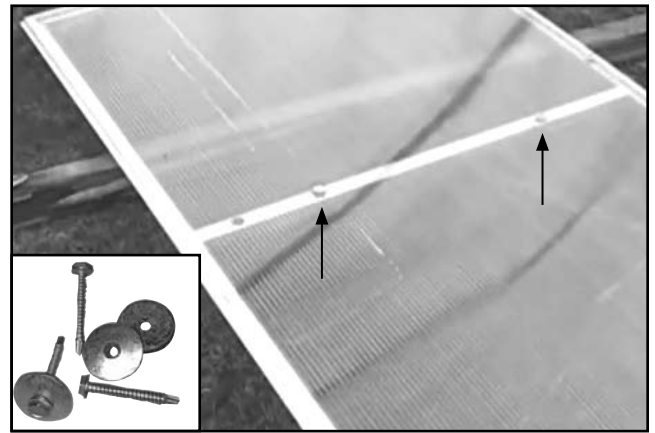

NOTE: Attach the panel in the locations shown in the photo to hold the panel in place while attaching the aluminum profile to the perimeter of the panel.

6. Install aluminum U-channel profile to all edges of the polycarbonate panel. The 104213 sections at the top and bottom of the panel run to the panel edges to seal the cells in the panel.

Photo shows the polycarbonate panel attached to the outside of the door frame and finished with the aluminum (104213) U-channel profile.

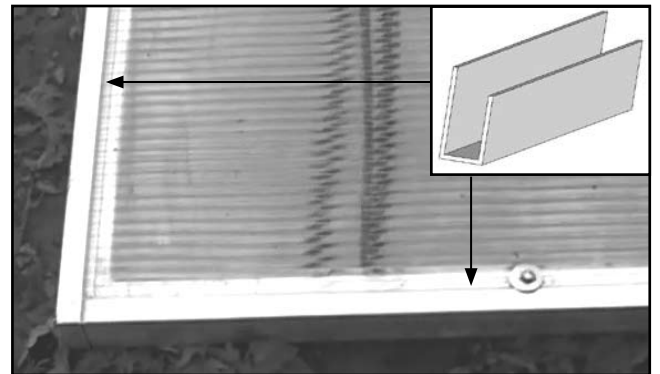

7. To keep the panel and profile in place, install Tek screws and neo-bonded galvanized washers so the screw drills through the longer edge of the U-channel (underside of the polycarbonate panel) and the washer overlaps the shorter edge of the U-channel (top) as shown above. *Evenly space Tek screws every 12".*
8. Repeat steps for remaining door.

Twin-Wall Double Sliding Door Assembly

TWIN-WALL DOOR ASSEMBLY (continued)

9. With both doors assembled, lift each door up and into place with the panel facing out and insert the rollers into the track. Assistants may be required.
10. Slide both doors to the center of the door opening to the closed position and adjust the nuts on the roller assemblies as needed to level the doors so they meet evenly at the center.

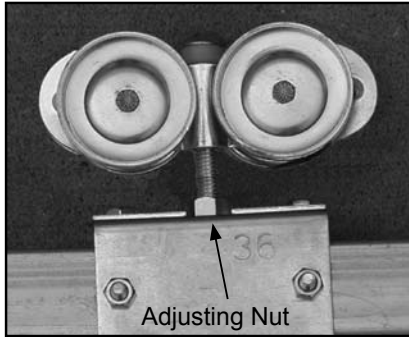

11. Adjust the stay rollers as needed.

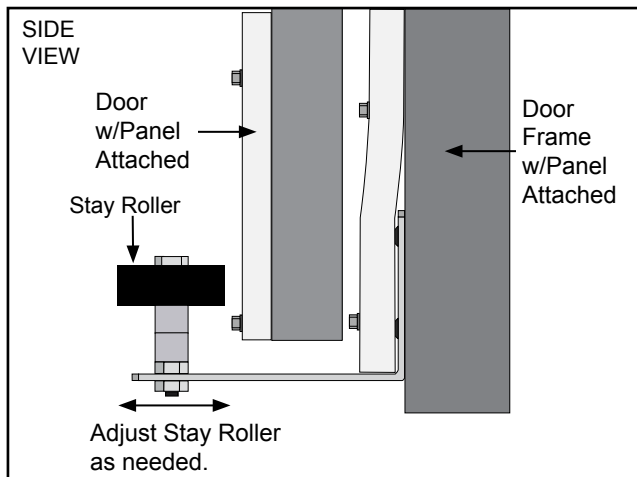
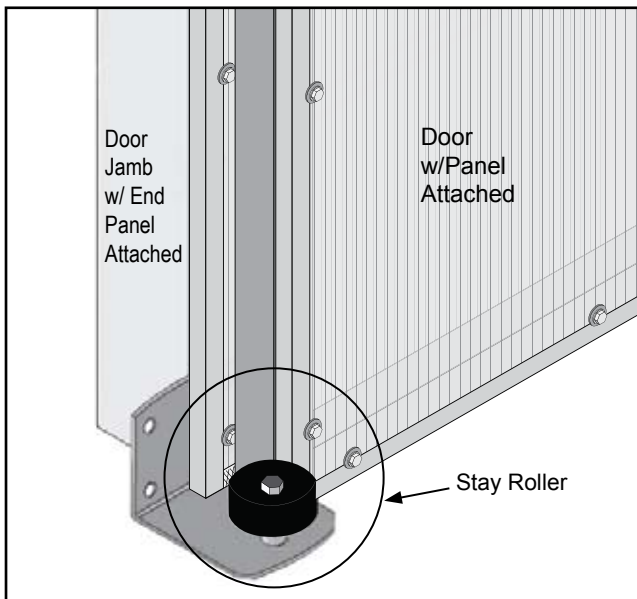

12. After adjustments are made, slide one door to its open position and install two Tek screws through the front of the door track to prevent the door from sliding out of the track. Repeat for remaining door.

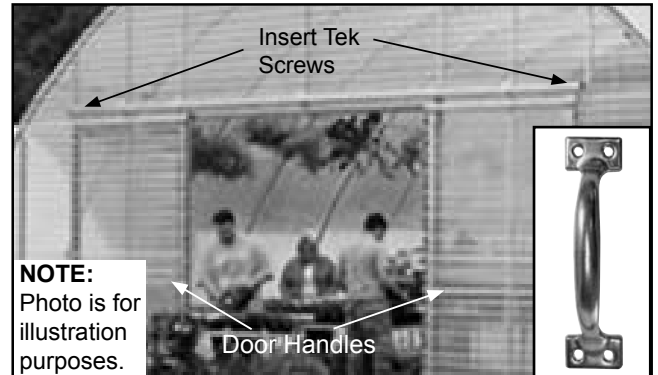

13. Install the door handles in the desired locations, using Tek screws through the panel and *into the door frame*. Handles can be installed vertically or horizontally.
14. Install the 104548 profile along the end wall door frame as shown in the following photos.

ATTENTION: The installation of the 104548 profile is an optional step for those who want to cap the end of the end panels at the door opening. Use Tek screws to secure the profile to the end wall framing.

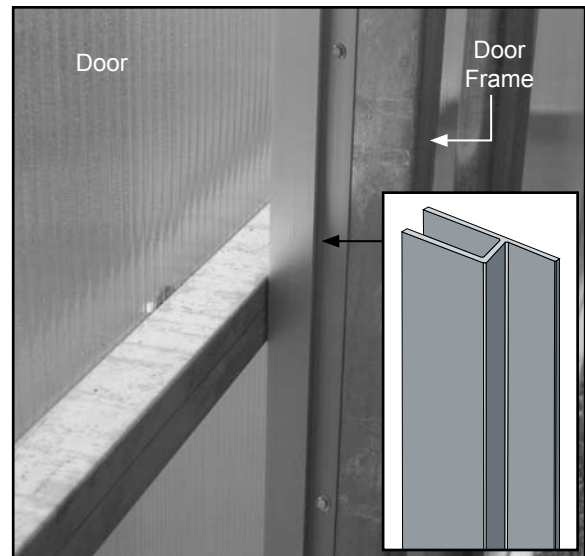

View is from the inside of the frame looking at the point where the door meets the door frame of the end wall.

15. Check the door operation and verify that doors slide smoothly in the door track and that the panels do not catch on any frame member. Adjust as needed.
16. Continue by reading the care and maintenance information.

Corrugated Double Sliding Door Assembly

CORRUGATED DOOR ASSEMBLY

The materials and parts needed to assemble the R035A00012B doors include:

- Door frames (#102923) and corrugated panels
- Tek screws (#FA4484B)
- Neo-bonded washers (#102921B)
- Horizontal closure strips (#104709)

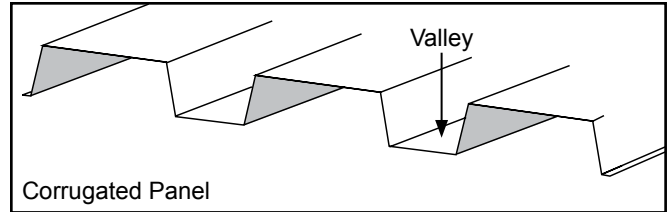

NOTE: Verify that the horizontal closure strip under the panel is in place *before* attaching the panel to the door frame.

Assemble and Attach the Door

1. Locate door frame with roller assemblies attached and place it on a flat surface.
2. Select one (1) corrugated panel and trim it so that the length is one-quarter inch (1/4") shorter than the length of the door frame.
3. Install sections of the horizontal closure strips under the panel (see Detail A) and *before* attaching the panel to the horizontal cross tube. *Trim one (1) closure strip as needed for all three locations.*
4. Install Tek screws and washers through the panel, closure strip, and into the horizontal cross tube every 6" or so. *Always install Tek screws and washers in the valleys of the panel. Do not overtighten screws.*
5. Attach the panel in the locations shown below to hold the panel in place.
6. Secure the sides of the polycarbonate panel to the door frame using Tek screws only every 16" (see Detail B).
7. Repeat for remaining door.

Dashed lines identify the positions of the foam closure strip (104709).

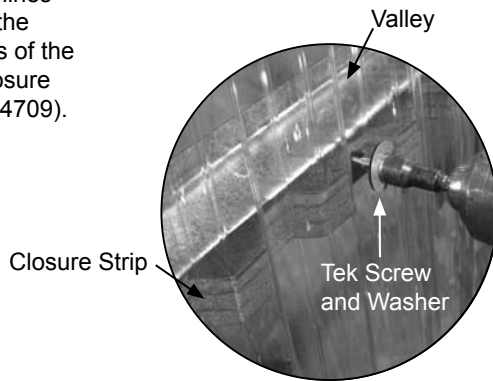

DETAIL A

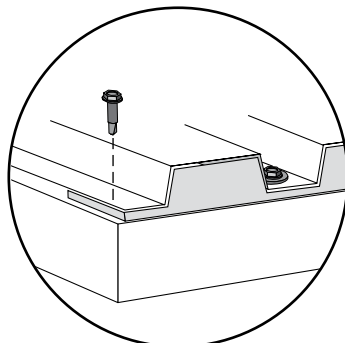

DETAIL B

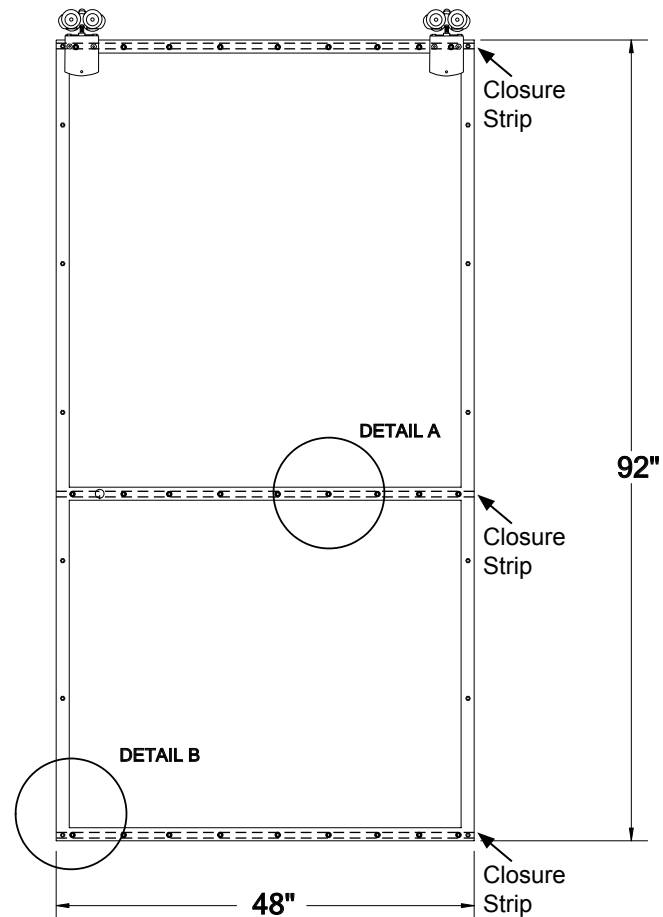

Corrugated Double Sliding Door Assembly

CORRUGATED DOOR ASSEMBLY (continued)

- With assistants, lift each door up and into place with the panel facing out and insert the rollers into the track.
- Slide both doors to the center of the door opening to the closed position and adjust the nuts on the roller assemblies as needed to level the doors so they meet evenly at the center.

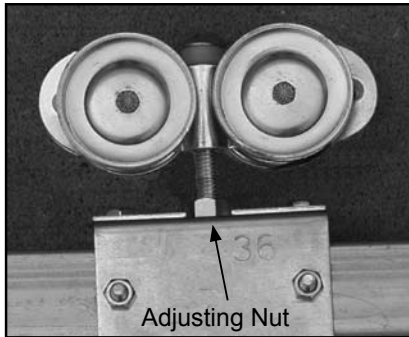

- Adjust the stay rollers as needed and tighten.

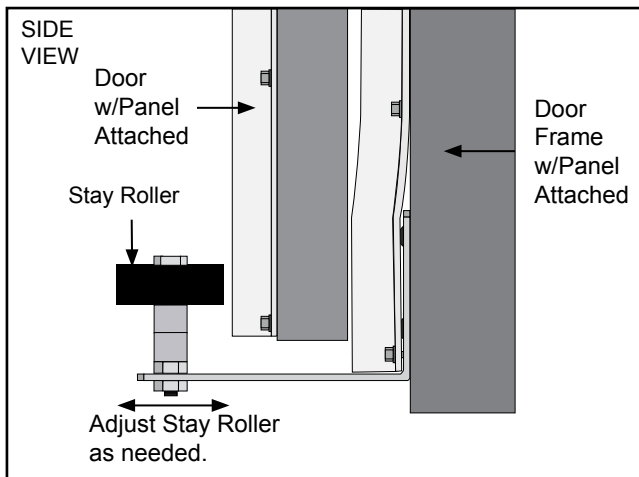
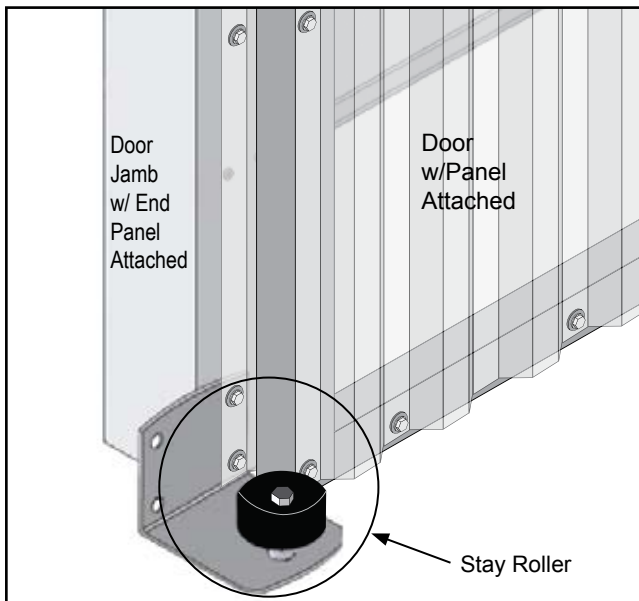

- After adjustments are made, slide one door to its open position and install two Tek screws through the front of the door track to prevent the door from sliding out of the track. Repeat for remaining door.

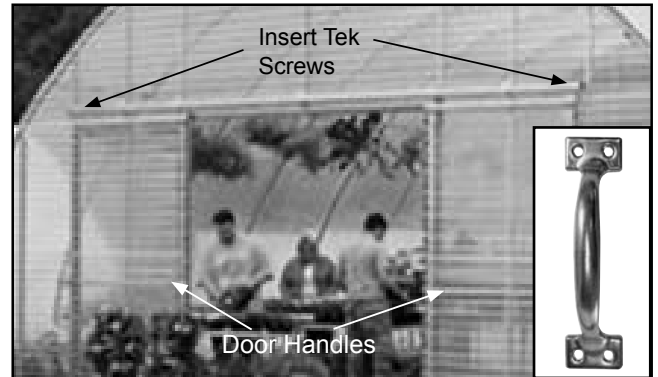

- Install the door handles in the desired locations, using Tek screws through the panel and into the door frame.
- Install the 104548 profile along the end wall door frame as shown in the following photos.

ATTENTION: The installation of the 104548 profile is an optional step for those who want to cap the end of the corrugated end panels at the door opening. Use Tek screws to secure the profile to the end wall framing.

Photo below shows end wall without installed profile. Dashed line shows where to install profile to cover the valleys of corrugated end panels. *View is from the inside of the frame looking at the point where the door meets the door frame of the end wall.*

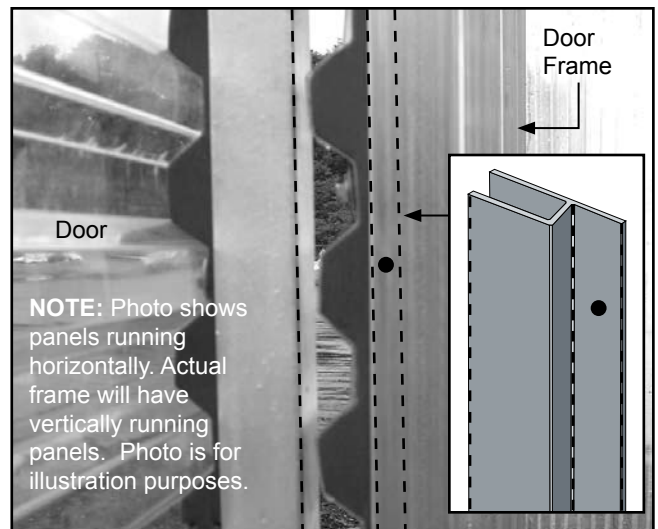

- Check the door operation and verify that doors slide smoothly in the door track and that the panels do not catch on any frame member. Adjust as needed.
- Continue by reading the care and maintenance information.

Shelter Care and Maintenance

SHELTER CARE AND MAINTENANCE

Proper care and maintenance of the door are important. Check the following items periodically to properly maintain the door and door frame:

- Regularly check the polycarbonate panels to see that they remain secure and in good condition. Replace damaged panel if needed.
- Check connections and all fasteners to verify that they remain tight.
- Check the contents of the shelter to verify that nothing is touching the polycarbonate panels that could cause damage or interfere with the door operation.
- ***For safety, doors must remain fully opened or fully closed. Do not leave doors ajar.***
- Check all slider mounting bolts regularly and tighten as needed.
- Replace damaged or broken parts immediately.
- Lubricate roller assemblies as needed to keep them operating smoothly.
- For replacement or missing parts, contact you sales representative for assistance.



Space below is reserved for customer notes.

Quick Start Guide

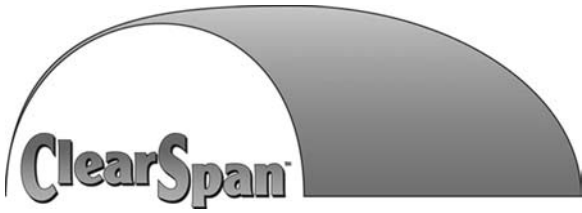

QUICK START GUIDE

Double Sliding Door Kit (R035A00012A and R035A00012B)

Twin-Wall Door Sample
R035A00012A

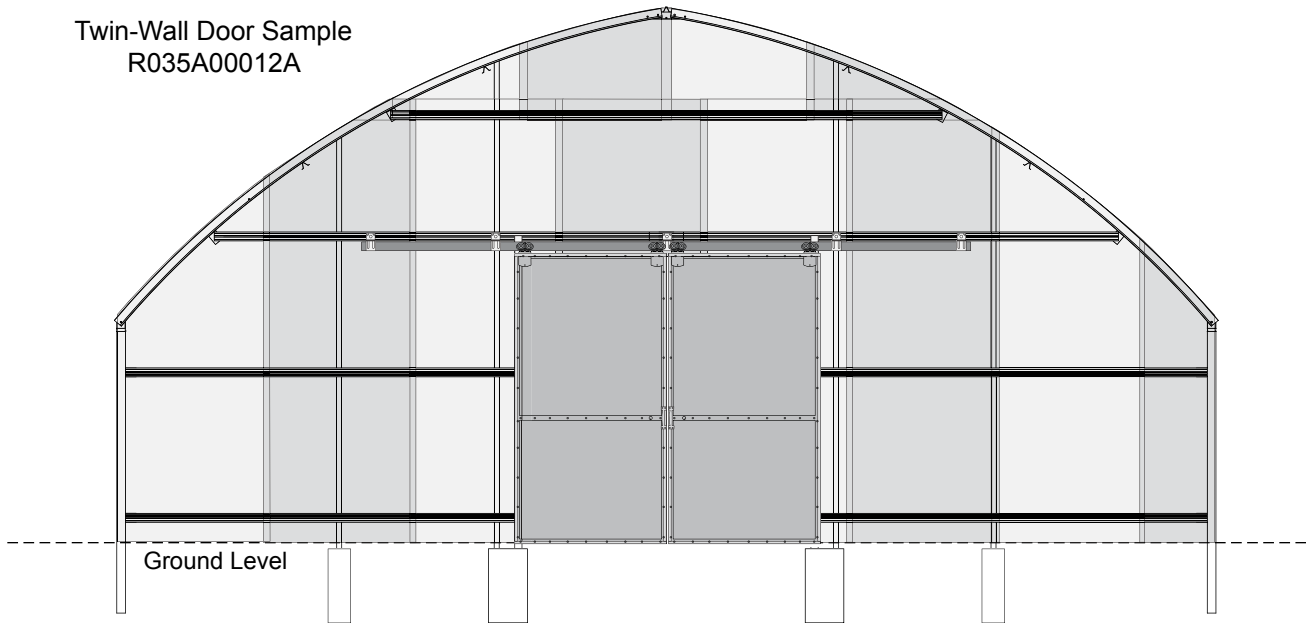

End frame and end rafter are not included with any door kit.

Corrugated Door Sample
R035A00012B

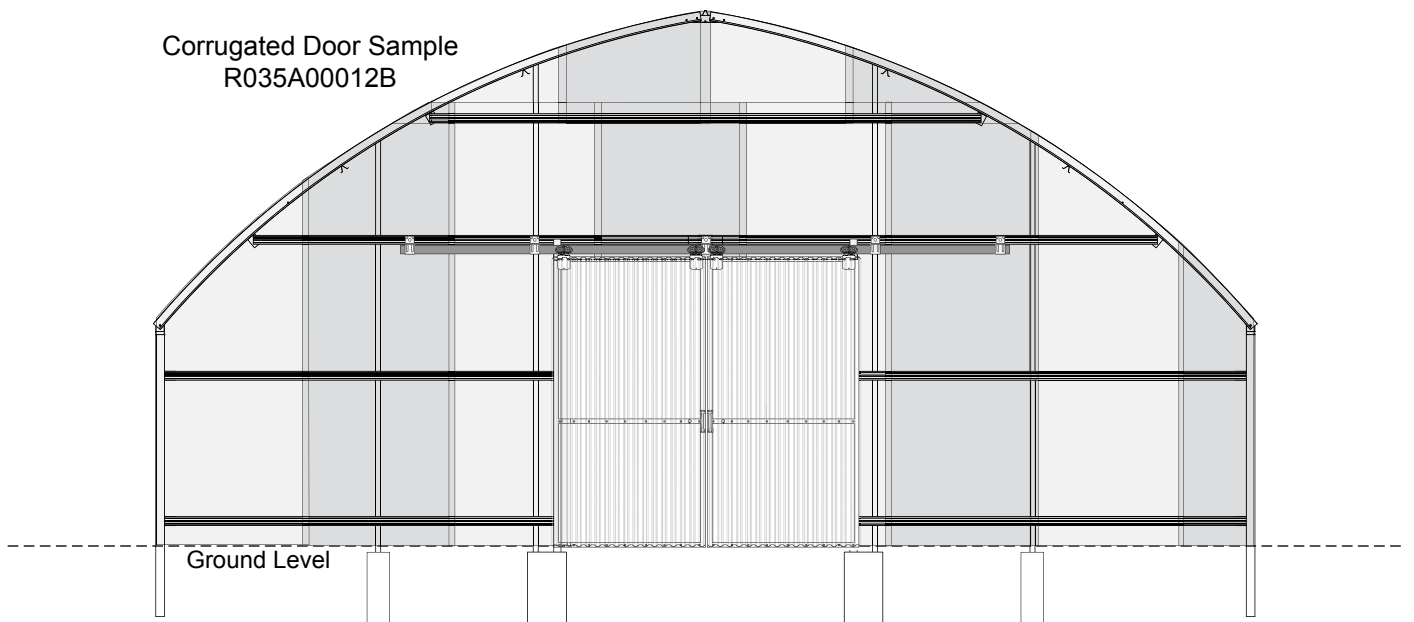

Door Frame Layout

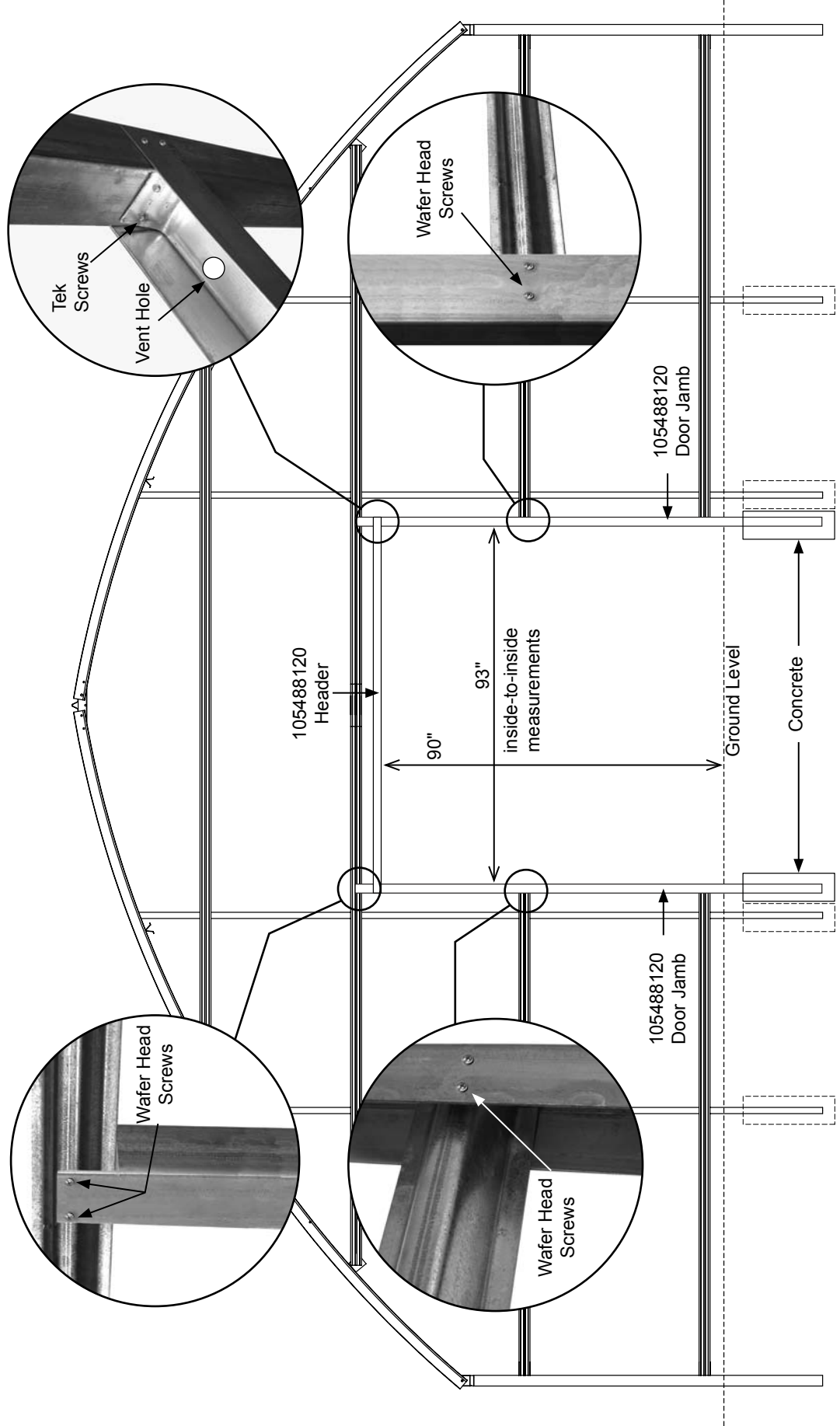

End Frame Dimensions

ATTENTION: Using the end wall instructions (R035A00001) and the dimensions shown below, set the end wall girt at the required height. The slider rails for the doors are secured to this end wall frame member.

Install all other horizontal end wall girts using the dimensions shown on the R035A00001 End Wall Kit.

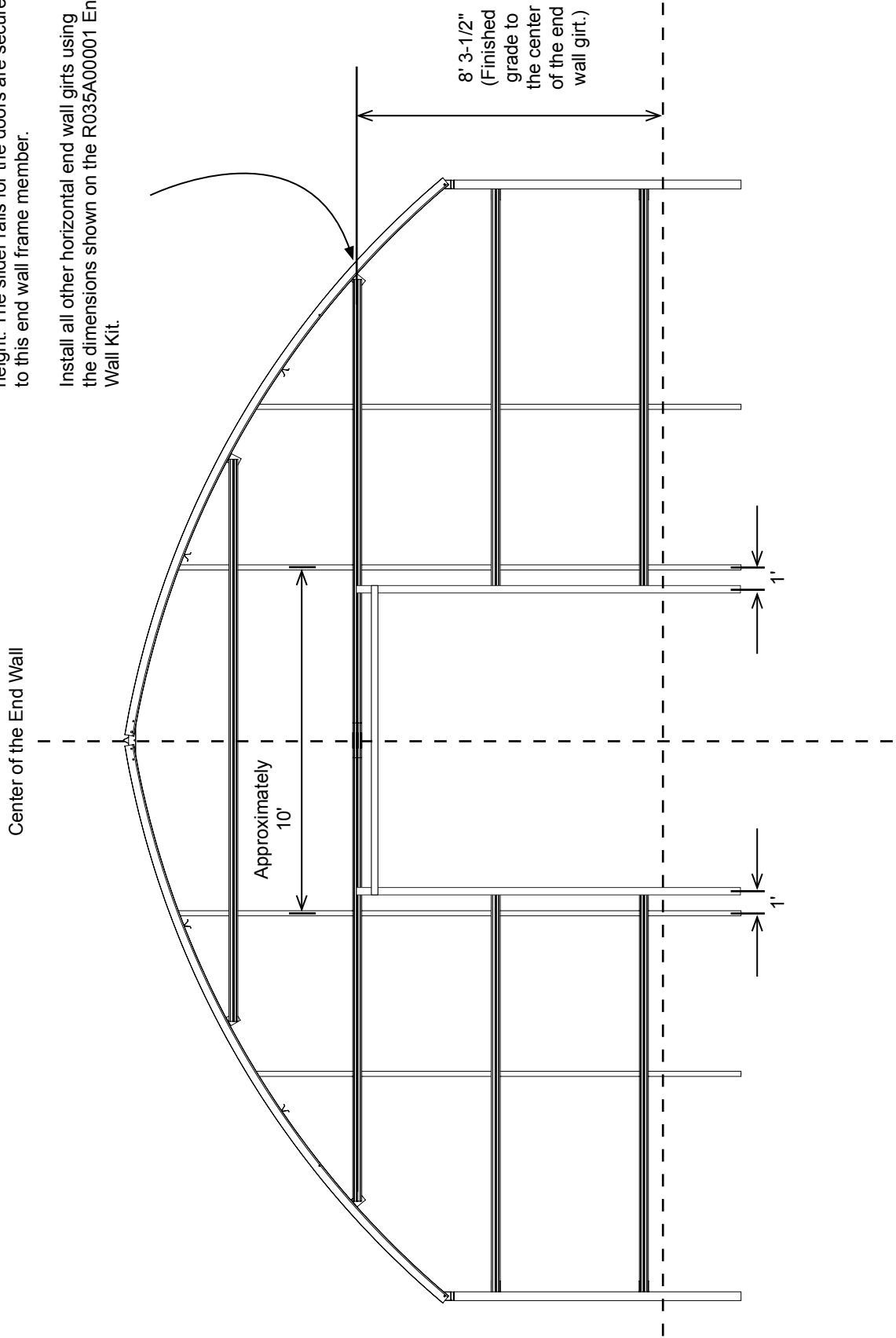

Notes



Space below is reserved for customer notes.