



## ClearSpan™ Round Style Storage Master



*Photo may show a different but similar model.*

©2008 ClearSpan™  
All Rights Reserved. Reproduction  
is prohibited without permission.

STK#	DIMENSIONS
PB00500R4	14' W x 14' H x 24' L
PB00510R4	14' W x 14' H x 28' L
PB00520R4	14' W x 14' H x 36' L

Revision date: 06.11.08



### YOU MUST READ THIS DOCUMENT BEFORE YOU BEGIN TO ASSEMBLE THE SHELTER.

Thank you for purchasing this ClearSpan™ shelter. When properly assembled and maintained, this product will provide years of reliable service. These instructions include helpful hints and important information needed to safely assemble and properly maintain the shelter. Please read these instructions **before** you begin.

If you have any questions during the assembly, contact Customer Service for assistance.

### SAFETY PRECAUTIONS

- Wear eye protection.
- Wear head protection.
- Wear gloves when handling metal tubes.
- Use a portable GFCI (Ground Fault Circuit Interrupter) when working with power tools and cords.
- Do not climb on the shelter or framing during or after construction.
- Do not occupy the shelter during high winds, tornadoes, or hurricanes.
- Provide adequate ventilation if the structure is enclosed.
- Do not store hazardous materials in the shelter.
- Provide proper ingress and egress to prevent entrapment.

### ANCHORING INSTRUCTIONS

Prior to assembling this shelter, please read the **MUST READ** document included with the shipment.

**⚠ WARNING:** The anchor assembly is an integral part of the shelter construction. Improper anchoring may cause shelter instability and failure of the structure. Failing to anchor the shelter properly *will void the manufacturer's warranty* and may cause serious injury and damage.

### LOCATION

Choosing the proper location is an important step before you begin to assemble the structure.

The following suggestions and precautions will help you determine whether your selected location is the best location.

- Never erect the structure under power lines.
- Identify whether underground cables and pipes are present *before* preparing the site or anchoring the structure.
- Location should be away from structures that could cause snow to drift on or around the building.
- Do not position the shelter where large loads such as snow and ice, large tree branches, or other overhead obstacles could fall.

### SITE

After choosing a location, proper preparation of the site is essential. Follow the information below.

- *A level site is required.* The site must be level to properly and safely erect and anchor the structure.
- For sites that are not concrete or gravel, placing wood blocks or other suitable supports under each rafter leg helps prevent the pipes from sinking or working into the site.
- Drainage: Water draining off the structure and from areas surrounding the site should drain away from the site to prevent damage to the site, the structure, and contents of the structure.

**⚠ WARNING:** The individuals assembling this structure are responsible for designing and furnishing all temporary bracing, shoring and support needed during the assembly process. For safety reasons, those who are not familiar with recognized construction methods and techniques must seek the help of a qualified contractor.

**ASSEMBLY PROCEDURE**

Following the instructions as presented will help ensure the proper assembly of your shelter. Failing to follow these steps may result in an improperly assembled and anchored shelter and will void all warranty and protection the owner is entitled.

The steps outlining the assembly process are as follows:

1. Verify that all parts are included in the shipment. Notify Customer Service for questions or concerns.
2. Read these instructions, the Must Read document, and all additional documentation included with the shipment **before** you begin assembling the shelter.
3. Gather the tools, bracing, ladders (and lifts), and assistance needed to assemble the shelter.
4. Check the weather **before** you install the roof cover and any panels (if equipped). Do not install covers or panels on a windy or stormy day.
5. Re-evaluate the location and site based on the information and precautions presented in the documentation included with the shipment.
6. Prepare the site (if applicable).
7. Assemble the frame components in the order they are presented in these instructions.
8. Assemble the frame including the struts (if equipped).
9. Consult the MUST READ document and properly anchor the assembled frame.
10. Install, tighten, and secure the end panel and main cover (if equipped). This applies to fabric covers that stretch over the frame assembly. Your shelter may include roof panels or side panels or both.
11. Read the Care and Maintenance information at the end of these instructions.

**LIST OF WORDS AND PHRASES**

Before you begin, it is important to become familiar with the words and phrases used in this instruction manual.

These words and phrases are common to most ClearSpan™ shelters and identify the different parts of the shelter. (Some are used in this document. Others may not apply to this particular shelter.) These terms describe the shipped parts and can also be found on the materials list/spec sheets included with the shipment. To aid in the assembly, read through the following definitions before you begin to assemble your shelter.

- **Conduit:** An assembly of pipes used to secure the main cover and end panels (if equipped). Purlins and some strut assemblies also consist of connected pipes to form a conduit. Each pipe joint of a conduit assembly is secured with a self-tapping Tek screw.
- **Coupler or Fitting:** A part of the frame assembly where legs, purlins and rafter pipes are inserted and secured. In most instances, 3-way and 4-way couplers are used. In some larger applications, couplers are used to secure the joints of the different rafter sections during the assembly of the rafters. Some shelters do not use couplers.
- **Foot or Rafter Foot:** The part attached to and found at the base of the rafter or leg of the shelter. Depending on the shelter, the foot is an optional purchase. Some shelters do not offer an optional foot. Some use 1-way connectors.
- **Must Read Document:** This document includes building and shelter anchoring instructions, steps for end wall reinforcement, safety precautions, and notices and warnings. The Must Read document is sent with all shelters and buildings. If you did not receive a Must Read document, contact Customer Service to request one.
- **On-Center:** Term used to describe a measurement taken from the vertical center of the rafter or frame member to the vertical center of another.
- **Purlin:** The pipe assembly that runs perpendicular to the rafters or framework that supports the main cover. Purlins are found on the sides and roof areas of the assembled frame, are evenly spaced, and typically run from the front to the back of the shelter.
- **Plain or Straight Pipe:** A term used to describe a pipe that has the same diameter or width throughout its entire length.
- **Strut:** A strut is usually a length of pipe with two flattened ends and is used for diagonal bracing of the shelter frame. A strut is typically secured to the frame work by special brackets and bolts.
- **Swaged End or Swaged Pipe:** The term “swaged” refers to the tapered end of the pipe or tube. Swaged ends of a pipe can be inserted into couplers and the straight ends of other pipes.
- **Tek Screw:** A self-tapping fastener used to secure pipe joints and to fasten brackets to rafters.

## CLEARSPAN™ GARAGES & STORAGE SHEDS

### REQUIRED TOOLS

Space below is reserved for customer notes.

The following list identifies the main tools needed to assemble the shelter. Additional tools and supports may be needed depending on the structure, location, and application.

- Tape measure or measuring device
- Fine point marker to mark the location on tubing.
- Variable speed drill and impact driver (cordless with extra batteries works best)
- Wrench, ratchet and socket (recommended)
- 1/4" Allen wrench
- Scissors
- Two ropes long enough to reach over the shelter
- Hammers and gloves
- Metal file and Metal Cutting Saw
- Duct tape (supplied by customer)
- Box cutter or utility knife
- Ladders, work platforms, and other machinery for lifting designed to work safely at the height of the shelter

### UNPACK AND IDENTIFY PARTS

The following steps will ensure that you have all the necessary parts before you begin to assemble the shelter.

1. Unpack the contents of the shipment and place where you can easily inventory the parts. Refer to the Bill of Materials/Spec Sheets.
2. Verify that all parts listed on the Bill of Materials/Spec Sheets are present. If anything is missing or you have questions, consult the Pictorial Parts Guide and all shelter diagrams for clarification, or contact Customer Service.

**NOTE:** At this time, you do not need to open the plastic bags containing smaller parts such as fasteners or washers.

### QUICK-START GUIDE

For a quick overview of this shelter and its components, consult the Quick-Start Guide at the back of these instructions.



The following graphics and photos will help you identify the different parts and show you how they are used. (Not all parts are shown.)



QH1400 & QH1402 Band Clamp



10015107 T-Fitting



CC6212 & CC6213 Fabric Clip



FA4482B Tek Screw

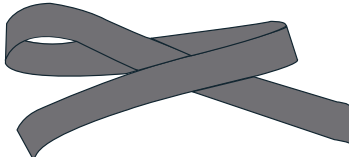

103620b Plain End Strap



102856 End Clamp



102548 Cross Connector



QH1061 Ratchet



CC2235 Zipper Extension Pole

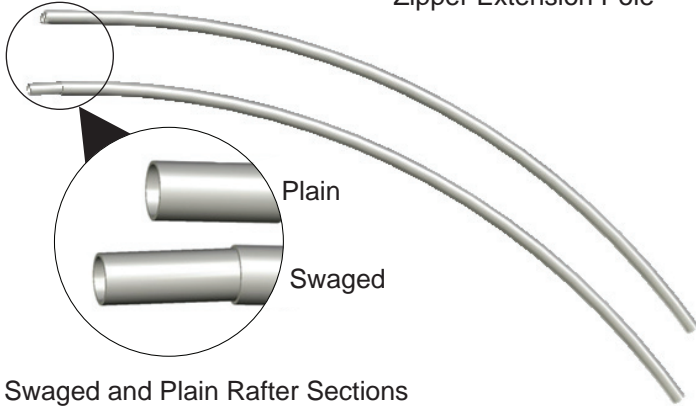

Swaged and Plain Rafter Sections (not all pieces are shown)



103395 Spin Handle

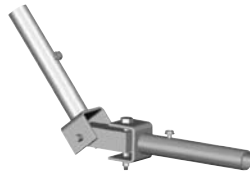

103396 Universal Joint

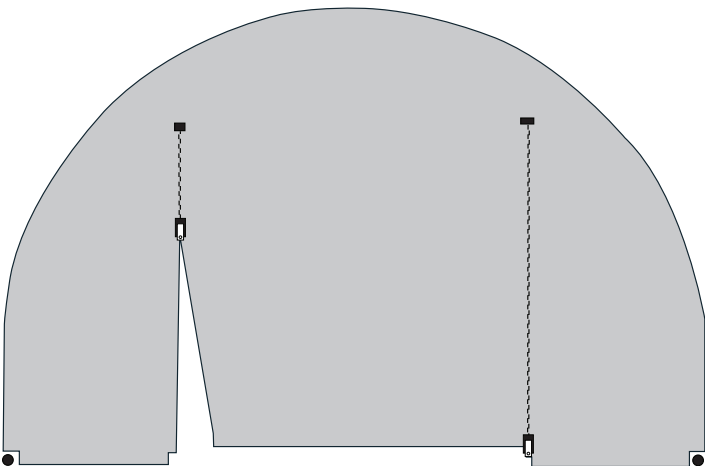

Zippered End Panel



Plain End Panel



## Round Style Storage Master

### OVERVIEW

This section is an overview of the process for assembling your Round Style Storage Master. For details, please see section, Assembling the Round Style Storage Master Components. See illustration below to identify main parts of shelter.

1. Locate the required parts for each assembly procedure.
2. Assemble the rafters and frame, and square frame.
3. Prepare end panels and insert end conduits.
4. Connect end conduits and anchor the shelter.
5. Prepare and attach end panels and main cover.

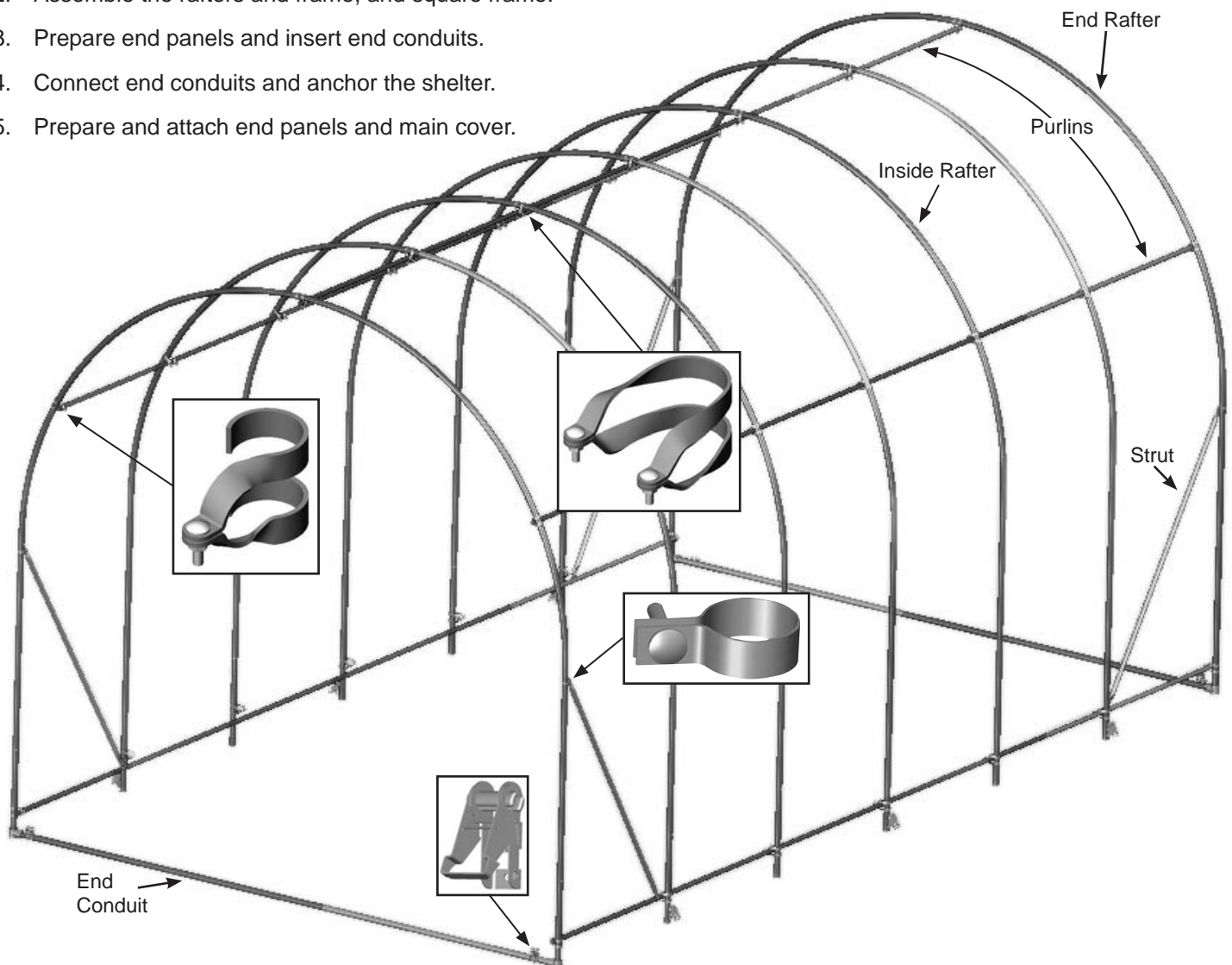

**LAY OUT THE BUILDING SITE**

After the site is prepared, identify the location of the shelter corners helps to square the frame after it is assembled.

Taking these steps **before** assembling the shelter saves time and ensures that the structure is positioned as desired. The following procedure is a suggested method. Its use depends on the size of the shelter, shelter application, the footings, and the method used to anchor the shelter.

**SQUARE THE SITE**

1. Identify a corner where a building rafter will be positioned, drive in a stake, and string a line the exact width of the building and stake in place.
2. Sting a line at least as long as the building from the first stake at 90°.

**NOTE:** A transit can be used to ensure an accurate 90° angle, or the 3-4-5 rule can be used. Refer to diagram. Using multiples of 3-4-5 such as 6-8-10 or 12-16-20 helps to maintain an accurate 90° angle.

3. After squaring the position of the building and placing a stake at all corners, string a line between the stakes to mark the base of the building.

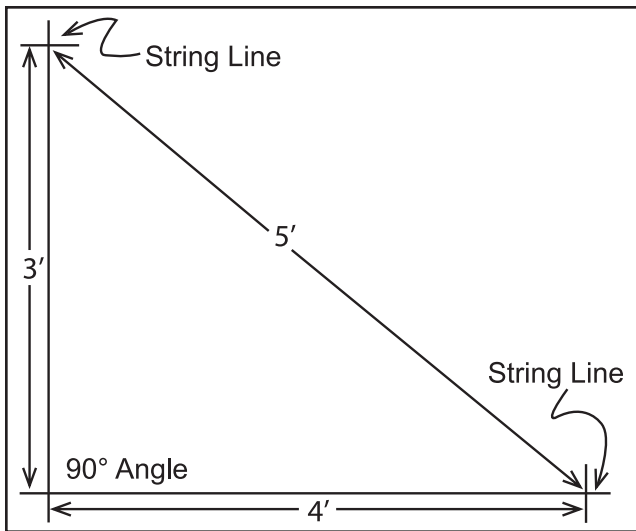

**ASSEMBLING THE ROUND STYLE STORAGE MASTER COMPONENTS**

**NOTE:** Assistance is required to assemble the shelter.

**RAFTER ASSEMBLY**

Gather the Parts:

- Round Raft Position #1 (Pipe #14R1601)
- Round Raft Position #2 (Pipe #14R1602)
- Round Raft Position #3 (Pipe #14R1603)
- 27" Leg Extension (Pipe #166S027)
- End Clamps
- Band Clamps (#QH1402)
- Tek Screws
- Nut Setter 3/8" Magnetic

Rafter Assembly Procedure:

Each rafter assembly consists of six (6) rafter sections: two (2) curved rafter pipes (for the top), two (2) side pipes that connect to the upper center pipes, and two (2) leg extension pipes.

1. Select the six (6) pipes needed to assemble a rafter and arrange these on a flat surface as shown below for assembly.

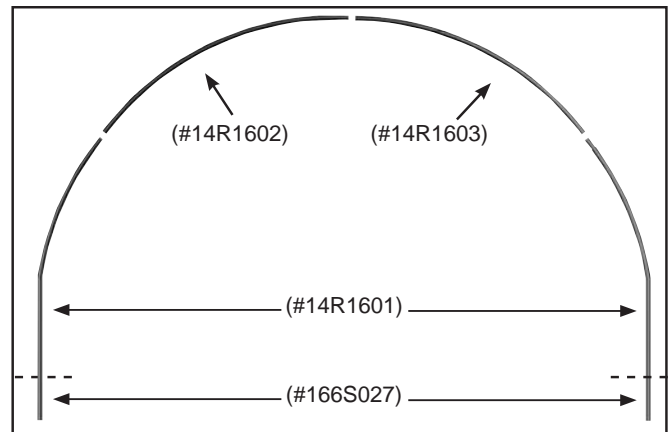

2. Slide the swaged portion of each rafter pipe into the plain end of the pipe as shown.

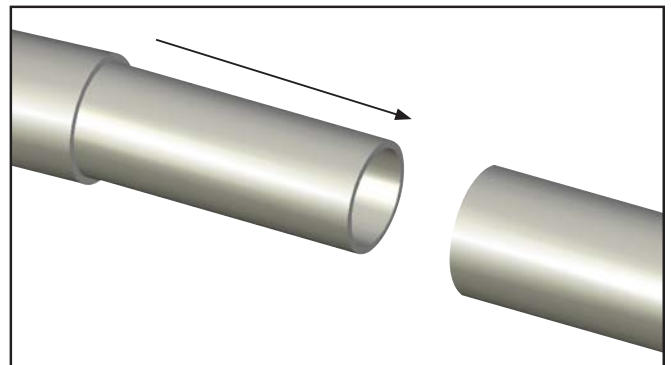

## CLEARSPAN™ GARAGES & STORAGE SHEDS

### RAFTER ASSEMBLY (CONTINUED)

3. With the main rafter pipes seated at each joint and the rafter positioned on a flat surface, secure each joint with a single self-tapping Tek screw. Position Tek screw approximately 1" from pipe joint.

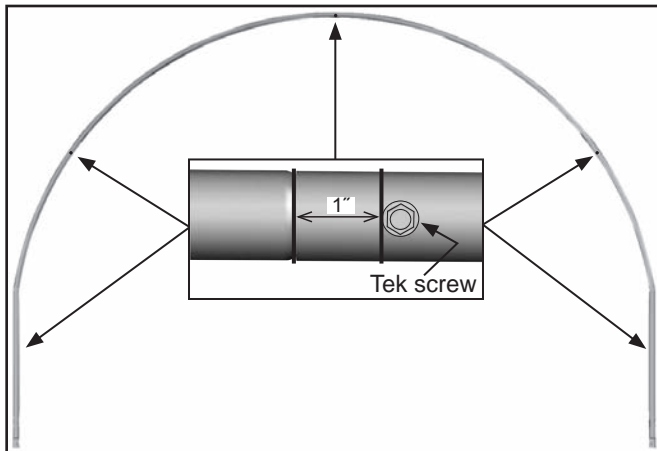

**ATTENTION:** Install the screws so they will not touch the cover once it is installed. This is typically on the backside of the rafter, which will be the surface visible from the *inside* of the shelter once the frame is assembled.

4. Assemble rafters as described and continue with the additional steps to complete the assembly of the two end rafters.

### END RAFTER ASSEMBLY

In addition to the steps in the previous procedure, complete the following steps *for the two end rafters only*.

1. Take one of the assembled rafters and place it on a flat surface.
2. Slide five (5) end clamps and two (2) band clamps onto the rafter in the locations noted below. (Do not secure the clamps to the rafter at this time. These clamps will be repositioned during the frame assembly when the purlins are added.)

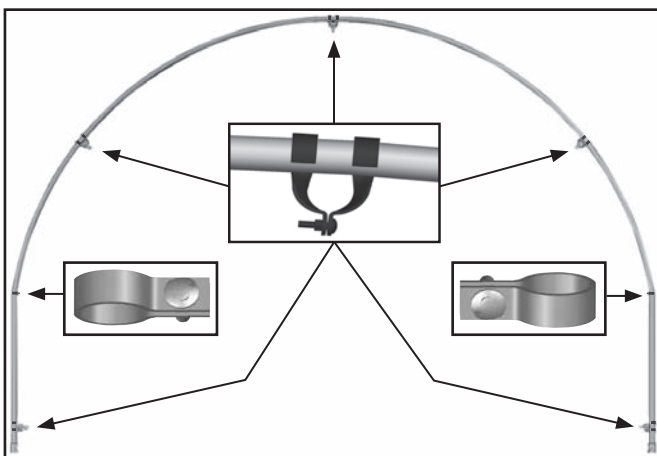

**NOTE:** All clamps must be positioned as shown. Use a piece of duct tape to keep the clamps from sliding when the rafter is set in place.

View of the end rafter and clamp as shown from the *outside* when the frame is assembled.

3. Repeat the same procedure for the final end rafter.
4. Continue with the FRAME ASSEMBLY instructions that follow.

**FRAME ASSEMBLY**

Gather the Parts

- All Rafter Assemblies
- Pipe 1.315" x 75" Swaged 17GA
- Pipe 1.315" x XX" Plain 17GA
- Strut 5'
- Band Clamps (#QH1400)

Frame Assembly Procedure:

1. Stand one end rafter (one with the end clamps attached) and brace it in place as shown below. Check that the rafter is standing up straight (plumb). Position the bolt side of end clamp to the inside of the frame

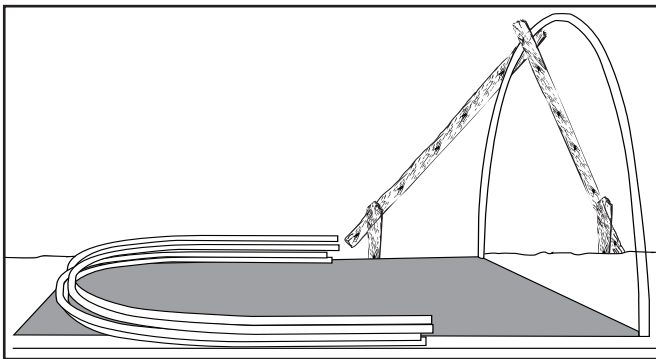

2. Insert the plain end of one 75" purlin pipe into each end clamp at the bottom of the end rafter.

**CAUTION:** To prevent cover damage, the ends of the purlins should extend no more than 1/2" past the end clamp. The bolt side of the end clamps must go toward the "inside" of the shelter (the same side as the purlin) as shown below.

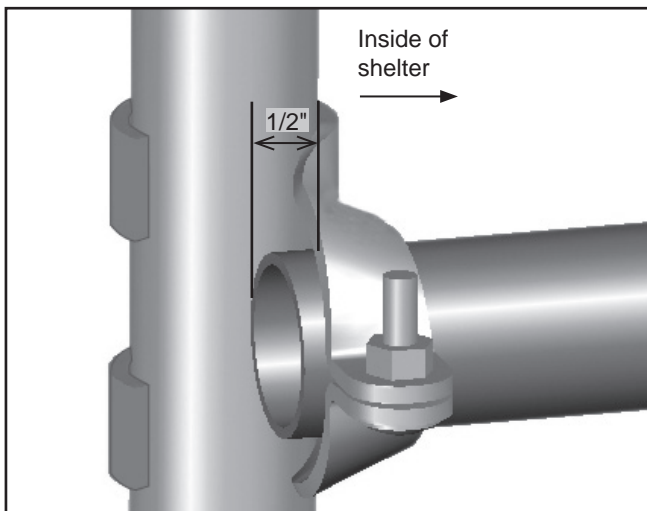

3. Position an inside rafter from the end rafter using an on-center, rafter-to-rafter spacing of 4'. (Another person is required to hold the rafter in position.)

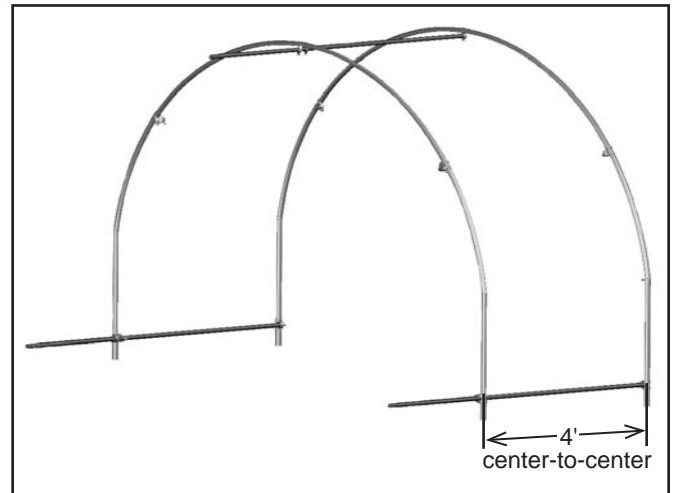

4. Install a cross connector and insert the purlin pipe through the connector at the top of the interior rafter and also through the end clamp at the top of the end rafter.
5. Verify that both rafters are plumb and properly spaced (4' on center).

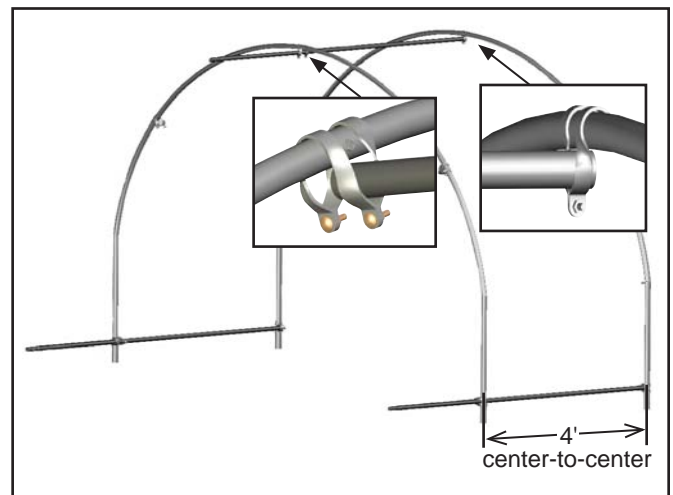

6. Tighten the cross connector at the top of the interior rafter and tighten the end clamp at the top of the end rafter.

## CLEARSPAN™ GARAGES & STORAGE SHEDS

### FRAME ASSEMBLY (CONTINUED)

7. Move to the lower end of the rafters and position the purlin 4-6" up from the finished grade.

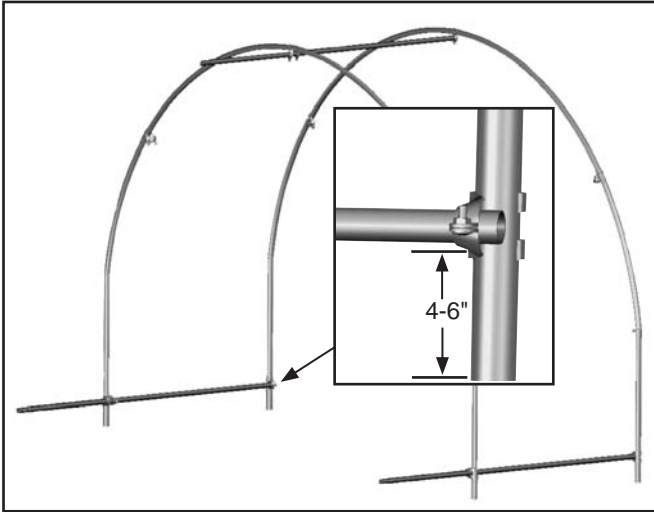

8. Install the remaining purlins. Verify the rafter spacing is 4' on-center and tighten connectors.

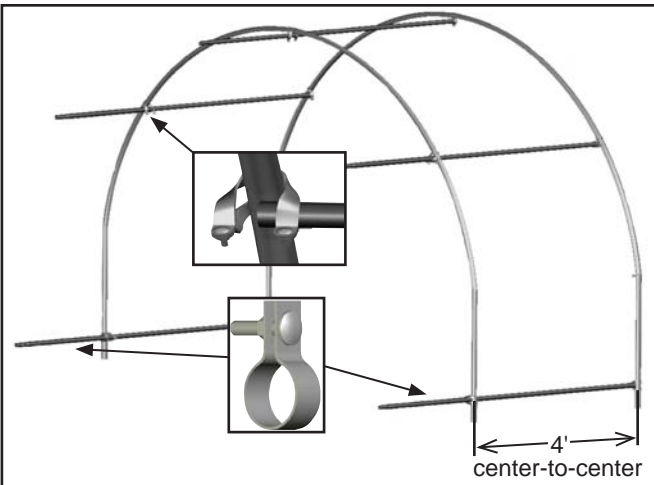

9. Slide a band clamp onto each bottom purlin after the second rafter to prepare for the strut assembly.
10. Continued adding rafters and purlins until the frame is assembled. Remember to add band clamps to the lower purlins between the second and third rafter at the remaining end of the frame for the installation of the struts.

**NOTE:** Each purlin assembly consists of 1.315" x 75" (#131S075) swaged pipes (number is determined by shelter length) and one (1) 1.315" x XX" (#131P0XX) plain pipe.

The XX" represents the remaining length needed to reach the end of the frame. Consult the Spec Sheet for part identification.

11. Finish each purlin run using the plain, shorter pipe (#131P0XX), and use the final end rafter to complete the assembly.

**NOTE:** If the last end rafter is plumb and the purlin run extends beyond the end of the rafter, cut the last section of purlin pipe to the required length.

Typically purlin pipes *do not* require cutting. *Verify that you have finished the purlin run with the correct plain pipe before you decide to cut any pipe.*

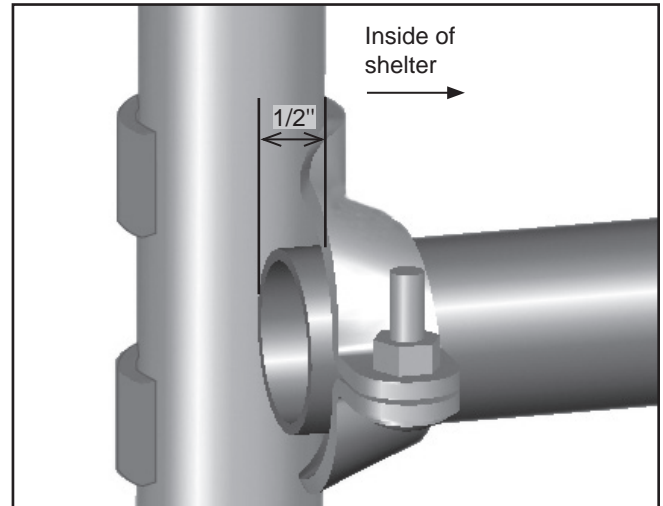

**CAUTION:** To prevent cover damage, the ends of the purlins should extend no more than 1/2" past the end clamp. The bolt side of the end clamps must go toward the "inside" of the shelter (the same side as the purlin) as shown.

12. Return to each clamp and install a Tek screw through the clamp and into the purlin pipe as shown.
13. Secure each clamp to the rafter using a Tek screw.

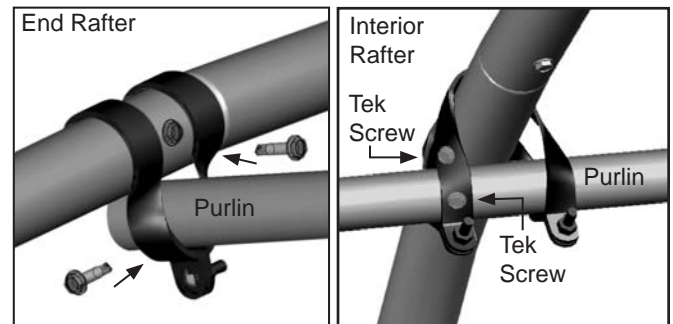

**Strut Assembly Procedure:**

1. After the rafter assembly is complete, verify that the band clamps are in the proper location. See diagram below.

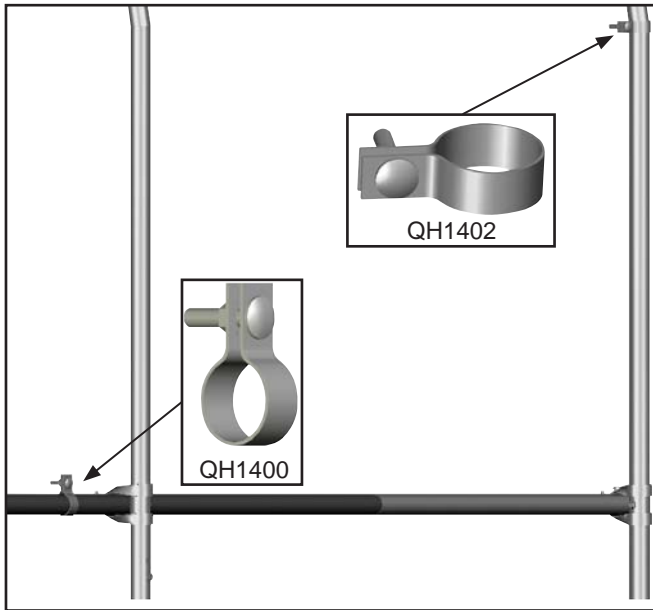

2. Remove the bolts and attach a strut between the band clamp on the purlin and the band clamp on the end rafter. Position the strut so that it forms a triangle as shown below.

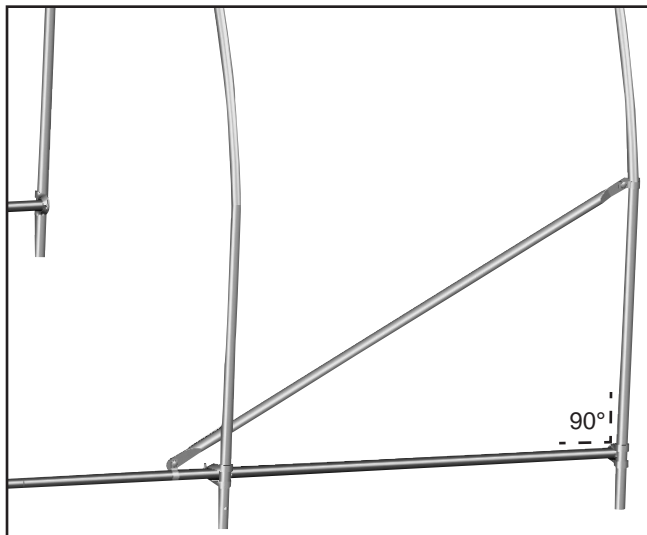

**NOTE:** Verify that the bolt heads are to the outside of the shelter and that the end rafter is plumb before tightening the nuts.

3. Install the remaining struts and tighten all band clamp bolts.
4. Secure each band clamp to each purlin or rafter with a Tek screw.
5. Return to each purlin joint and secure using a Tek screw.

**SQUARE THE ASSEMBLED FRAME**

**Gather the Parts**

- Measuring tape
- Tek Screws

**Complete these steps:**

1. Square the frame by measuring diagonally corner-to-corner, and align all rafters as shown below.
2. Verify that the width of each rafter is 14' center-to-center.

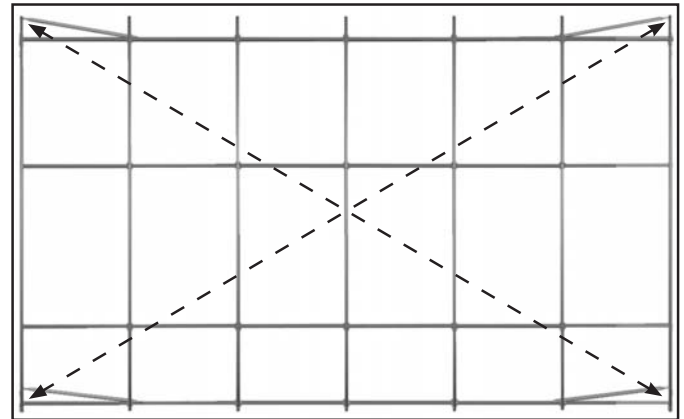

FRAME TOP VIEW

**NOTE:** The frame is square when the two diagonal measurements are the same.

3. Tape all rafter splices with duct tape to protect the main cover when it is installed.
4. Verify that all pipe splices and clamps are secured using Tek screws.

**FINISH ROUGH EDGES**

**Gather the Parts**

- Duct tape (supplied by customer)
- Metal file (may not be needed)

1. Check for any sharp edges on the frame and file them smooth so they will not cut the cover.
2. Apply two layers of heavy duct tape on all pipe connections and clamps that may contact the cover.

## CLEARSPAN™ GARAGES & STORAGE SHEDS

### END CONDUIT ASSEMBLIES

Gather the Parts:

- Pipe 1.66" x 99" Swaged (2)
- Pipe 1.66" x 72" Plain (2)
- T-fitting 1" and Tek Screws
- Duct Tape and Metal Cutting Saw

Assembly Procedure:

1. Locate the end conduit pipes and T-fittings. Each end conduit consists of one (1) 99" pipe, one (1) 72" pipe (cut to 70-1/2"), and two (2) T-fittings. Two (2) end conduits are required.

**NOTE:** To maintain the 14' width, cut the 72" plain pipe to 70-1/2".

2. Assemble an end conduit by connecting the 99" swaged pipe to the 70-1/2" plain pipe and secure the joint using a Tek screw. Tape over the Tek screw to protect the end panel. Repeat the steps to assemble the remaining end conduit.

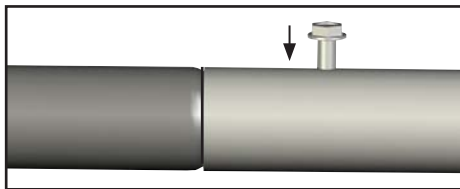

3. Add the T-fittings at the ends of the conduits and tighten the Allen screws.

**NOTE:** Do not insert the end conduit pipes all the way into the T-fittings, but instead allow room for the end rafter to be inserted later.

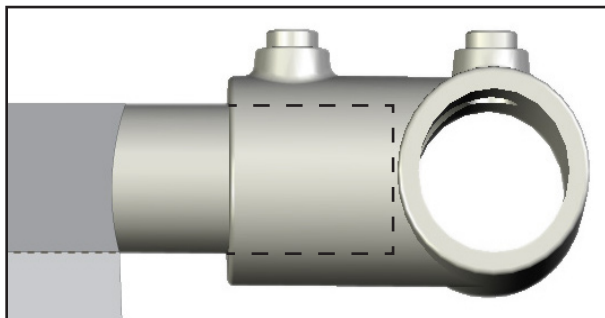
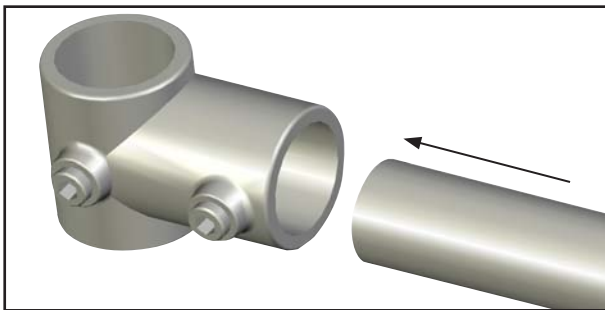

### PREPARE END PANELS

**CAUTION:** To prevent damage, do not install end panels on a windy day.

Gather the Parts:

- End Panel Solid (Plain)
- End Panel 2-Zip (Zippered)
- End Conduit Assemblies (2)
- Scissors

Assembly Procedure:

1. If the corners of the end panels have not been cut out, follow this procedure:
  - a. Lay an end panel out on a clean flat surface.
  - b. Place the end conduit assembly centered side-to-side on top of the hem.
  - c. With scissors, trim the corner of the end panel on the dotted line shown below so the T-fitting is exposed when conduit is placed inside the hem.
  - d. Repeat the same steps for the other end of this end panel and for both ends of the remaining end panel.



2. Remove one T-fitting from the end conduit assembly and slide the end conduit assembly into the hem at the bottom of the solid (plain) end panel. Replace the T-fitting that was removed.
3. On the zippered end panel, insert the end conduit through the two side panels of the end panel (as shown below) and not through the door section.

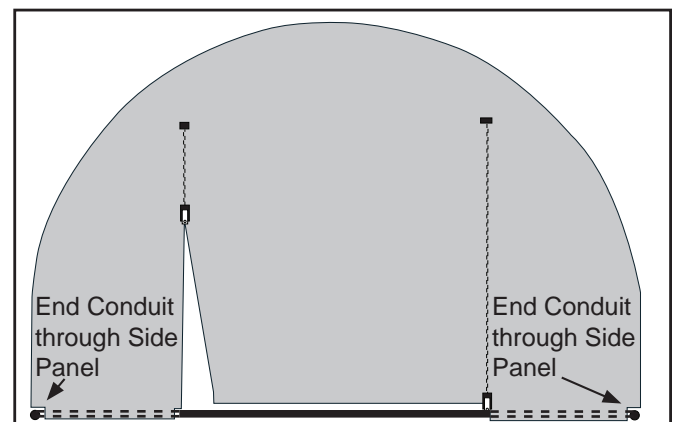

**ATTACH END CONDUIT ASSEMBLIES**

1. Verify the end conduits of end panels are inserted into the T-fittings correctly.

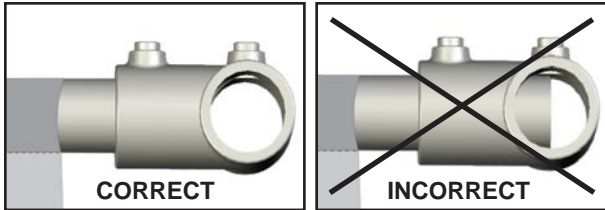

**ATTENTION:** Do not allow the end conduit to extend into the opening that remains for the bottom of the end rafters.

2. Insert the bottom of the end rafters into the T-fitting of the end conduit.
3. Verify that the rafter pipe is flush with the bottom of the T-fitting.
4. Tighten the Allen screws to secure the T-fitting to the end rafter and end conduit.

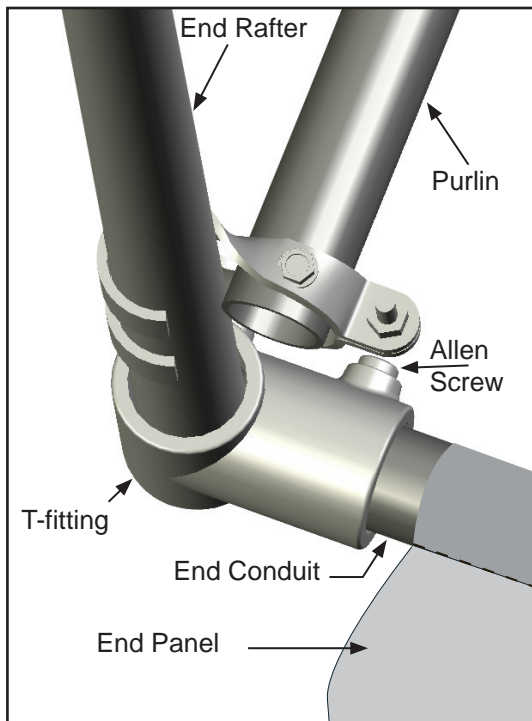

**ANCHOR THE SHELTER**

At this point, anchor the shelter. Consult the MUST READ document for anchoring information and suggestions. Please call customer service at 1-800-245-9881 for additional anchoring information.

**⚠ CAUTION:** The anchor assembly is an integral part of the shelter construction. Improper anchoring may cause shelter instability and failure of the structure to perform as designed. Failing to anchor the shelter properly will void the manufacturer's warranty and may cause serious injury and damage.

**ATTACH END PANEL ASSEMBLIES**

Gather the Parts:

- End Panel Assemblies
- Fabric Clips #CC6213 (Divide clips equally for both end panels; save four to six (4-6) clips for roll-up crank assembly.)
- Tek Screws
- Measuring Tape
- Scissors

Assembly Procedure:

1. While standing inside the shelter, start at the peak of the end rafter and pull the solid (plain) end panel over the top of the rafter so the material edge is on the inside of the rafter.
2. Secure the solid end panel in place at the top center of end rafter with a fabric clip and Tek screw.
3. Moving outward in both directions, place fabric clips spaced evenly on rafter.
4. Secure each fabric clip to end rafter with a Tek screw (on side where it will not contact cover).

**NOTE:** The end panels may be shipped as untrimmed rectangular pieces. If so, use scissors to trim the excess end panel material inside the shelter to an inch or two past the fabric clip as shown below.

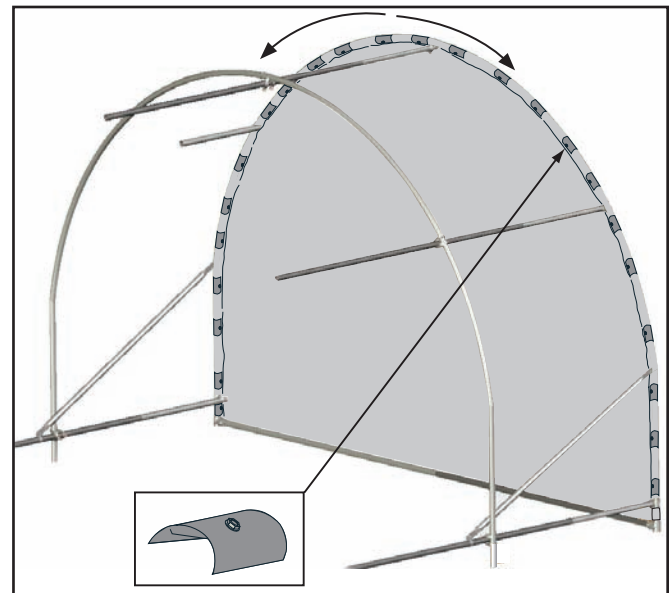

5. Secure the zippered end panel in place using fabric clips and Tek screws as completed on the plain end panel.

## CLEARSPAN™ GARAGES & STORAGE SHEDS

### INSTALL ROLL-UP CRANK ASSEMBLY

Gather the Parts:

- Pipe 1.315" x 75" Swaged (2)
- Pipe 1.315" x 49.5" Plain (2)
- Zipper Extension Pole (#CC2235)
- Spin Handle
- Universal Joint
- Fabric Clips (#CC6212) (4-6)

Assembly Procedure:

1. Assemble the roll-up door conduit by connecting one (1) 75" swaged pipe to the 49.5" plain pipe, secure the joint using a Tek screw, and tape over the Tek screw to protect the end panel.
2. Insert the conduit assembly into the door pocket. When installed correctly, the conduit is flush at one end of the roll-up panel and will extend an inch or so beyond the other end of the panel where the crank will be attached.
3. Secure the conduit to the panel using fabric clips as shown below.

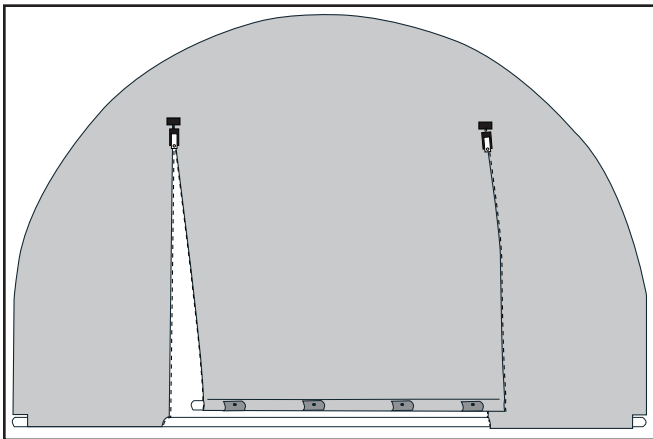

4. Attach the universal joint to the conduit in the pocket using a Tek screw to secure the connection.

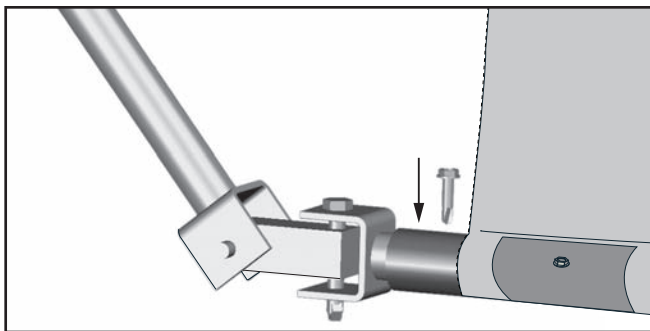

5. To assemble the extension pipe, connect the remaining 49.5" plain pipe and 75" swaged pipe and secure the joint using a Tek screw.
6. Secure the extension pipe to the remaining end of the universal joint using a Tek screw.

**NOTE:** The extension pipe can be trimmed to the desired length if needed.

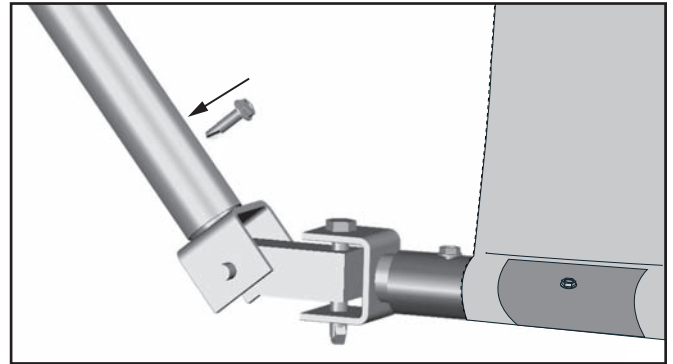

7. Add the spin handle to the extension pole and secure the connection with a Tek screw.



The roll-up crank assembly is now complete and is shown below. Extension pipe may differ in length.

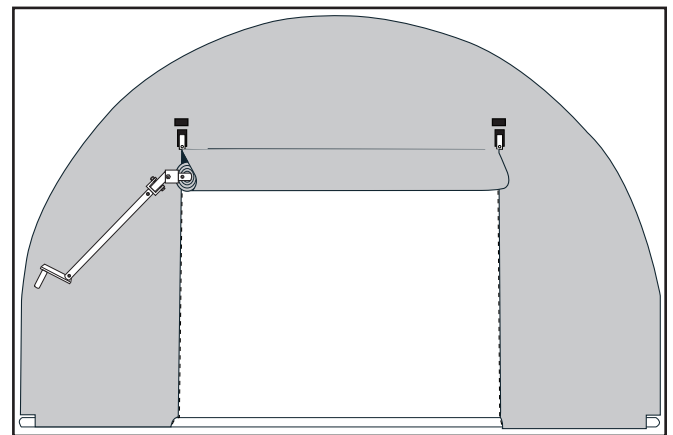

**NOTE:** Use the zipper extension pole to zip and un-zip tall zipper doors.

Do not open the door panel until the shelter is completely assembled and anchored.

**PREPARE MAIN COVER**

Gather the Parts:

- Ratchets (1" 4000lb)
- Pipe 1.315" x 75" Swaged
- Pipe 1.315" x XX" Plain
- Cover
- Tek Screws

Assembly Procedure:

**NOTE:** When handling the main cover and setting it in position, do not pull on the end straps. They will pull out of the cover.

**⚠ WARNING:** To prevent damage to the cover and to prevent serious personal injury, **DO NOT** attempt to install the main cover on windy days.

1. Fasten a ratchet to the end conduit with a Tek screw in the bottom hole of the ratchet as shown below. The ratchet should be about 6" in from the end of the conduit. Repeat this step in all four corners.

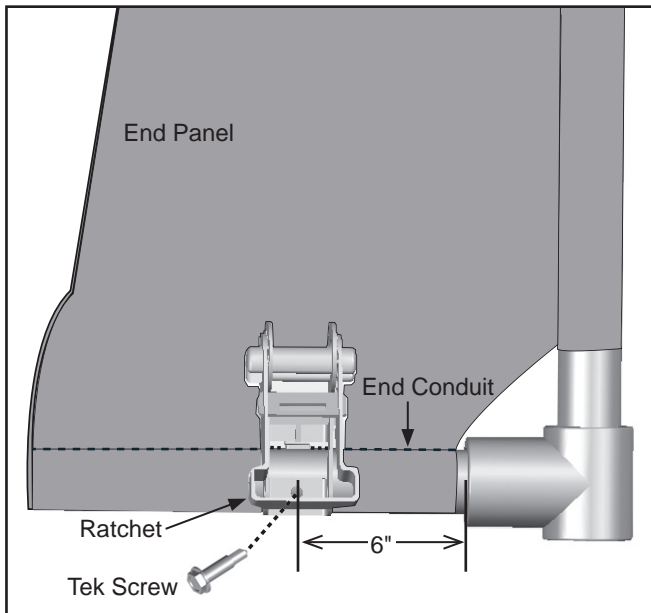

2. Assemble two main cover conduits. Start each conduit assembly with one plain pipe and add swaged pipes to arrive at the correct length. *This conduit is identical to the purlins that are attached to the frame.*
  - a. Locate all sections of pipe needed to assemble the cover conduit.
  - b. Insert the swaged end of each pipe into the plain end of another pipe until the conduit is assembled.
  - c. Secure each pipe joint with a Tek screw.

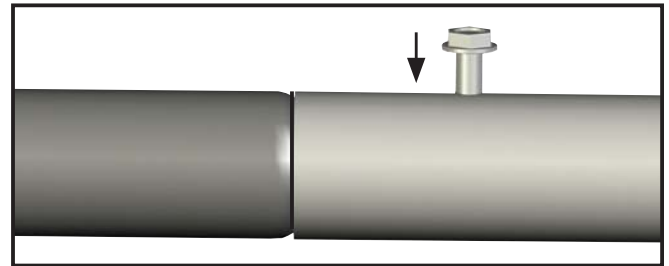

**NOTE:** Duct tape Tek screws to prevent damage to main cover.

These cover conduits are inserted into the pockets sewn into the main cover. The conduits are used to tighten and secure the main cover.

3. After assembling the cover conduits, locate the main cover and unfold it on a clean, smooth surface near the frame.

**NOTE:** Unfold the main cover with the inside surface facing up.

4. Locate the cover ends with strapping and align with the front and back of the shelter.
5. Insert the cover conduits into the pockets of the main cover.

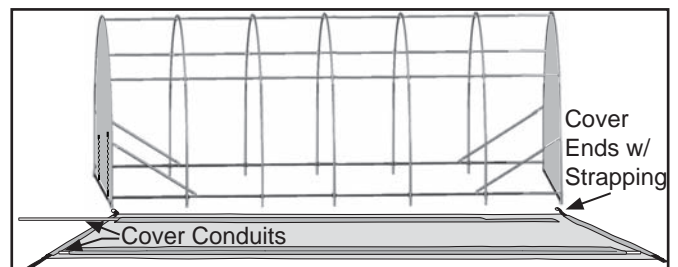

**NOTE:** Shelter shown above may be a different length than this model.

## CLEARSPAN™ GARAGES & STORAGE SHEDS

### ATTACH MAIN COVER

Gather the Parts:

- Main cover (with conduits already inserted)
- Ropes long enough to reach over the frame (provided by customer).
- Ratchets (1" 4000lb)
- Tek screws
- Box cutter or utility knife

Assembly Procedure:

1. To pull the cover over the frame, attach ropes to both ends of the cover conduit. Wrap the rope around the conduit a few times to prevent it from slipping off.

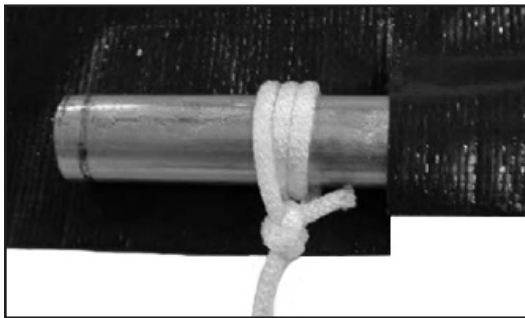

**NOTE:** Depending on the length of the cover it may be necessary to attach additional ropes to the cover conduit between the end ropes by cutting a small opening in the cover pocket and tying the rope around the conduit. **DO NOT** cut through the main cover. *Cut through the conduit pocket only.*

2. With all ropes attached to the cover conduit, lift the conduit and carry the cover toward the base of the frame.
3. Toss the ropes over the frame and pull the cover into position. One person is required at each rope.

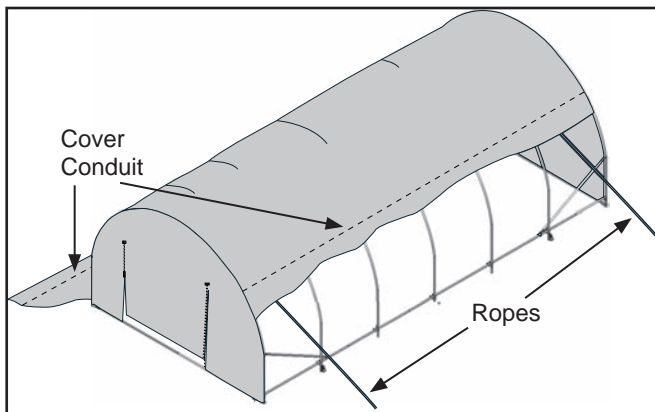

4. Once the main cover is pulled into position, center the cover on the frame and remove the ropes. Loosely secure the ends of the cover to the ratchets attached to the front and back end panel conduits.

**ATTENTION:** Do not tighten the straps at this time

5. Divide the remaining number of ratchets in half. Place the ratchets on the ground next to the rafter where they will be attached.

**NOTE:** Ratchets are evenly spaced long each side of the shelter and directly across from each other on the *same rafter assembly*. Rafters are identified by the arrows below.

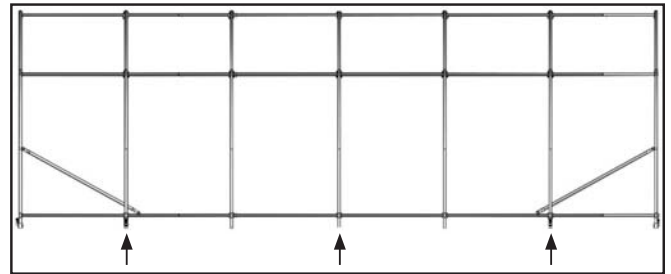

**NOTE:** Diagram above is an example of the 24' shelter.

6. Using the main cover conduit as a guide, attach the ratchets to the rafters at the proper height. Fasten ratchets to the outside of these rafters using a Tek screw.

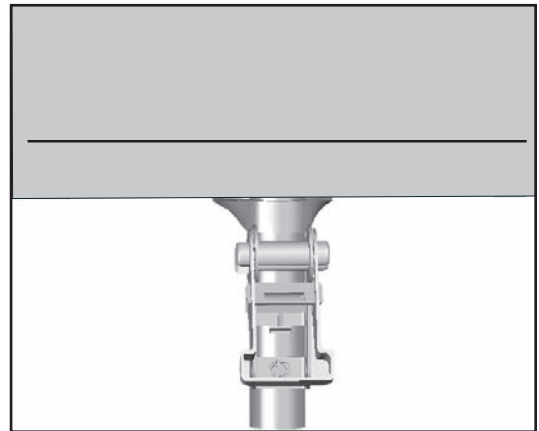

7. Lift the cover skirt and cut a slit in the cover conduit pocket at the rafter position. Insert a 3' section of strap through the slit and around the cover conduit.

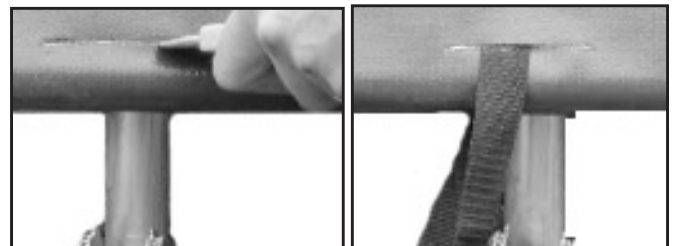

**NOTE:** **DO NOT** cut through the main cover. *Cut through the conduit pocket only.*

**ATTACH MAIN COVER (CONTINUED)**

8. Thread the strap ends into the ratchet and slightly tighten.

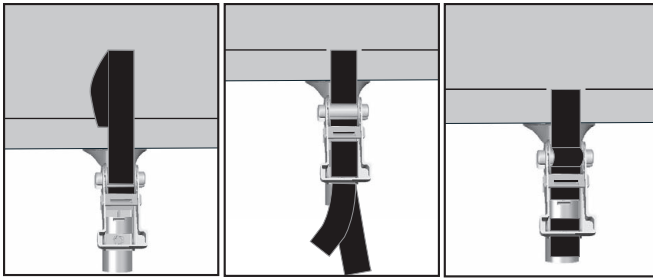

**NOTE:** It may be necessary to remove excess strap if it binds up in the ratchet.

9. Repeat the steps for the remaining ratchets.
10. Using additional help (if needed) tighten the main cover beginning with the ratchets along the side of the shelter frame.
11. After the side ratchets are tightened, return to the front and back end wall ratchets and tighten.

**NOTE:** Loosen the ratchets if needed to remove excess strap and retighten. Loosen all ratchet if needed to reposition the main cover on the frame and retighten the ratchets.

12. Fold the skirt of main cover down and over the ratchets to complete the installation of the main cover.

**SHELTER CARE AND MAINTENANCE**

Proper care and maintenance of your shelter is important. Check the following items periodically to properly maintain your shelter:

- Regularly check the main cover and panels (if equipped) to see that these remain tight and in proper repair.
- Check connections and all fasteners to verify that they remain tight.
- Do not climb or stand on the shelter at anytime.
- Remove debris and objects that may accumulate on the shelter. Use tools that will not damage the cover when removing debris.
- Remove snow to prevent excess accumulation. Use tools that will not damage the cover when removing snow.
- Check the contents of the shelter to verify that nothing is touching the cover or the side panels that could cause damage.
- Check the anchoring system to ensure that all components are tight and in good repair.
- If the shelter is moved, inspect all parts and connections before reassembling.
- For replacement or missing parts, call 1-800-245-9881 for assistance.

**NOTE:** With the exception of Truss Arch buildings, ClearSpan™ shelters and greenhouses do not have any tested loading criteria.



**QUICK START GUIDE**

14' Wide Round Style Storage Master

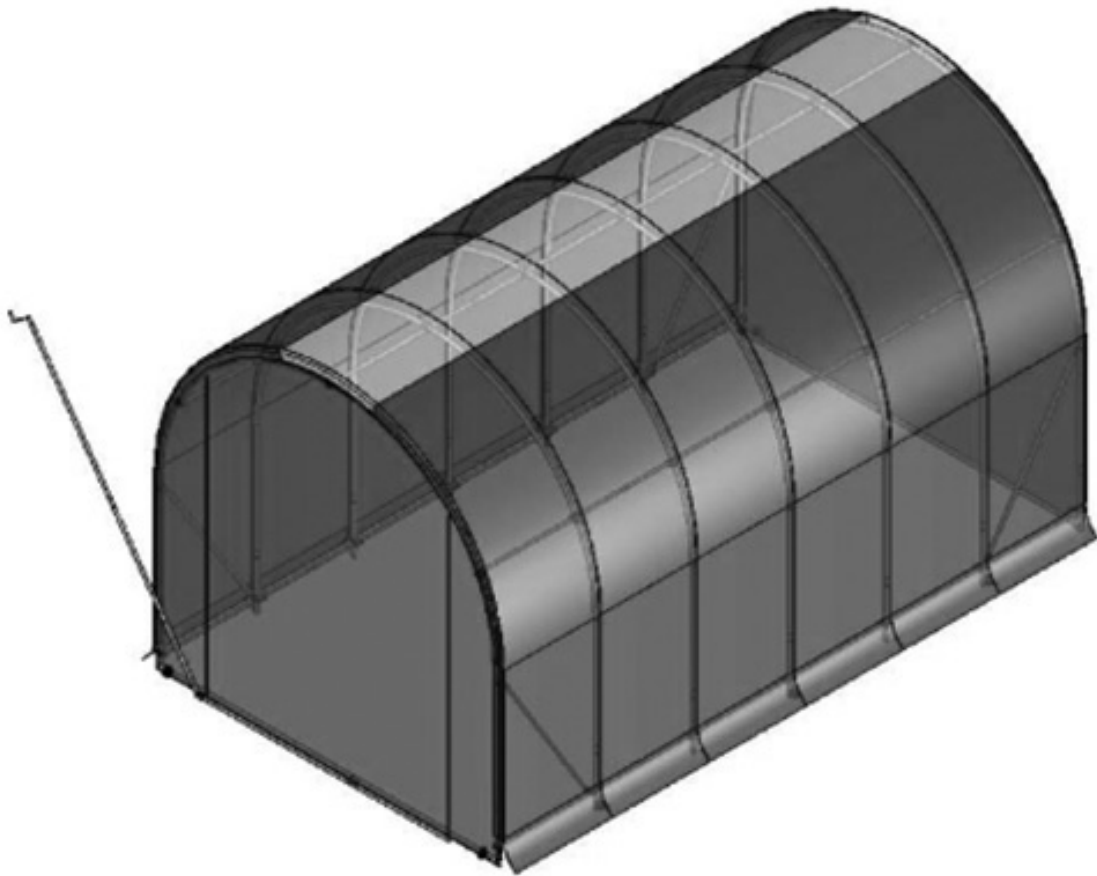

Frame shown may differ in length from actual frame.

# FRONT PROFILE

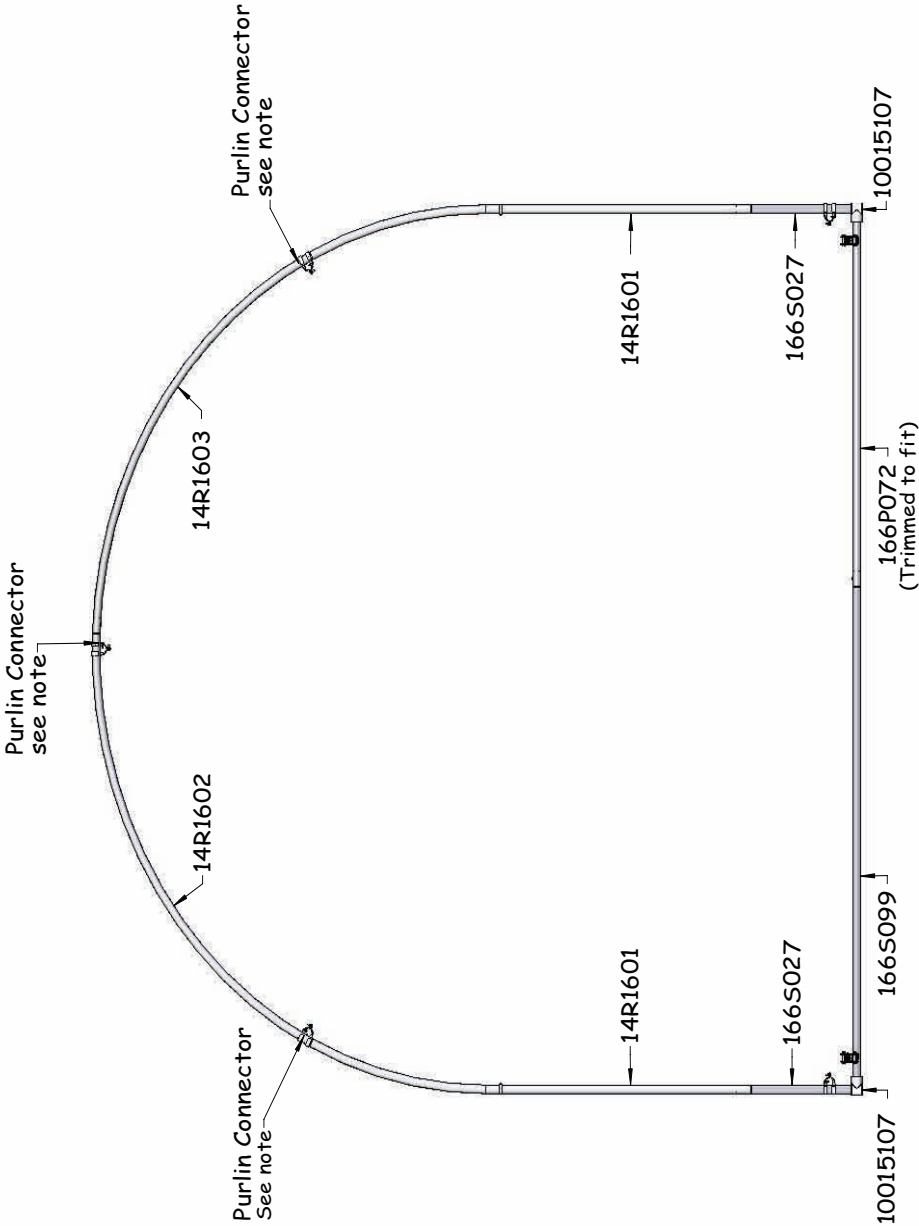

Connection Note  
Purlin connected to end rafters using 102856 clamp - See View 1  
Purlin connected to mid rafters using 102548 cross connector - See View 3

End Conduit and associated hardware only used on end rafters





# SIDE PROFILE - PB0520R4N

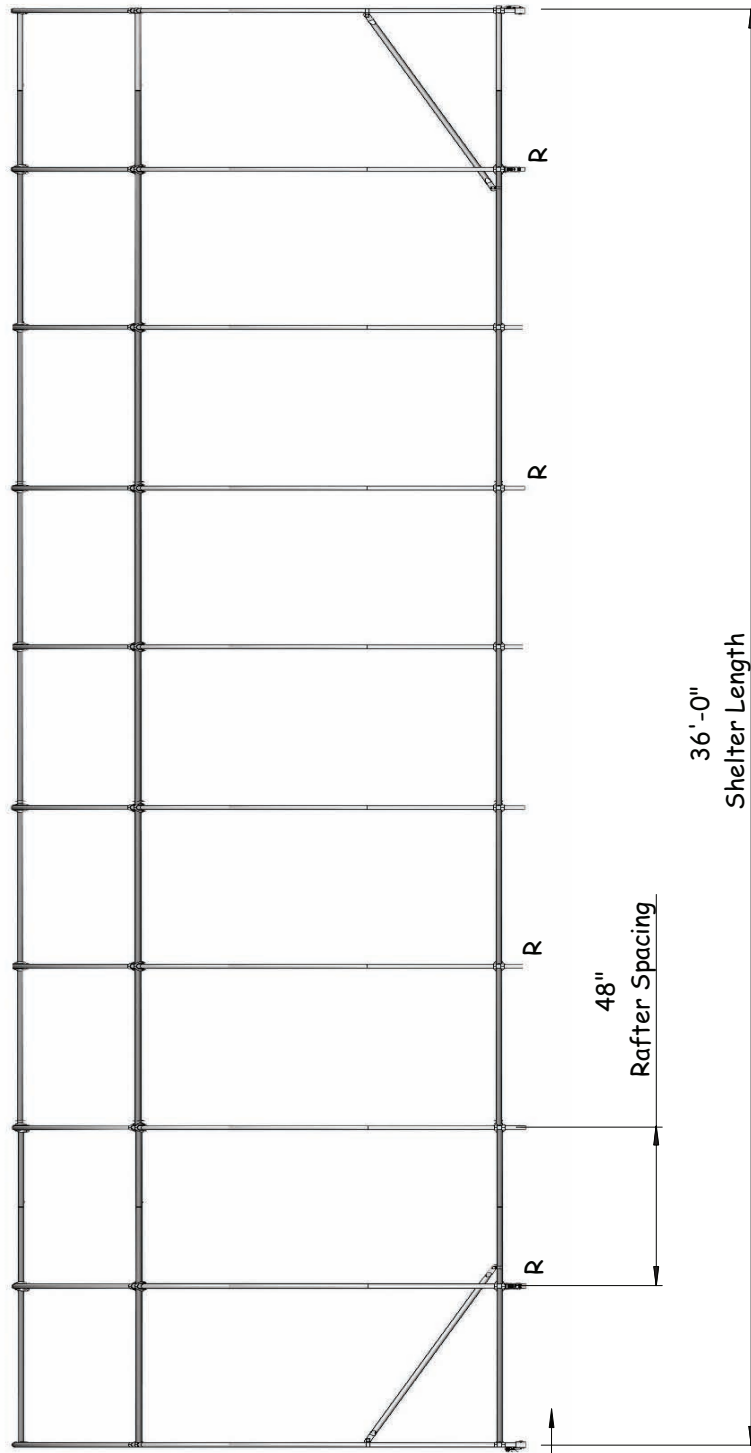

Ratchets secured to rafters indicated with R  
 Note: ratchets on opposite

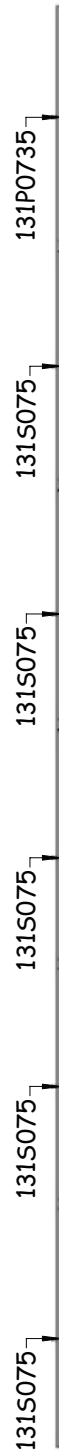

# CONNECTIONS

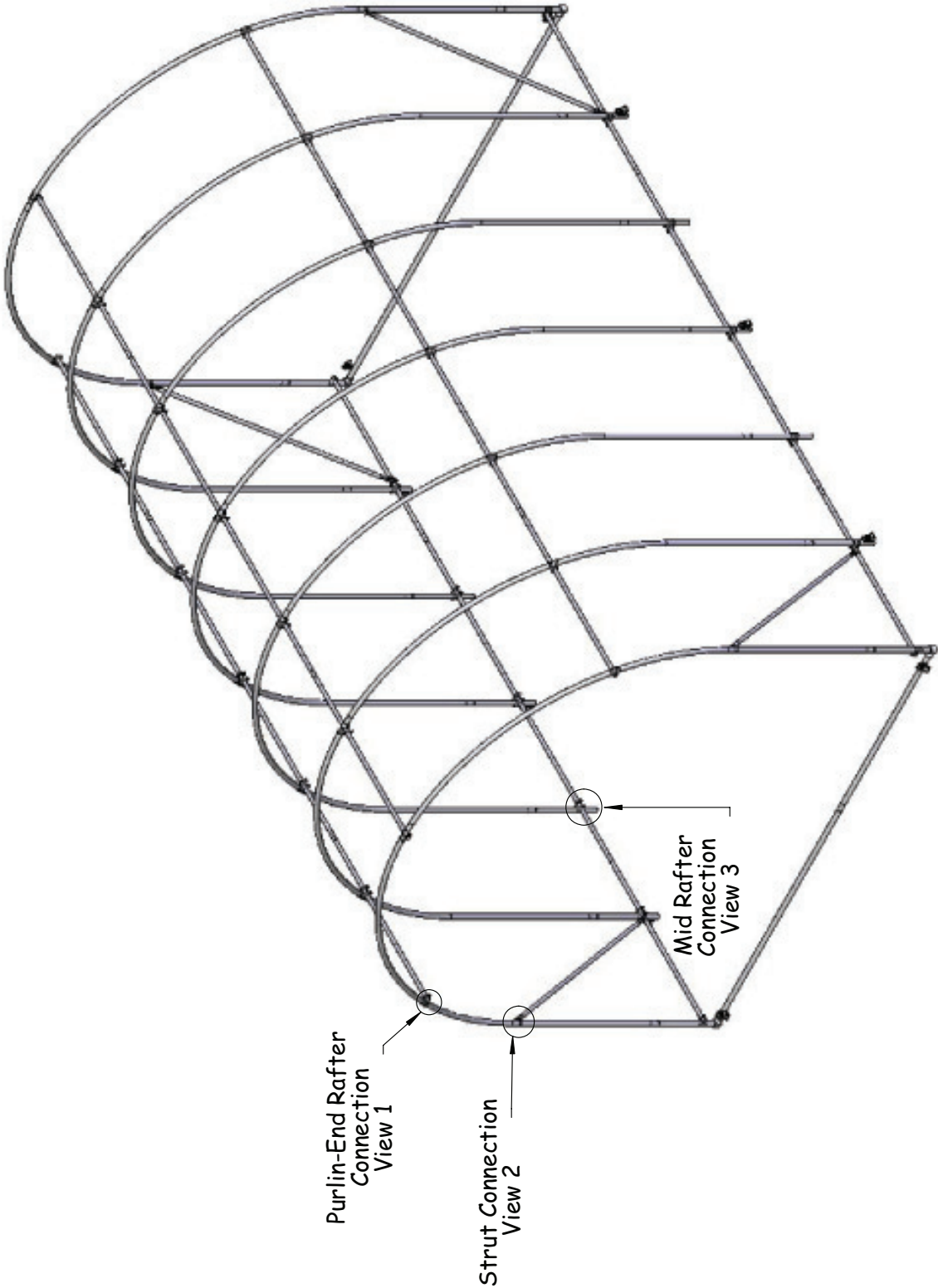

# CONNECTION - DETAILS

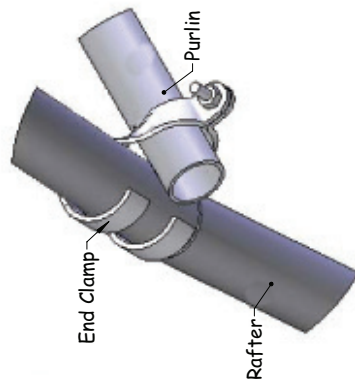

**View 1**  
**Purlin-End Rafter Connection**

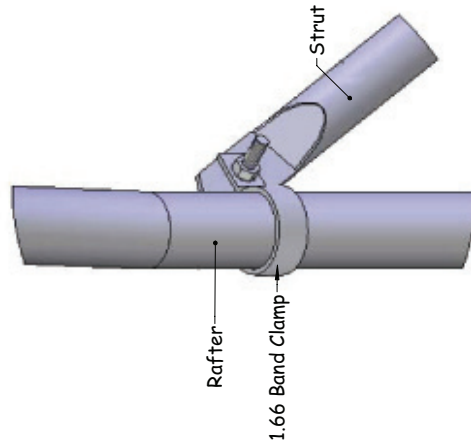

**View 2**  
**Strut Connection**

Opposite end of strut connected to bottom purlin run in similar fashion using a 1.315 band clamp.

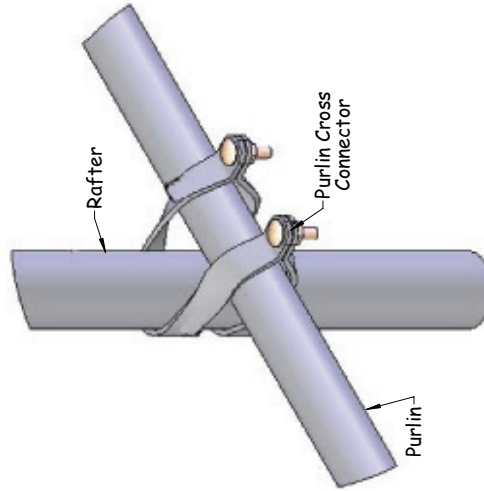

**View 3**  
**Purlin-Mid Rafter**



Space below is reserved for customer notes.