

FarmTek®

WeatherShield Commercial Canopies



Photo may show a different but similar model.

©2023 FarmTek®
All Rights Reserved. Reproduction
is prohibited without permission.



WARNING: Cancer and Reproductive Toxicity - P65Warnings.ca.gov

STK#	DIMENSIONS
1820CC	18' W x 20' L
1830CC	18' W x 30' L
1840CC	18' W x 40' L
1850CC	18' W x 50' L
1860CC	18' W x 60' L

Revision date: 02.27.23

FarmTek®

YOU MUST READ THIS DOCUMENT BEFORE YOU BEGIN TO ASSEMBLE THE SHELTER.

Thank you for purchasing this FarmTek® shelter. When properly assembled and maintained, this product will provide years of reliable service. These instructions include helpful hints and important information needed to safely assemble and properly maintain the shelter. Please read these instructions **before** you begin.

If you have any questions during the assembly, contact Customer Service for assistance.

SAFETY PRECAUTIONS

- Wear eye protection.
- Wear head protection.
- Wear gloves when handling metal tubes.
- Use a portable GFCI (Ground Fault Circuit Interrupter) when working with power tools and cords.
- Do not climb on the shelter or framing during or after construction.
- Do not occupy the shelter during high winds, tornadoes, or hurricanes.
- Provide adequate ventilation if the structure is enclosed.
- Do not store hazardous materials in the shelter.
- Provide proper ingress and egress to prevent entrapment.

ANCHORING INSTRUCTIONS

Prior to assembling this shelter, please read the **MUST READ** document included with the shipment.

⚠ WARNING: The anchor assembly is an integral part of the shelter construction. Improper anchoring may cause shelter instability and failure of the structure. Failing to anchor the shelter properly *will void the manufacturer's warranty* and may cause serious injury and damage.

LOCATION

Choosing the proper location is an important step before you begin to assemble the structure.

The following suggestions and precautions will help you determine whether your selected location is the best location.

- Never erect the structure under power lines.
- Identify whether underground cables and pipes are present *before* preparing the site or anchoring the structure.
- Location should be away from structures that could cause snow to drift on or around the building.
- Do not position the shelter where large loads such as snow and ice, large tree branches, or other overhead obstacles could fall.

SITE

After choosing a location, proper preparation of the site is essential. Follow the information below.

- *A level site is required.* The site must be level to properly and safely erect and anchor the structure.
- For sites that are not concrete or gravel, placing wood blocks or other suitable supports under each rafter leg helps prevent the pipes from sinking or working into the site.
- Drainage: Water draining off the structure and from areas surrounding the site should drain away from the site to prevent damage to the site, the structure, and contents of the structure.

⚠ WARNING: The individuals assembling this structure are responsible for designing and furnishing all temporary bracing, shoring and support needed during the assembly process. For safety reasons, those who are not familiar with recognized construction methods and techniques must seek the help of a qualified contractor.

ASSEMBLY PROCEDURE

Following the instructions as presented will help ensure the proper assembly of your shelter. Failing to follow these steps may result in an improperly assembled and anchored shelter and will void all warranty and protection the owner is entitled.

The steps outlining the assembly process are as follows:

1. Verify that all parts are included in the shipment. Notify Customer Service for questions or concerns.
2. Read these instructions, the Must Read document, and all additional documentation included with the shipment **before** you begin assembling the shelter.
3. Gather the tools, bracing, ladders (and lifts), and assistance needed to assemble the shelter.
4. Check the weather **before** you install the roof cover and any panels (if equipped). Do not install covers or panels on a windy or stormy day.
5. Re-evaluate the location and site based on the information and precautions presented in the documentation included with the shipment.
6. Prepare the site (if applicable).
7. Assemble the frame components in the order they are presented in these instructions.
8. Assemble the frame including the struts (if equipped).
9. Consult the MUST READ document and properly anchor the assembled frame.
10. Install, tighten, and secure the main cover and panels (if equipped). This applies to fabric covers that stretch over the frame assembly. Your shelter may include roof panels or side panels or both.
11. Read the Care and Maintenance information at the end of these instructions.
12. Complete and return all warranty information as instructed.

LIST OF WORDS AND PHRASES

Before you begin, it is important to become familiar with the words and phrases used in this instruction manual.

These words and phrases are common to most FarmTek® shelters and identify the different parts of the shelter. (Some are used in this document. Others may not apply to this particular shelter.) These terms describe the shipped parts and can also be found on the materials list/spec sheets included with the shipment. To aid in the assembly, read through the following definitions before you begin to assemble your shelter.

- **Conduit:** An assembly of pipes used to secure the main cover and end panels (if equipped). Purlins and some strut assemblies also consist of connected pipes to form a conduit. Each pipe joint of a conduit assembly is secured with a self-tapping Tek screw.
- **Coupler or Fitting:** A part of the frame assembly where legs, purlins and rafter pipes are inserted and secured. In most instances, 3-way and 4-way couplers are used. In some larger applications, couplers are used to secure the joints of the different rafter sections during the assembly of the rafters. Some shelters do not use couplers.
- **Foot or Rafter Foot:** The part attached to and found at the base of the rafter or leg of the shelter. Depending on the shelter, the foot is an optional purchase. Some shelters do not offer an optional foot. Some use 1-way connectors; some use ground posts.
- **Must Read Document:** This document includes building and shelter anchoring instructions, steps for end wall reinforcement, safety precautions, and notices and warnings. The Must Read document is sent with all shelters and buildings. If you did not receive a Must Read document, contact Customer Service to request one.
- **On-Center:** Term used to describe a measurement taken from the vertical center of the rafter or frame member to the vertical center of another.
- **Purlin:** The pipe assembly that runs perpendicular to the rafters or framework that supports the main cover. Purlins are found on the sides and roof areas of the assembled frame, are evenly spaced, and typically run from the front to the back of the shelter.
- **Plain or Straight Pipe:** A term used to describe a pipe that has the same diameter or width throughout its entire length.
- **Strut:** A strut is usually a length of pipe with two flattened ends and is used for diagonal bracing of the shelter frame. A strut is typically secured to the frame work by special brackets and bolts.
- **Swaged End or Swaged Pipe:** The term “swaged” refers to the tapered end of the pipe or tube. Swaged ends of a pipe can be inserted into couplers and the straight ends of other pipes.
- **Tek screw:** A self-tapping fastener used to secure pipe joints and to fasten brackets to rafters.

COMMERCIAL CANOPIES

REQUIRED TOOLS

The following list identifies the main tools needed to assemble the shelter. Additional tools and supports may be needed depending on the structure, location, and application.

- Tape measure or measuring device
- Variable speed drill and impact driver (cordless with extra batteries works best)
- Wrenches or ratchet and socket set (recommended)
- Two ropes long enough to reach over the shelter (The use of rope depends on the height of the shelter. Other main cover installation methods may not use rope.)
- Hammers, gloves and eye protection
- Magnetic nut setter (3/8" x 2-9/16") - supplied by customer
- Duct tape (supplied by customer)
- Box cutter or utility knife
- Ladders, work platforms, and other machinery for lifting designed to work safely at the height of the shelter

UNPACK AND IDENTIFY PARTS

The following steps will ensure that you have all the necessary parts before you begin to assemble the shelter.

1. Unpack the contents of the shipment and place where you can easily inventory the parts. Refer to the Bill of Materials/Spec Sheets.
2. Verify that all parts listed on the Bill of Materials/Spec Sheets are present. If anything is missing or you have questions, consult the Pictorial Parts Guide and all shelter diagrams for clarification, or contact Customer Service.

NOTE: At this time, you do not need to open the plastic bags containing smaller parts such as fasteners or washers.

QUICK START GUIDE

For an overview of this shelter and to see the main connection details, consult the diagrams in the Quick Start Guide located at the back of these instructions.

ALTERNATIVE ASSEMBLY INFORMATION

These instructions describe assembling the entire roof section of the shelter first. The frame is then lifted and the legs added. For long shelters or when limited assistance is available, constructing the frame and legs in sections suitable for lifting and moving and working from one end to the other is an alternative assembly method. (This method is not shown.)

To assembly the frame in sections, read these instructions first and adapt the steps as needed. Consult all diagrams and the Quick Start section of this manual to better understand how the frame is assembled before you begin. Install the main cover as a single unit after the frame is assembled and anchored.

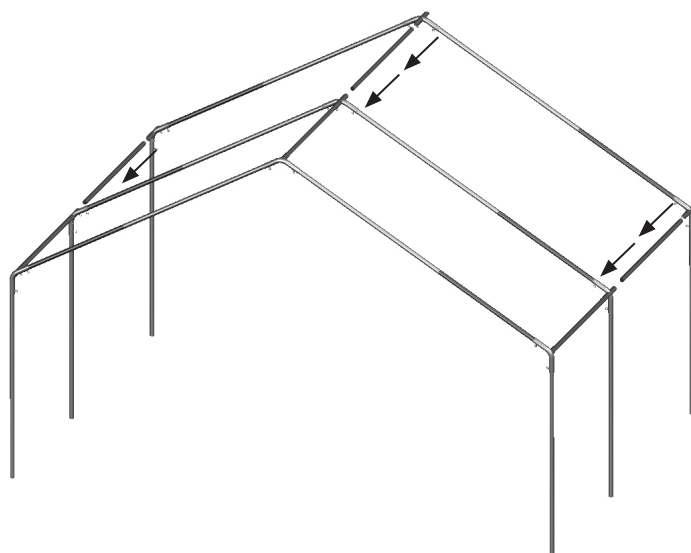

FarmTek®

The following graphics and photos will help you identify the different parts and show you how they are used.
(Not all parts are shown.)



FA4482B
Tek screw



FAMF01B
Fender Washer



QH1061
Ratchet

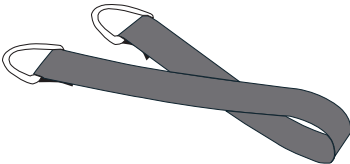

102947
D-ring Strap

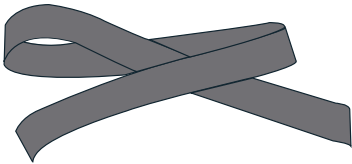

103620b
Plain End Strap



102193
3-Way Coupler



102194
4-Way Coupler

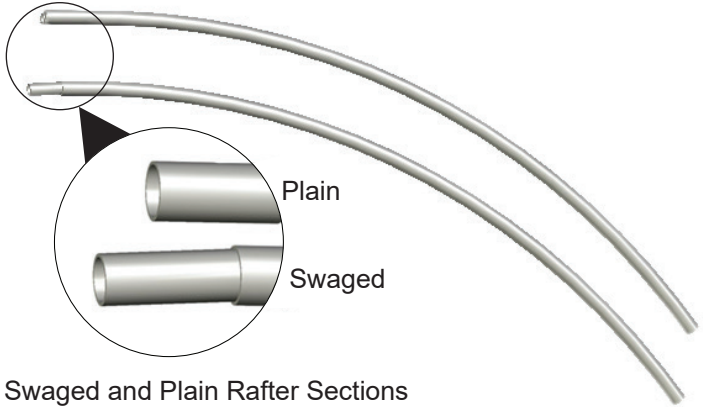

Swaged and Plain Rafter Sections
(not all pieces are shown)

COMMERCIAL CANOPIES

ADDITIONAL PARTS IDENTIFICATION NOTES

In some instances, there can be differences between the parts that are shown and referenced in the instructions and the parts that are shipped with the shelter. These differences *do not* affect the integrity of the shelter, but can change the assembly procedures.

The information that follows identifies possible changes in the assembly procedure found in this instruction document. *Please implement these changes during the assembly of the shelter.*

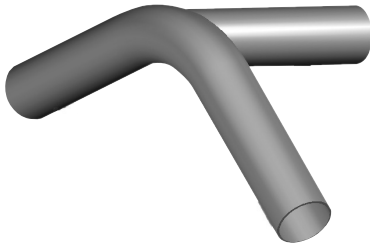

3-Way Coupler (no lock bolt)



3-Way Coupler (includes lock bolt)



4-Way Coupler (no lock bolt)

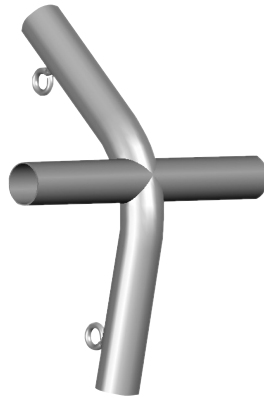

4-Way Coupler (includes lock bolt)

There can be two types of couplers used during the assembly of the shelter: those that include an installed locking eyebolt and those that do not. See above.

If the couplers included with your shelter do not have an installed lock bolt, use a *self-tapping Tek screw* to secure the different pipes to the couplers during the assembly process. The self-tapping Tek screws are included with the shipment.

ATTENTION: Tek screws are sent with all shelters of this type. For couplers with locking eyebolts, install the Tek screws at each pipe connection for additional security if desired.

⚠ WARNING: To prevent personal injury and damage to the shelter, *fasten and tighten a Tek screw* at each pipe and coupler joint.

To prevent cover damage, install the Tek screw so that it *does not* touch the main cover or any optional side or end panels once these are installed.



WeatherShield Commercial Canopies

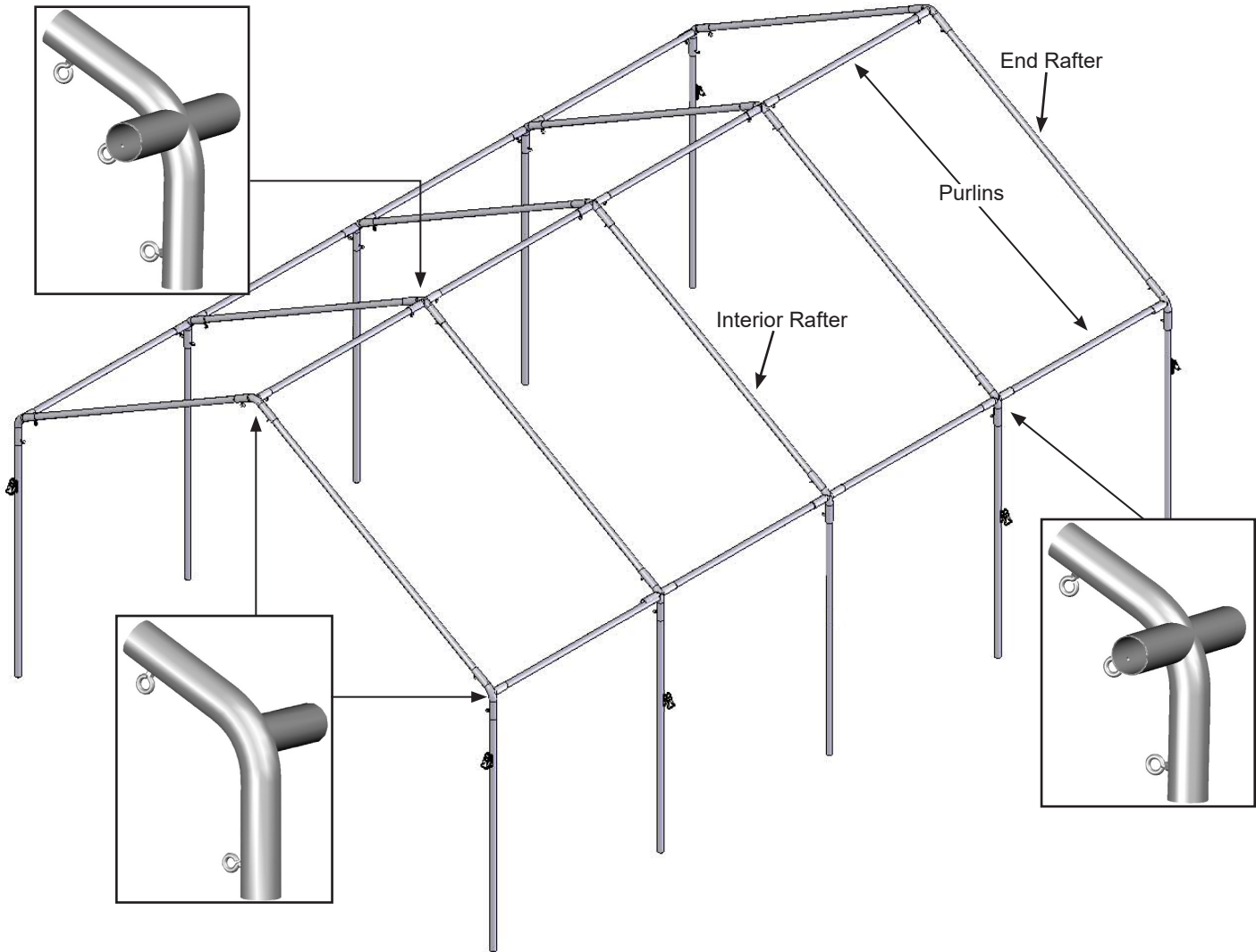

FRAME DIAGRAM

NOTE: Diagram above may show a shelter that differs in length or width from the actual frame. The use and positions of ratchets may also differ from actual shelter. Frame above is used for illustration purposes.

COMMERCIAL CANOPIES

LAY OUT THE BUILDING SITE

After the site is prepared, identify the location of the shelter corners to help square the frame after it is assembled.

Taking these steps **before** assembling the shelter saves time and ensures that the structure is positioned as desired. The following procedure is a suggested method. Its use depends on the size of the shelter, shelter application, the footings, and the method used to anchor the shelter.

SQUARE THE SITE

1. Identify a corner where a building rafter will be positioned, drive in a stake, and string a line the exact width of the building and stake in place.
2. Sting a line at least as long as the building from the first stake at 90°.

NOTE: A transit can be used to ensure an accurate 90° angle, or the 3-4-5 rule can be used. Refer to diagram. Using multiples of 3-4-5 such as 6-8-10 or 12-16-20 helps to maintain an accurate 90° angle.

3. After squaring the position of the building and placing a stake at all corners, string a line between the stakes to mark the base of the building.

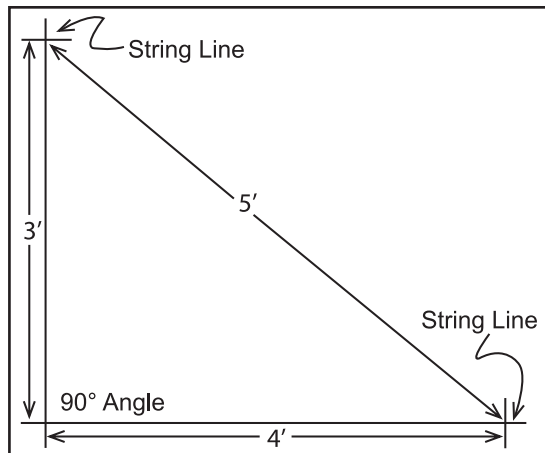

FRAME ASSEMBLY

NOTE: With longer shelters, assembly may require shelter to be assembled in short sections and then lifted and connected for completion.

Gather the parts:

- Pipes 1.66" x 68" plain (166P068)
- Pipes 1.66" x 77" plain (166P077)
- Pipes 1.66" x 51" swaged (166S051)
- 3-way couplers and 4-way couplers
- Tek screws (#FA4482B)

Frame Assembly Procedure

Arrange the roof pipes on the ground adjacent to the correct couplers needed to assemble the roof.

1. Connect the ridge pipes (58" purlin section) using a 3-way coupler on the end rafter and 4-way couplers for the interior the sections. The assembled length should match the shelter length.

NOTE: The last ridge pipe will finish with a 3-way coupler. Verify that the correct pipe is used.

2. Attach the rafter pipes as shown in the illustration. Each rafter is assembled using one (1) 68" plain pipe and one (1) 51" swaged pipe using a Tek screw to secure the joint for each side of the rafter.

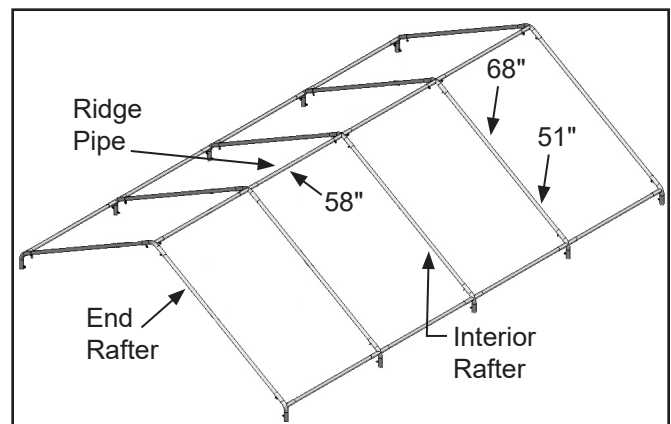

3. Connect the 3-way couplers to form the end rafters of the roof assembly and connect the 4-way cross couplers to construct the interior rafters.

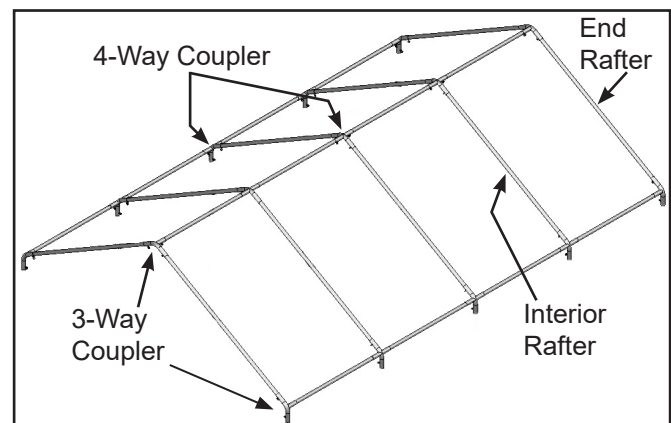

NOTE: Position the eye bolts of the couplers to the inside of the frame and tighten.

FRAME ASSEMBLY (CONTINUED)

4. While lifting one side of the assembled roof structure, insert a 77" pipe into the 3-way and 4-way couplers then tighten eye bolts. Refer to the illustration below.

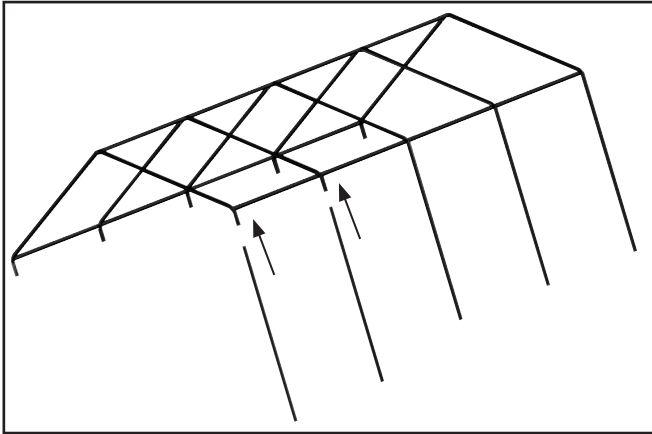

5. Repeat the step for the other side of the frame.
6. Verify that all eye bolts are tight and square the frame.

SQUARE THE ASSEMBLED FRAME

Gather the parts

- Measuring tape and assistants

Complete these steps:

1. With the frame in position, perform a final square of the frame by measuring diagonally (corner-to-corner) as shown below at the bottom of the legs. Verify that the two measurements are equal and adjust if needed.

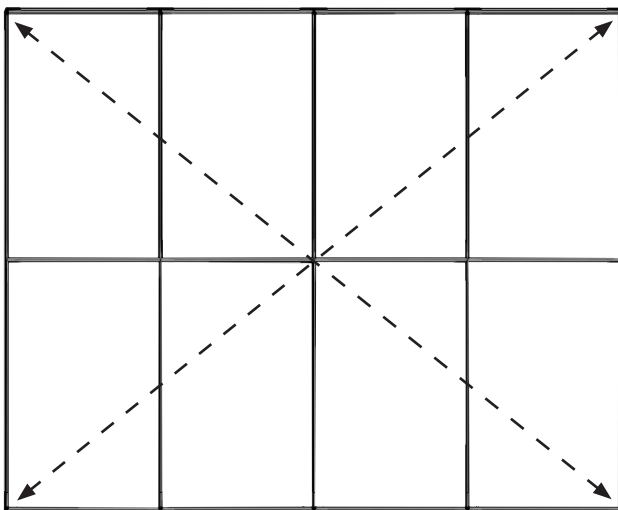

FRAME TOP VIEW

2. Measure width from center of rafter leg to center of other rafter leg of the same rafter assembly and adjust if needed. Repeat for all rafter assemblies.

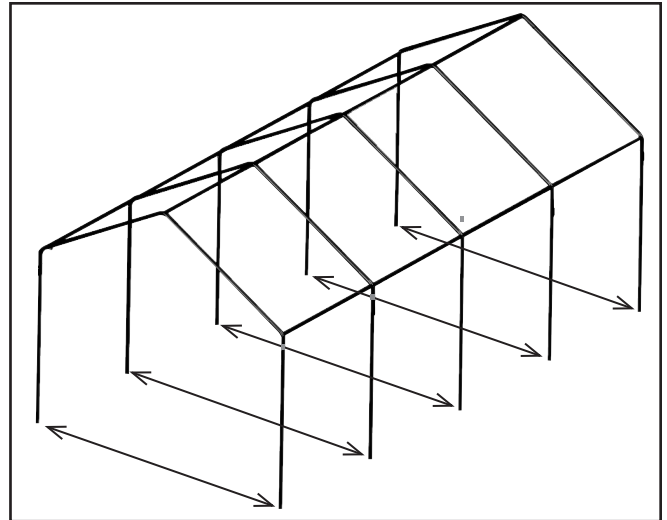

3. Examine the frame and remove any sharp edges from the frame or reposition screws (if equipped) so they do not come in contact with the roof cover.
4. After the frame is squared, read or reread the MUST READ document and anchor the shelter.

ANCHOR THE SHELTER

At this point, anchor the shelter. Consult the MUST READ document for anchoring information and suggestions. Please call customer service at 1-800-245-9881 for additional anchoring information.

CAUTION: The anchor assembly is an integral part of the shelter construction. Improper anchoring may cause shelter instability and failure of the structure to perform as designed. Failing to anchor the shelter properly will void the manufacturer's warranty and may cause serious injury and damage.

COMMERCIAL CANOPIES

OPTIONAL INSTALLATION - END and/or SIDE PANELS

If the shelter includes the optional side panels and/or end panels, these panels **MUST** be attached to the frame *before* the cover is installed. If the shelter does not include the optional panels, continue with the main cover installation.

NOTE: Optional gable ends and side panels (additional purchase required) are attached to the frame using ball tie downs in the manner illustrated below. If equipped, secure the panels to the frame before installing the main cover.

1. Unpack panels and unfold completely.
2. After anchoring the frame, place the ball tie downs through the grommet holes and loop around the lower end rafter legs.

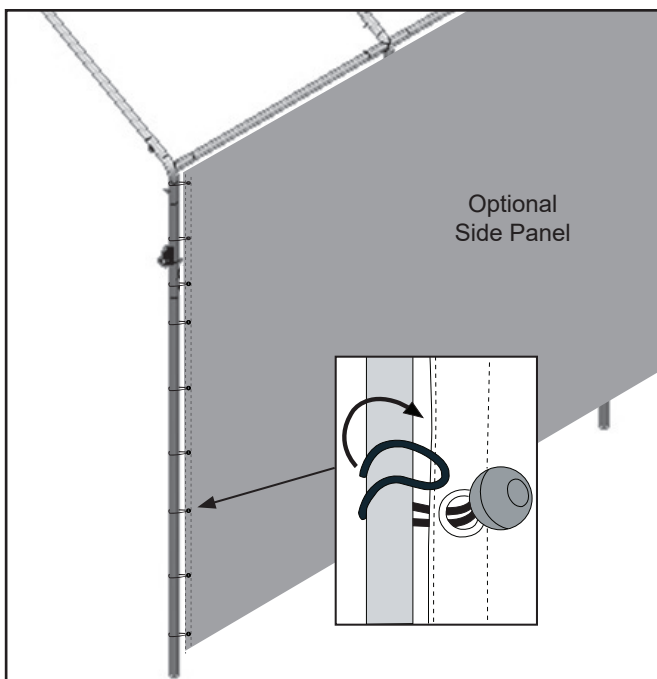

3. Install all side panels and/or end panels and continue with the main cover.

WARNING: Do not install panels without first anchoring the assembled frame.

INSTALL MAIN COVER

Gather the parts:

- Ratchets (1" 4000lb)
- Pipe 1.315" (See chart below.)
- Cover
- D-ring strap (#102947) & plain strap (#103620B)
- Ropes long enough to reach over the frame (supplied by customer)
- Tek screws and Fender washers
- Duct tape (supplied by customer)

WARNING: To prevent damage to the cover and to prevent serious personal injury, **DO NOT** attempt to install the cover on windy days.

1. Locate the pipes for two (2) main cover conduits. Each cover conduit consists of the following pipes. See chart below.

Cover Conduit Lengths	
Length	Pipes
20'	(3) 75" & (1) 25.5"
30'	(4) 75" & (1) 73.5"
40'	(6) 75" & (1) 49.5"
50'	(8) 75" & (1) 25.5"
60'	(9) 75" & (1) 73.5"

2. Connect these pipes by inserting the swaged ends of the pipes into the plain ends until each conduit is assembled. Secure each pipe joint with a Tek screw and wrap the joint with duct tape.

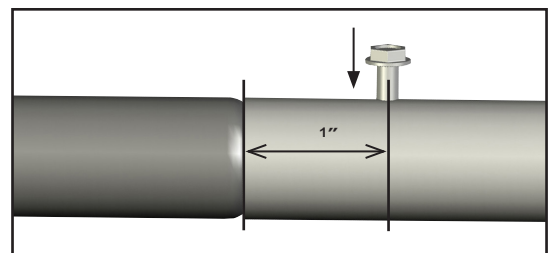

These cover conduits are inserted into the pockets sealed to the cover. The conduits are used to tighten and secure the cover.

3. After assembling the cover conduits, locate the cover and unfold it on a clean, smooth surface near the frame.

NOTE: When handling the cover and setting it in position, do not pull on the end straps. They will pull out of the cover. Unfold the cover with the inside surface facing up.

INSTALL COVER (CONTINUED)

4. Locate the cover ends with strapping and align cover with the front and back of the shelter.
5. Insert the cover conduits into the pockets of the cover.

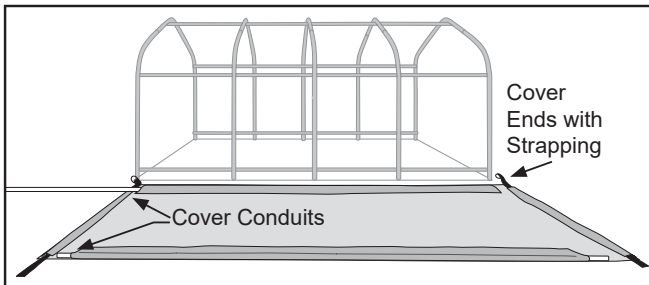

NOTE: Shelter shown above may differ in length from the actual model.

6. To pull the cover over the frame, attach ropes to both ends of the cover conduit. Wrap the rope around the conduit a few times to prevent it from slipping off.

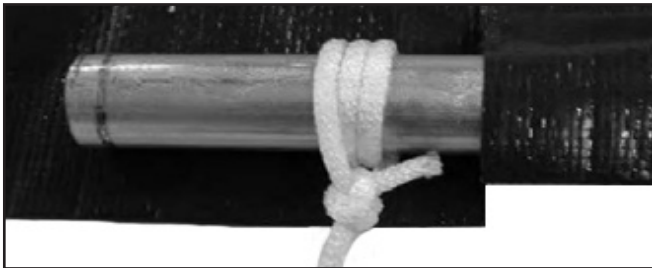

NOTE: Depending on the length of the cover it may be necessary to attach additional ropes to the cover conduit between the end ropes by cutting a small opening in the cover pocket and tying the rope around the conduit. *DO NOT* cut through the cover. *Cut through the conduit pocket only.*

7. With all ropes attached to the cover conduit, lift the conduit and carry the cover toward the base of the frame.
8. Toss the ropes over the frame and pull the cover into position. One person is required at each rope.
9. Center the cover end-to-end and side-to-side.

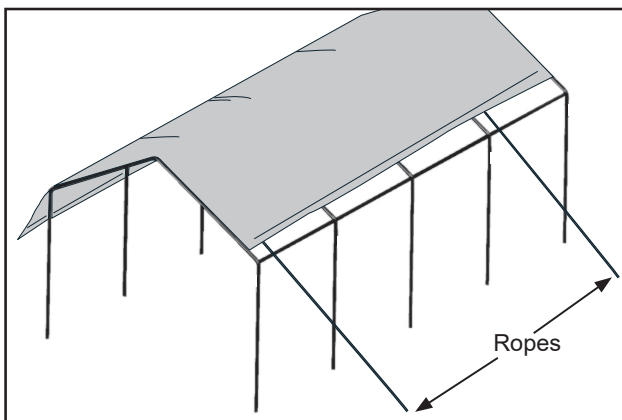

NOTE: Diagram shown without optional side or end panels.

10. At the ends, locate the black straps. Using the straps as guides, fasten ratchets to the outside of the end rafter legs using a Tek screw.

NOTE: Allow a few inches to remain between the end of the cover and the ratchet.

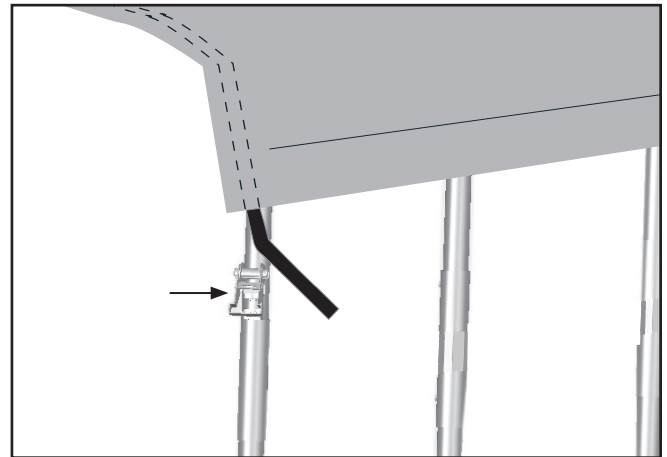

11. At the ends, thread the straps into the ratchets and slightly tighten. *Do not tighten completely at this time.*

NOTE: It may be necessary to remove excess strap if it binds up in the ratchet.

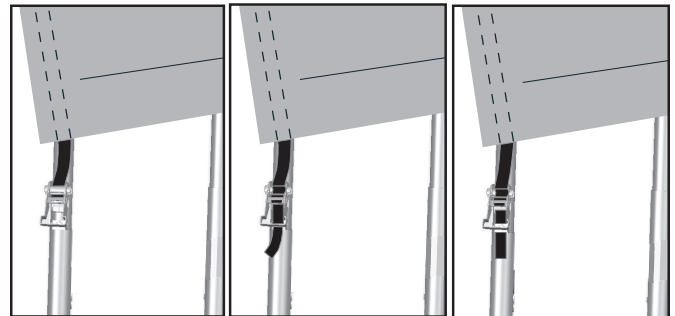

12. Place the D-ring straps on the ground along one side of the shelter next to the rafter where they will be attached. Place the plain straps and ratchets *on the opposite side of the shelter* at the same rafters as the D-ring straps.

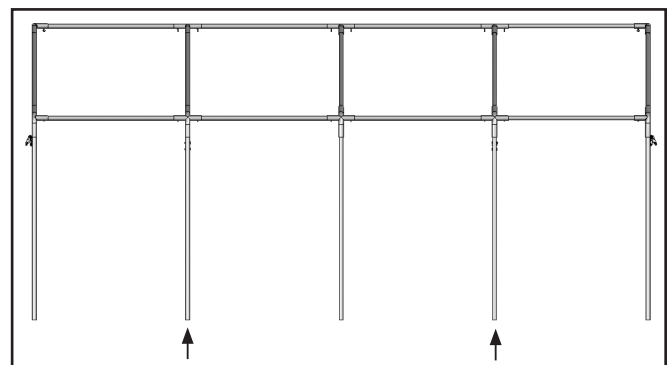

NOTE: Diagram above is an example of the 20' shelter.

COMMERCIAL CANOPIES

INSTALL COVER (CONTINUED)

13. On the side of the shelter where the D-ring straps are located, lift the main cover skirt (if present) and cut a slit through the main cover pocket in line with the rafter or rafters.

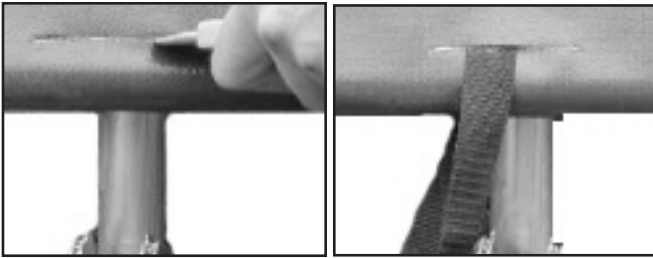

14. Thread the D-ring strap through the slit in the cover pocket, wrap it around the cover conduit, and attach the strap assembly to the rafter.

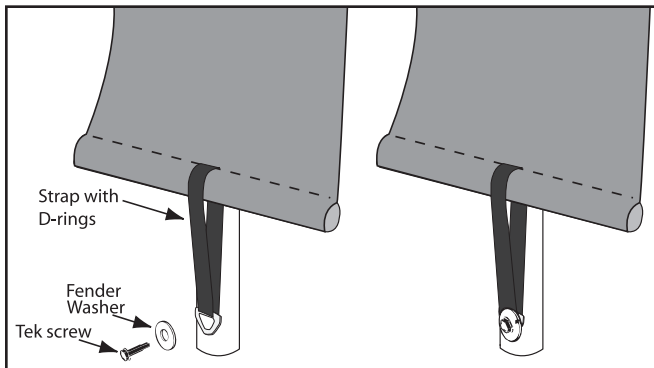

NOTE: Verify that the cover is centered side-to-side before attaching the D-ring straps. If optional side panels were attached, install the Tek screw through the panel.

15. Repeat the steps for the remaining D-ring straps.

NOTE: D-ring straps are attached to one side of the shelter. Ratchets are attached directly across from the D-ring straps on the *same rafter assembly*.

16. Move to the other side of the shelter and attach the ratchets to the rafters. Use the cover conduit and strap as guides to attach the ratchets to the rafters at the proper height. Fasten ratchets to the outside of these rafters using Tek screws.

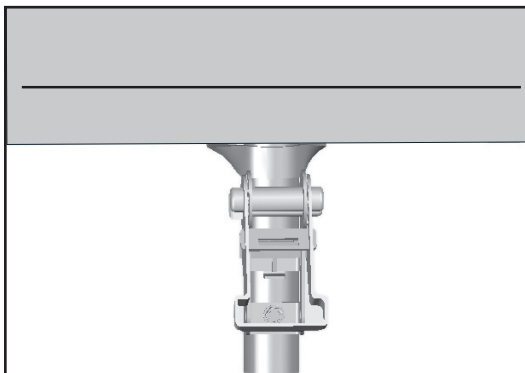

17. As previously described, make a slit in the cover conduit pocket and insert a 3' section of plain strap through the slit and around the cover conduit.

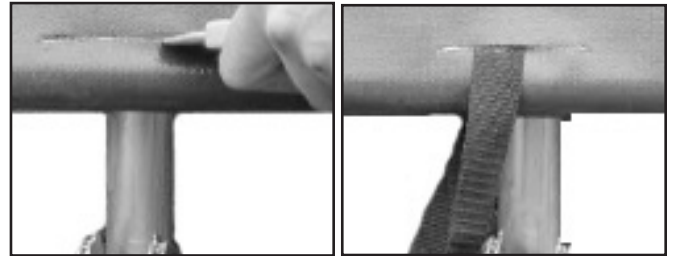

18. Thread the strap ends into a ratchet and slightly tighten.

NOTE: It may be necessary to remove excess strap if it binds up in the ratchet.

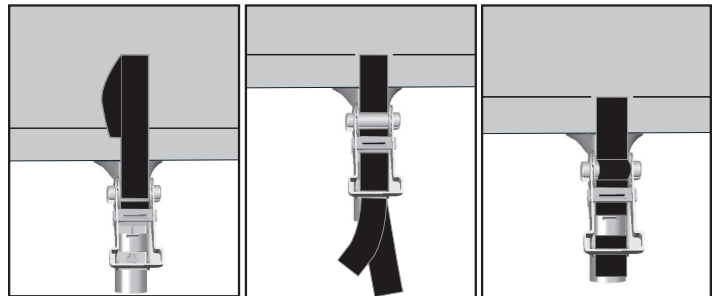

19. Repeat the steps for the remaining ratchet or ratchets.
20. Using additional help (if needed) tighten the main cover beginning with the ratchet or ratchets along the side of the shelter frame.
21. After the side ratchets are tightened, return to the end ratchets and tighten.

NOTE: Loosen the ratchets if needed to remove excess strap and tighten. If the main cover is not centered as desired, the D-ring straps can be repositioned (higher or lower) as needed and the main cover retightened.

22. Fold the skirt of main cover down and over the ratchets and D-ring straps to complete the installation of the main cover.

NOTE: Depending on the shelter, some main covers may not include a cover skirt.

SHELTER CARE AND MAINTENANCE

Proper care and maintenance of your shelter is important. Check the following items periodically to properly maintain your shelter:



Space below is reserved for customer notes.

- Regularly check the main cover and panels (if equipped) to see that these remain tight and in proper repair.
- Check connections and all fasteners to verify that they remain tight.
- Do not climb or stand on the shelter at anytime.
- Remove debris and objects that may accumulate on the shelter. Use tools that will not damage the cover when removing debris.
- Remove snow to prevent excess accumulation. Use tools that will not damage the cover when removing snow.
- Check the contents of the shelter to verify that nothing is touching the cover or the side panels that could cause damage.
- Check the anchoring system to ensure that all components are tight and in good repair.
- If the shelter is moved, inspect all parts and connections before reassembling.
- For replacement or missing parts, call 1-800-245-9881 for assistance.

NOTE: With the exception of Truss Arch buildings, FarmTek® shelters and greenhouses do not have any tested loading criteria.

FarmTek®

QUICK START GUIDE

18' Wide Commercial Canopies

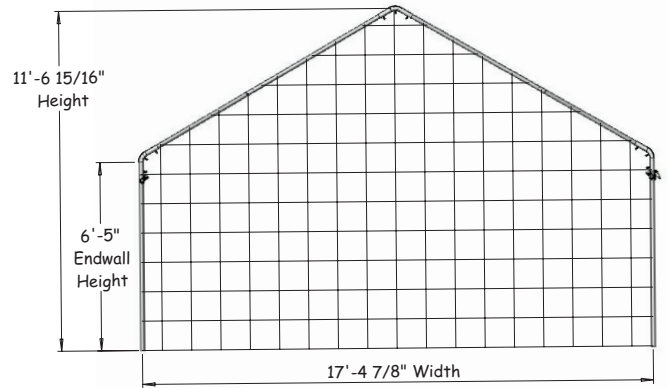

FRONT
Grid Represents 12" Squares

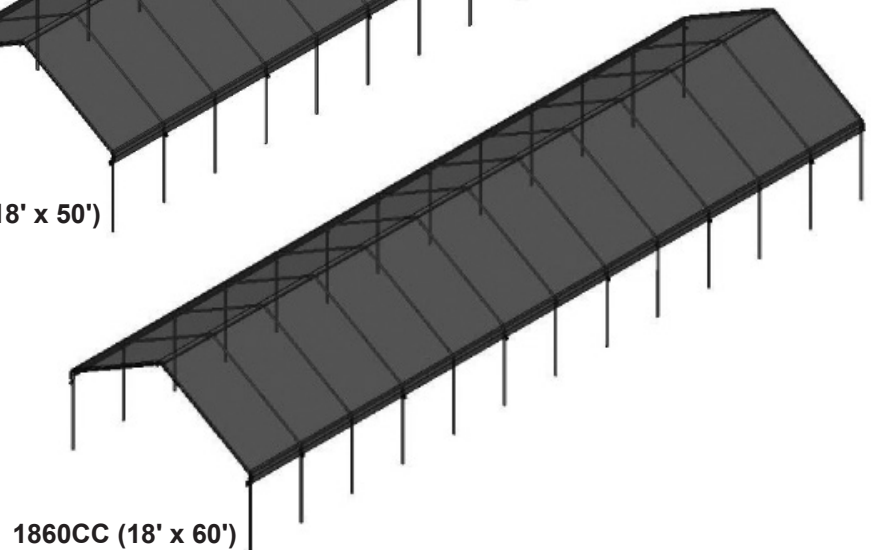
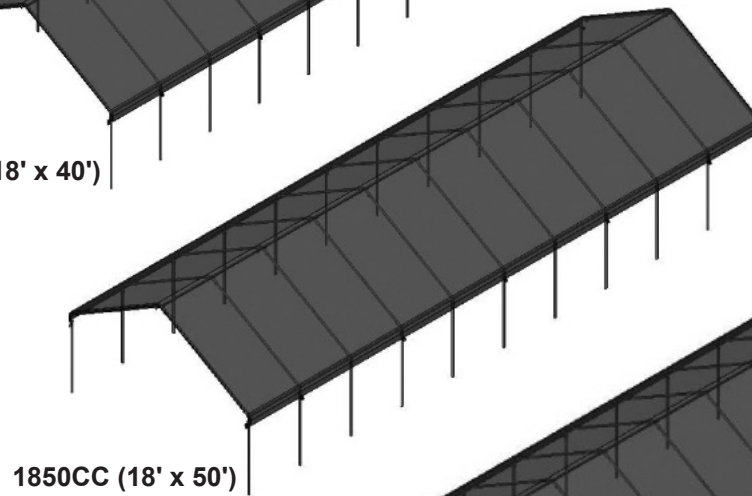
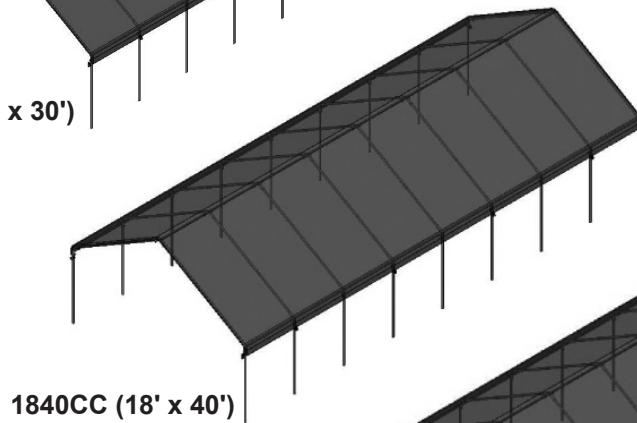
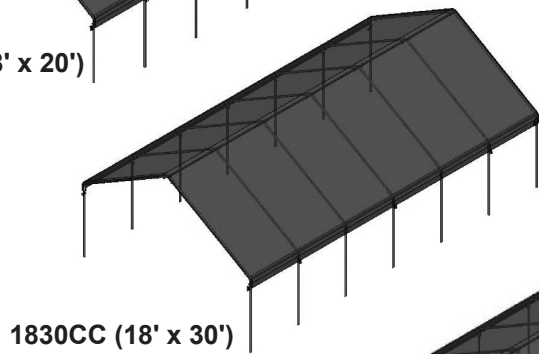
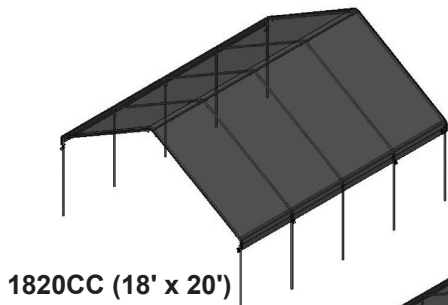

FRONT PROFILE

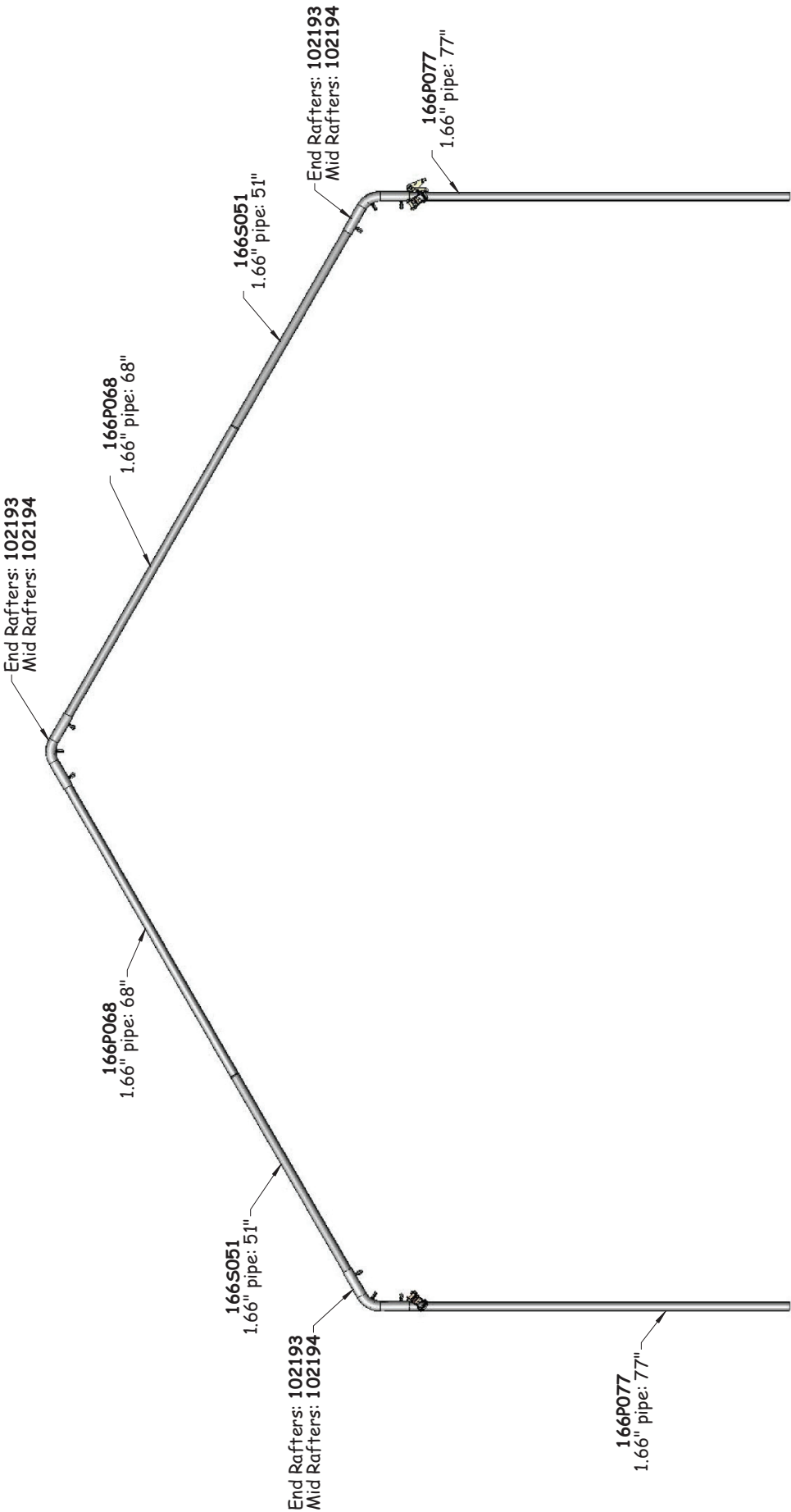

SIDE PROFILE - 1820CC

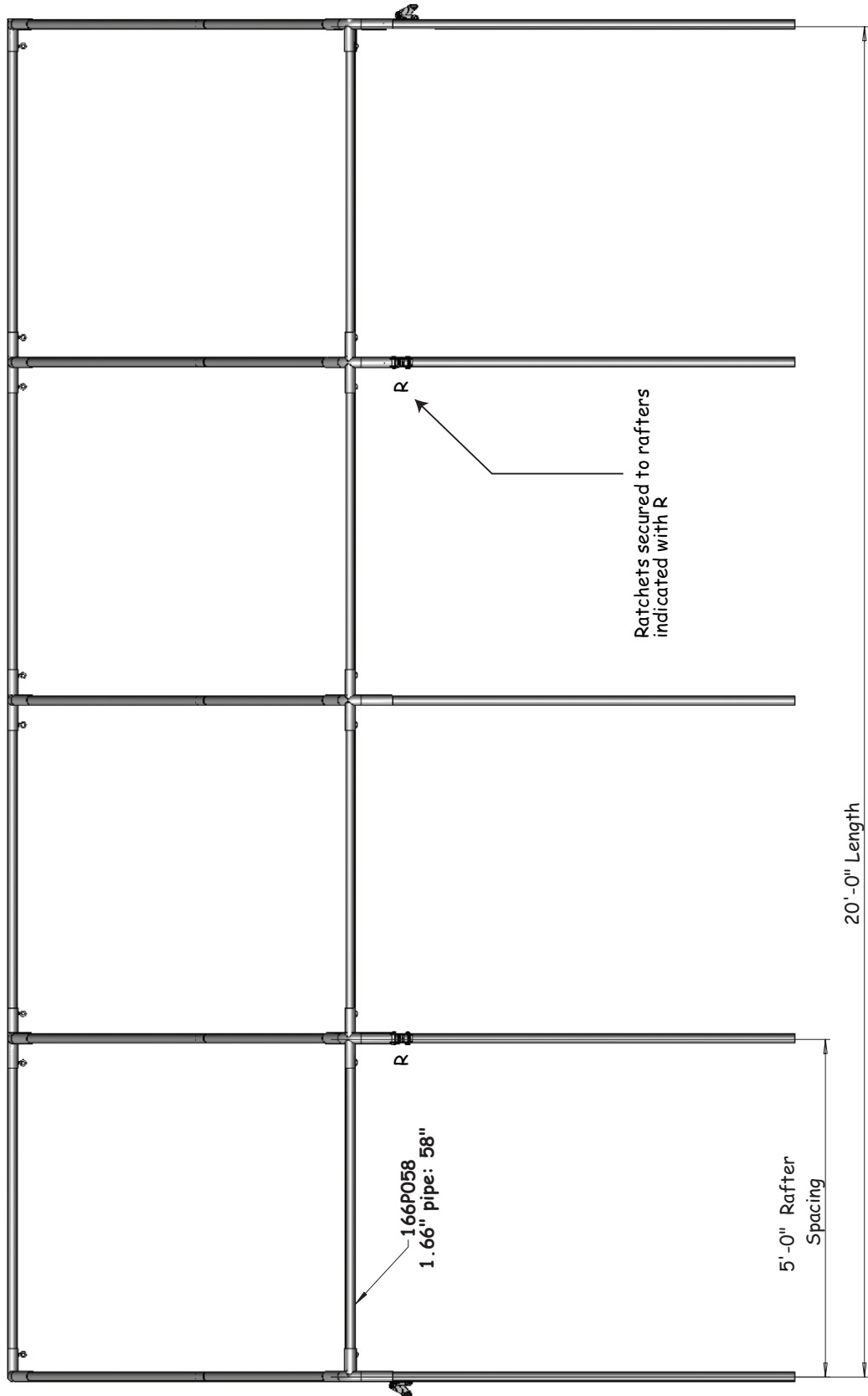

SIDE PROFILE - 1830CC

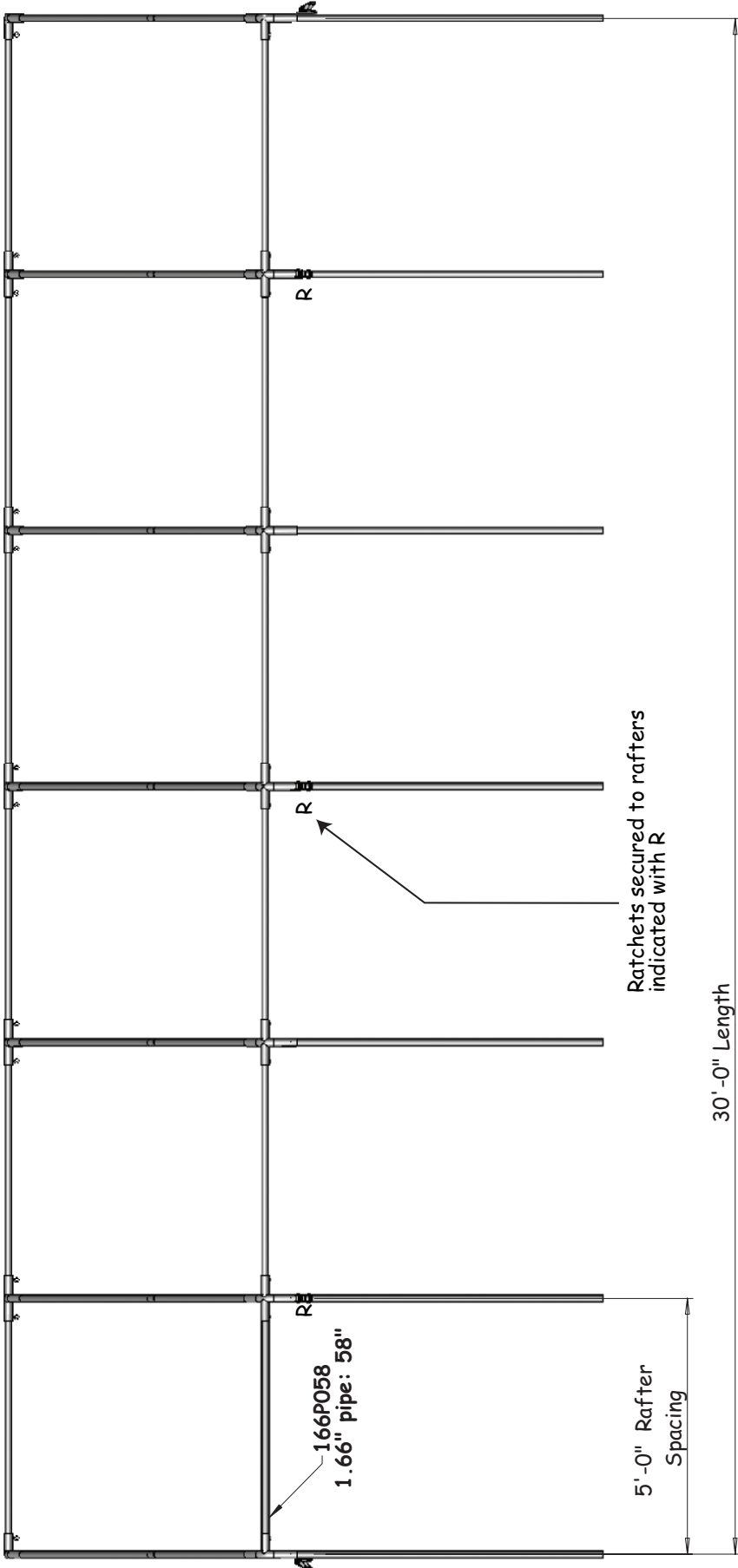

SIDE PROFILE - 1840CC

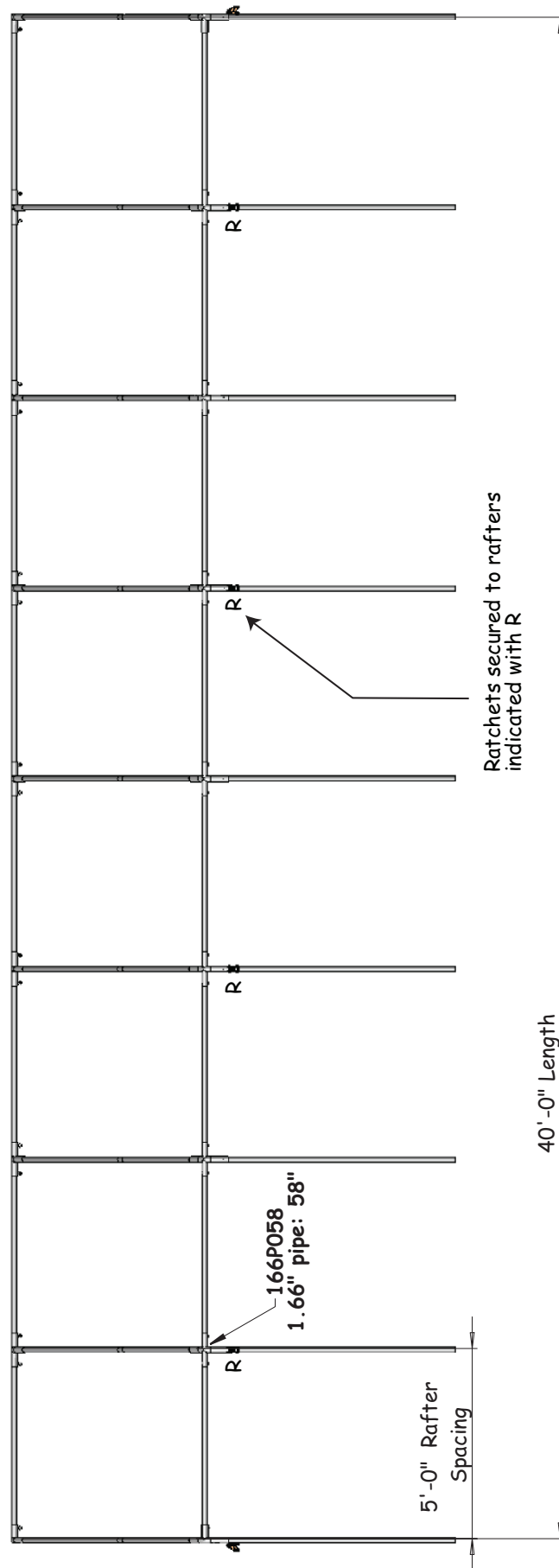

CONNECTIONS AND DETAILS

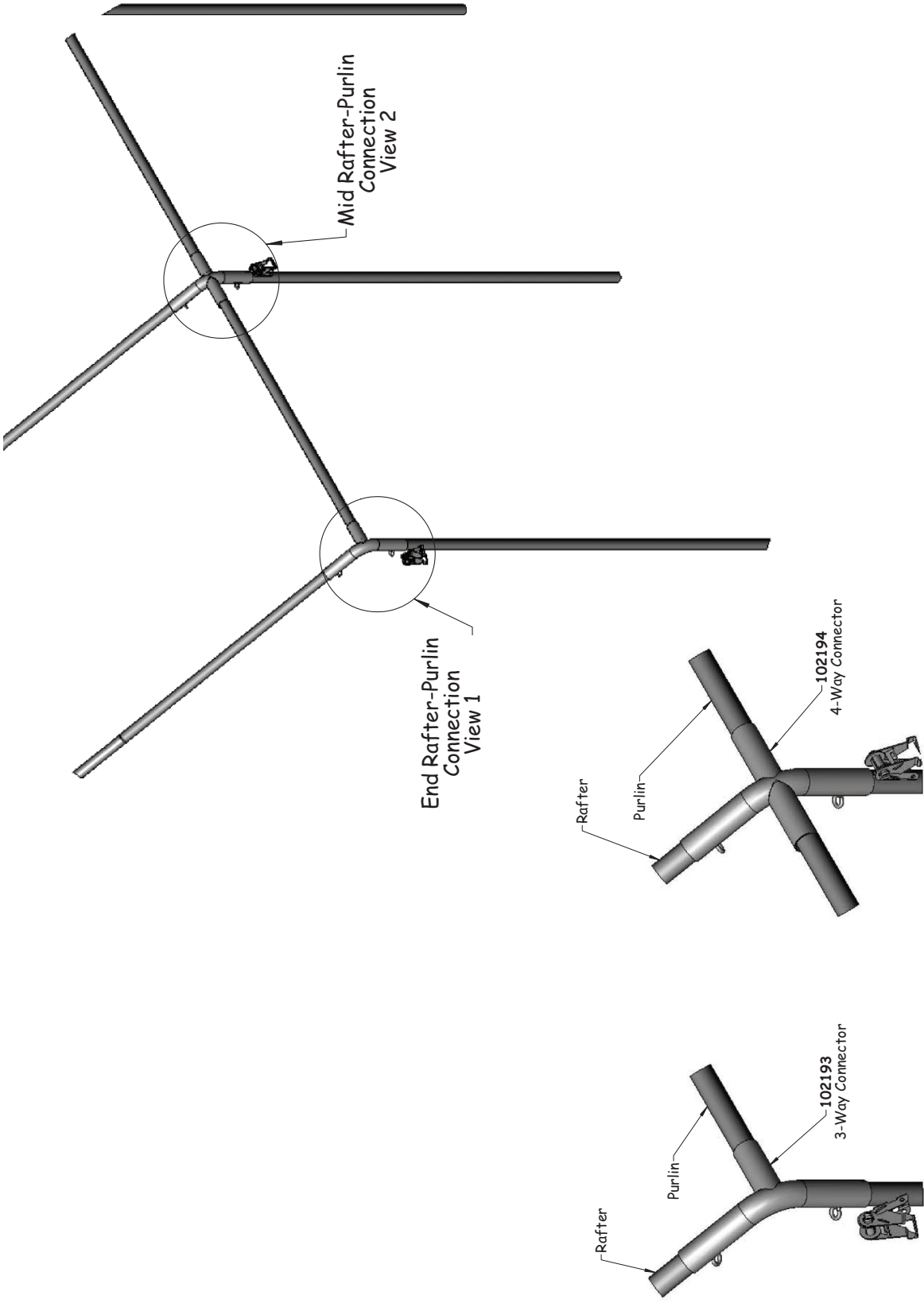

View 2
Mid Rafter-Purlin
Connection

View 1
End Rafter-Purlin
Connection